



English / Englisch

# Operating Instructions

Translation of original operating instructions  
for the three disc sanding machine

## TRIO

**Lägler**  
www.laegler.com

00.900.20.002 01.04.2015



---

# CONTENTS



---

<b>1</b>	<b>Introduction.....</b>	<b>5</b>
1.1	Features of the machine .....	5
1.2	Description of the machine .....	5
1.3	Intended use of the machine.....	6
1.4	Protective devices.....	6
1.5	Machine configuration.....	7
1.5.1	Basic equipment.....	7
1.5.2	Optional equipment.....	7
1.5.3	Wearing parts and safety-related parts .....	8
<b>2</b>	<b>Hazard warnings and safety instructions .....</b>	<b>9</b>
2.1	Hazard warnings.....	9
2.2	General safety instructions .....	14
<b>3</b>	<b>Technical data .....</b>	<b>16</b>
3.1	Data on type plate .....	16
3.2	Machine data .....	17
<b>4</b>	<b>Commissioning .....</b>	<b>19</b>
4.1	Preparing the machine.....	19
4.2	Connecting the power cable .....	22
4.3	Switching on the machine .....	23
4.4	Switching off the machine.....	25
<b>5</b>	<b>Working with the TRIO .....</b>	<b>26</b>
5.1	General information and tips.....	26
5.2	Changing the sanding plates.....	27
5.2.1	Removing the sanding plates.....	27
5.2.2	Mounting the sanding plates .....	28
5.3	Changing the sanding media .....	29
5.3.1	Changing the sanding discs .....	29
5.3.2	Conversion to sanding screens .....	30
5.3.3	Conversion to pads .....	30
5.4	Working with milling discs.....	31
5.5	Changing the dust bag .....	33
<b>6</b>	<b>Transport and storage.....</b>	<b>35</b>
6.1	Dismantling the machine before transportation .....	35
6.2	Reassembly after transportation .....	37
6.3	Storage .....	38
<b>7</b>	<b>Maintenance work and replacement of wearing parts .....</b>	<b>39</b>
7.1	Cleaning and care.....	40
7.2	Cleaning the filter cartridge .....	41
7.3	Changing the filter cartridge .....	42
7.3.1	Removing the filter cartridge .....	42
7.3.2	Mounting the filter cartridge.....	43
7.4	Changing the tooth belt.....	45
7.4.1	Removing the tooth belt.....	45
7.4.2	Mounting the tooth belt .....	46

## CONTENTS

7.5	Changing the V-belt.....	48
7.5.1	Removing the V-belt.....	48
7.5.2	Mounting the V-belt.....	50
7.6	Changing the sealing felt on the cover of the inner housing.....	52
7.7	Changing the rubber plugs of the sanding plate pulleys.....	53
<b>8</b>	<b>Regular inspection and maintenance work in accordance with accident prevention regulations .....</b>	<b>54</b>
<b>9</b>	<b>Causes of faults .....</b>	<b>56</b>
9.1	The machine does not run or has switched off automatically.....	56
9.2	The machine attempts to start up but is not able to do so.....	57
9.3	The machine runs but has no or very little sanding power capacity.....	58
9.4	The machine vibrates intensely and runs noisily.....	59
9.5	The machine runs but creates a great deal of dust.....	60
9.6	Sanding problems (waves, strips, grooves).....	61
<b>10</b>	<b>Circuit diagrams.....</b>	<b>64</b>
<b>11</b>	<b>Spare parts TRIO .....</b>	<b>66</b>
<b>12</b>	<b>Service passport .....</b>	<b>79</b>
<b>13</b>	<b>EU Declaration of conformity for machines (EU Directive 2006/42/EC).....</b>	<b>80</b>

### Safety notes used in this operating instructions and their meaning:

	<b><u>WARNING!</u></b>	<b>Death, severe physical injury or significant property damage</b> can occur if the corresponding cautionary measures are not taken!
	<b><u>CAUTION!</u></b>	<b>Moderate to light physical injury or property damage</b> can occur if the corresponding cautionary measures are not taken!
	<b><u>ATTENTION!</u></b>	An <b>undesired event</b> can occur if the corresponding instructions are not followed!

TRIO - MAIN COMPONENTS

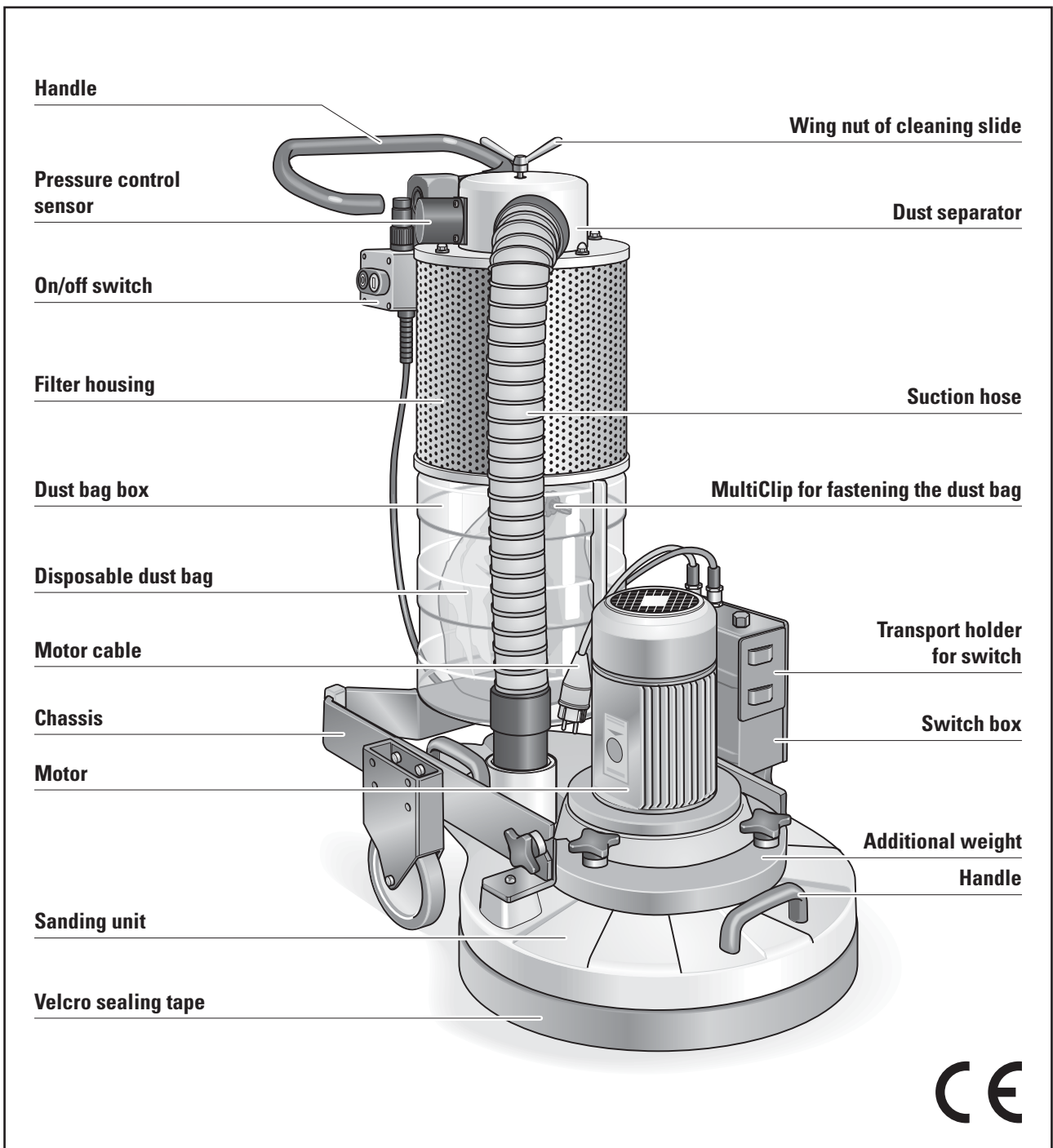

Fig. 1 Main components of the three disc sanding machine TRIO.

# Introduction

## 1.1 FEATURES OF THE MACHINE

*Figure 1* depicts the TRIO with the main components designated. Take your time to become familiar with the machine.

## 1.2 DESCRIPTION OF THE MACHINE

The TRIO works with three sanding discs that are suspended in a freely rotating support. The working area is fully covered by the machine housing.

The motor and switch box are positioned vertically on the machine housing. One of the cables leads to the power supply, the other to the on/off switch which can be positioned either on the switch box or below the guide handle.

The chassis consisting of the frame with guide tube, wheels and adjustable handle is mounted to the sanding unit with two cross grip fasteners and can be removed for transport purposes.

A dust separator is fixed to the chassis and connected to the dust suction system of the sanding unit by a flexible suction hose. Dust is separated by a coarse filter system and collected in the disposable dust bag.

Inside the dust bag box the dust bag is fastened to the dust separator with a MultiClip. The transparent dust bag box can be opened using two fasteners.

The air coming from the dust separator passes through a fine particle filter behind the perforated cover before being blown out into the environment. A sensor checks the air-pressure in the dust separator and a red warning lamp lights up when the suction capacity is too low.

To return to the correct suction capacity, the cleaning slide must be used to clean the fine particle filter.

**You have purchased a high-quality product from LÄGLER®. We wish you a great deal of success with your TRIO. All LÄGLER® products are subjected to a thorough inspection before leaving the factory.**

**Read these operating instructions completely before working with the TRIO for the first time! These operating instructions include important information on occupational safety and will provide you with answers to many questions so that you can work with the machine safely and without any problems. If you cannot find a specific subject in these operating instructions, please read the LÄGLER® application technique manual "Sanding of wooden floors" (<http://www.laegler.com>) or contact our service department, your retailer or your importer.**

**WARNING!****RISK OF DEATH from electrical shock:**

**The machine may never be used for wet processing operations of any kind!**

### 1.3 INTENDED USE OF THE MACHINE

---

The three disc sanding machine TRIO is suitable for dry sanding of wooden floors or cork floors in a dry environment. Additional milling discs are available for dry work on screed or other subfloors.

#### **Application fields**

- wooden floor finishing
- intermediate varnish sanding
- refurbishing of engineered flooring
- sanding of cork floors, screeds and fillers
- subfloor treatment
- removing of dirt, glue, carpet back and felt board residues
- application of cleaning agents, polish and cold wax
- dry polishing of surfaces

**Any other form of use is not permitted without the approval of the manufacturer!**

### 1.4 PROTECTIVE DEVICES

---

The following parts of the machine are protective devices and thus must always be kept in perfect condition:

machine housing	=	protection against tools and rotating parts
dust separator	=	protection of filter cartridge, protection against dust
dust bag box	=	dust bag protection
Velcro sealing tape	=	protection against dust
switch box	=	protection against current-carrying parts

## 1.5 MACHINE CONFIGURATION

### 1.5.1 BASIC EQUIPMENT

- 1 machine ready for operation
- 1 operating instructions
- 3 sanding plates for Velcro discs, sanding screen and pads
- 1 additional weight 9 kg (20 lbs)
- 25 dust bags
- 1 MultiClip for fastening the dust bag
- 1 extension cable, length 10 m (394"):
  - for single-phase AC motor 3 x 2.5 mm<sup>2</sup> (3 x 0.0039 sq.in.)
  - for three-phase AC motor 5 x 1.5 mm<sup>2</sup> (5 x 0.0023 sq.in.)
- 1 O-ring as a strain relief device
- 1 tool bag
- 1 Torx screwdriver T15
- 1 Torx screwdriver T30
- 1 closed mouth wrench, size 10/13 mm
- 2 open mouth wrench, size 17 mm
- 1 hexagonal socket wrench, size 4 mm
- 1 hexagonal socket wrench, size 5 mm
- 1 hexagonal socket wrench, size 6 mm
- 1 cotton bag
- 10 plastic pins
- 3 normal pads
- 3 sanding screens grit 60

### 1.5.2 OPTIONAL EQUIPMENT

- 3 milling discs with 3 indexable inserts each
- cable support bracket
- cable support with O-ring as a strain relief device
- foldable earmuff
- respiratory protection mask, filter class P3
- safety switch for fault current PRCD-S (for German mains supply)

#### NOTE:

You will find the corresponding part numbers for the optional equipment and wearing parts in *Section 11, Spare parts TRIO*.

### 1.5.3 WEARING PARTS AND SAFETY-RELATED PARTS

Check the condition of the wearing parts and safety-related parts mentioned below at regular intervals in order to be able to work safely and optimally at all times.

Replace the following parts in case of wear and/or damage:

- extension cable
- motor cable
- on/off switch
- Velcro sealing tape on machine housing
- MultiClip
- filter cartridge in dust separator
- pressure control sensor
- V-belt
- motor pulley
- V-belt tensioner
- tooth belt
- tooth belt tensioner
- rubber plugs of sanding plate pulleys
- sealing felt on cover of inner housing
- flexible Velcro ring of sanding plate
- wheels



# Hazard warnings and safety instructions

## 2.1 HAZARD WARNINGS



### **WARNING!**

#### **RISK OF DEATH from suffocation and RISK OF INJURY:**

- **Never** wrap the power cable around your neck or other parts of the body!

#### **RISK OF DEATH from electrical shock:**

- The machine may **never** be used for wet processing operations of any kind!
- Do not expose the machine to rain! Do not use the machine in moist or wet environments!
- **Never** connect the machine to hazardous electrical power sources! Only use safety sockets!
- To protect yourself and the machine against faults in the mains supply use a safety switch (for German mains supply part number in *Section 11, Spare parts TRIO*)!  
**Observe the applicable regulations and legal requirements in your country!**
- All extensive maintenance work, especially on the electrical equipment, **must** be conducted by a qualified expert for safety reasons!
- The machine **must** be switched off and the power plug **must** be removed from the socket during all maintenance work and work on the electrical equipment!
- Avoid body contact with grounded parts, e.g. pipes, radiators, ovens, refrigerators!
- The quality of the motor cable and the power cables **must** match the quality of the original LÄGLER® cables!
- The motor cable and the power cables must be protected from mechanical and electrical damages in the workplace!
- Do not carry or pull by the machine by the cable! Do not pull on the cable to remove the plug from the socket! Protect the cables against heat, oil and sharp edges!



### **WARNING!**

#### **RISK OF DEATH, RISK OF INJURY, RISK OF FIRE:**

- **Be certain to read the hazard warnings and safety instructions before using the machine!**
- **Instruct your coworkers and colleagues accordingly! Otherwise these persons could be exposed to danger or injured!**
- **Keep these hazard warnings and safety instructions in a safe place!**
- **Observe the applicable regulations and legal requirements in your country!**

**WARNING!****RISK OF DEATH from unsecured load:**

- When transported in a car or the like, the machines and all parts must be secured against sliding!

**RISK OF EXPLOSION due to sparks while sanding or a high dust concentration in the air:**

- Do not use the machine near
  - sources of fires,
  - flammable liquids or gases,
  - potentially explosive areas!
- Do not smoke in a dusty environment, e.g. while sanding, changing the dust bag or cleaning the machine!

**RISK OF FIRE from sparks while sanding or from spontaneous combustion:**

- Prior to sanding a nailed or screwed floor all nails or screws must be countersunk deeply enough so that they cannot be sanded:
  - Countersink the nails for example with a hammer and a punch!
  - Tighten the screws!
- There is a high risk of fire when sanding woods with a large amount of resin, oiled or waxed floors or metal! Therefore, the machine must **always** be cleaned carefully **directly** after sanding! **Be certain** to note the warning notices of the manufacturers of paint, oil and wax!
- Cloths, pads, et cetera which have been immersed in oil or wax can spontaneously combust! **Be certain** to note the warning notices of the manufacturers of paint, oil and wax!
- The dust bag must **always** be removed from the machine **directly** after sanding! Seal and dispose the dust bags in a **non-combustible** container! Cover this container with a **non-combustible** cover (→ *Section 5.5, Changing the dust bag*)!
- Always transport and store the machine **without** dust bag!

**WARNING!****RISK OF FIRE from the overheating of the cable.**

- Only the following motor cables and power cables may be used:
  - Machines with motor for mains voltage 220 V or 230 V:  
Cables with three wires and wire cross-sections of at least 2.5 mm<sup>2</sup> (0.0039 sq.in.)!
  - Machines with motor for mains voltage 400 V:  
Cables with five wires and wire cross-sections of at least 1.5 mm<sup>2</sup> (0.0023 sq.in.)!
- The maximum cable length in order to connect the machine to the mains supply must not exceed 20 m (790")!

**HEALTH RISK caused by dust:**

- Make sure that the dust bag is properly fastened to the machine!
- Note that each dust bag can only be used once!
- Do not use damaged or repaired dust bags! Damaged dust bags must be replaced with new ones!
- Do not work with an overfilled dust bag (➔ *Section 5.5, Changing the dust bag!*)
- Never work with the wing nut and cleaning slide of the dust separator pulled up, and observe the filter cleaning instructions to prevent clogging of the filter cartridge/dust separator. Clogging can otherwise make troublesome and time-consuming cleaning work necessary.
- If the machine is operated **correctly**, the mandatory dust emission values will not be exceeded! As long as you change the disposable dust bag with great care and according to the instructions printed on the dust bag, you are not required to wear a respiratory protective mask!
- A respiratory protective mask (at least filter class P2) must be worn when conducting other work that creates dust, e.g. cleaning of the machine!

**CAUTION!****RISK OF INJURY and RISK OF PROPERTY DAMAGE from rotating tools and parts of the machine:**

- For all operating conditions of the machine only one operator is required. As a consequence, for safety reasons only **one person** must be in the working area while operating the machine!
- Before switching on the machine, make sure that
  - all wrenches and adjustment tools have been removed from the machine,
  - the sanding plates or milling discs are in place correctly!
- The machine must not be switched on in a tilted position!
- **Never** leave the operational machine unattended!
- Do not reach into rotating tools or parts of the machine!
- Do not let children or other persons touch the machine or cables and keep them out of the work area!
- Do not wear any long articles of clothing or jewellery! These could be caught by moving parts!

**RISK OF INJURY and RISK OF PROPERTY DAMAGE from unintentional starting of the machine:**

- The power plug **must always** be removed from the socket when the machine is switched off!
- Make sure that on/off switch is not set to ON when connecting the machine to the mains supply!

**RISK OF INJURY and RISK OF PROPERTY DAMAGE from the rolling away, tipping or falling of the machine:**

- The machine must be secured against rolling away, tipping or falling when not in use!
- **Always** ensure that the machine is standing securely!

**RISK OF INJURY and RISK OF PROPERTY DAMAGE from unsuitable parts:**

- Only use tools, accessories and spare parts from LÄGLER® for the TRIO (part numbers in *Section 11, Spare parts TRIO*)! **Warranty claims for foreign parts or damage caused thereby cannot be accepted!**

**CAUTION!****HEALTH RISK caused by noise:**

- Use hearing protection when conducting work that produces noise! Observe the applicable regulations and legal requirements in your country!

**RISK OF PROPERTY DAMAGE:**

- Remove the sanding plates and milling discs from the machine when the machine is not to be used, because otherwise
  - the sanding media or milling discs can cause scratches on the ground,
  - the machine weight can damage the flexible Velcro rings of sanding plates or the indexable inserts of milling discs!
- Never conduct a maintenance or a replacement of wearing parts on the newly sanded wooden floor! Thus, you will avoid scratches or other damage to the floor!
- Never use any cleaning products which contain solvents!
- Never blow compressed air into the dust separator as otherwise the highly sensitive pressure control sensor could be damaged!
- Improper transport will result in damage to the machine!

## 2.2 GENERAL SAFETY INSTRUCTIONS

---

- **Check your machines for damage!**

Before using the machines, you must inspect the safety devices carefully to ensure that they are working perfectly and as intended.

Check whether the moving parts are working properly, that they are not sticking, that no parts are broken, whether all parts are in perfect condition and installed properly and whether all other conditions which could influence the operation of the machine are in order.

Damaged safety devices and parts must be properly repaired or replaced by an authorized service shop insofar as nothing to the contrary is indicated in the operating instructions.

Regularly inspect the motor cable and have it replaced by a qualified electrician if it is damaged. Inspect the extension cable regularly and replace it if it is damaged (part numbers in *Section 11, Spare parts TRIO*).

Damaged electrical components must be replaced by a qualified electrician (part numbers in *Section 11, Spare parts TRIO*).

Do not use the machine if it cannot be switched on and/or switched off by using its switch.

- **Maintain your machines with care!**

- Keep your machines clean so that you can work better and more safely.
- Follow the maintenance guidelines and the instructions for replacing tools.
- Keep the handles dry and free of oil and grease.

- **Provide good illumination in the workplace!**

Well lit construction sites reduce the risk of injury and allow you to better evaluate the quality of your work.

- **Keep your work area tidy!**

Untidy work areas create a risk of accidents.

- **Use the proper machines!**

Do not use low-performance machines or additional devices for heavy jobs. Do not use the machine for purposes and work that it is not intended for.

- **Do not overload the machines!**  
It works better and more safely in the power range noted.
- **Do not bend too far over the machine!**  
Avoid unnatural postures. Make sure that you stay in a stable position and keep your balance at all times.
- **Be attentive!**  
Pay attention to your work. Work carefully and do not use the machines if you are not concentrating.
- **Store your machines safely!**  
Store your unused machines in a dry, closed location out of the reach of children!

# Technical data

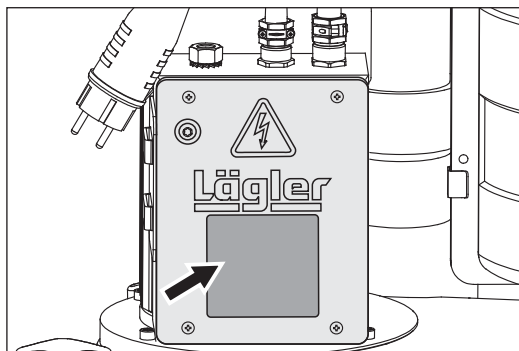

Fig. 2 Type plate on switch box of motor.

## 3.1 DATA ON TYPE PLATE

### **ATTENTION!**

**In order to receive the correct spare parts from us, please specify in inquiries and spare part orders always the serial numbers of your machines!**

The type plate is located on the switch box of motor (fig. 2). The following technical data are specified on the type plate (fig. 3):

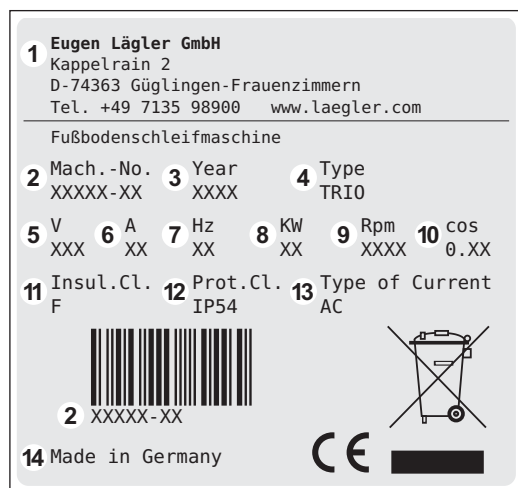

Fig. 3 Data on type plate.

- 1** Manufacturer
- 2** Serial number of machine (Mach.-No.)
- 3** Year of manufacture (Year)
- 4** Machine name (Type)
- 5** Required mains voltage in volt (V)
- 6** Current consumption in ampere (A)
- 7** Motor frequency in CPS (Hz)
- 8** Motor power in kilowatt (KW)
- 9** Motor speed in 1/min (Rpm)
- 10** Power factor cos phi (cos)
- 11** Insulation class (Insul. Cl.)
- 12** Protection class (Prot. Cl.)
- 13** Type of current
- 14** Country of manufacture



## 3.2 MACHINE DATA

Manufacturer	Eugen Lägler GmbH
Machine type	three disc sanding machine
Machine name	TRIO
Serial number	see type plate (fig. 2)
Year of manufacture	see type plate (fig. 2)

Motor type	single-phase AC motor		
Voltage	230 V	220 V	
Frequency	50 Hz (CPS)	60 Hz (CPS)	60 Hz (CPS)
Motor power	1.8 kW		
Running capacitor	40 µF		

Motor type	three-phase AC motor
Voltage	400 V
Frequency	50 Hz
Motor power	2.2 kW

Necessary fuse of mains supply	at least 16 A
Insulation class	F
Protection class	IP 54
Safety devices	no-voltage release, temperature switch as overload protection in the motor

Diameter of sanding plate / milling disc	200 mm (approx. 7.9")
Speed of sanding plate / milling disc	
- machine with motor 50 Hz (CPS)	approx. 600 1/min (rpm)
- machine with motor 60 Hz (CPS)	approx. 720 1/min (rpm)
Overall length of machine	870 mm (approx. 34.3")
Overall width of machine	490 mm (approx. 19.3")
Overall height of machine	990 mm (approx. 39")
Weight of sanding unit	54 kg (approx. 119 lbs)
Weight of chassis with dust separator	24 kg (approx. 53 lbs)
Overall weight of machine	78 kg (approx. 172 lbs)
Additional weight	9 kg (approx. 20 lbs)
Filter dimension	1.43 m <sup>2</sup> (approx. 15.4 sq. ft.)
Filter class	M

## TECHNICAL DATA

NOTE on noise emission:

The values indicated are emission values and must not represent safe workplace values as well.

Although a correlation exists between emission levels and immission levels, it is not always possible to determine whether additional precautionary measures are required.

Factors that can have an effect on the immission level existing at the workplace include the duration of the effects, the characteristics of the work area and other sources of noise, e.g. the number of machines and processing operations in the vicinity. The permissible workplace values may also vary from country to country.

This information, however, is intended to enable the user to better estimate the dangers and risks.

Running time after shut off	< 5 sec.
Dust emissions at workplace (measured as per the testing requirements GS-HO-15 of German Social Accident Insurance DGUV)	< 0.2 mg/m <sup>3</sup> (0.0024 gr./cu.yd.)
Workplace-related noise emission values, measurement taken 1.6 m (5.25 ft.) above floor	
- sanding of beech parquet with sanding disc grit 80	80 dB(A)
- removal of glue residue using milling discs	80 dB(A)
Measurement uncertainty constant of the noise emission values	4 dB(A)
Vibration total value $a_{hv}$ (measured at the handle)	< 2.5 m/s <sup>2</sup>

# Commissioning

This paragraph contains instructions on how to put your TRIO machine into operation at the workplace. In order to prevent damage and malfunctions it is necessary to strictly stick to the sequence of steps indicated below.



## CAUTION!

### **RISK OF INJURY and RISK OF PROPERTY DAMAGE:**

**Before working with the machine for the first time, operating staff must be adequately instructed!**

## 4.1 PREPARING THE MACHINE

### **ATTENTION!**

**To ensure safe dispatch of the machine, the packaging should be used for transport purposes!**

- 1 Unpack the machine carefully. Take care to deposit the packaging materials that are no longer required in an environmentally-friendly way.
- 2 After unpacking the machine, release the clamping lever of the handle (fig. 4, 1), press the handle forward (fig. 4, 2) and pull the clamping lever back into its prior position (fig. 4, 3).
- 3 While holding on to the handle, carefully tilt the machine backwards into a horizontal position (fig. 5). Make sure that the machine gets to rest on the guide tube (fig. 6, **A**) and the two protective rubbers (fig. 6, **B**). **Make sure the machine is in a safe position!** Now the sanding plates are accessible from the front.

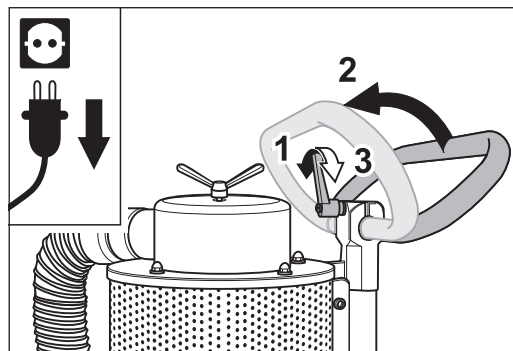

Fig. 4 To tilt the machine, release the clamping lever of the handle (1), press the handle forward (2) and pull the clamping lever back into its prior position (3).

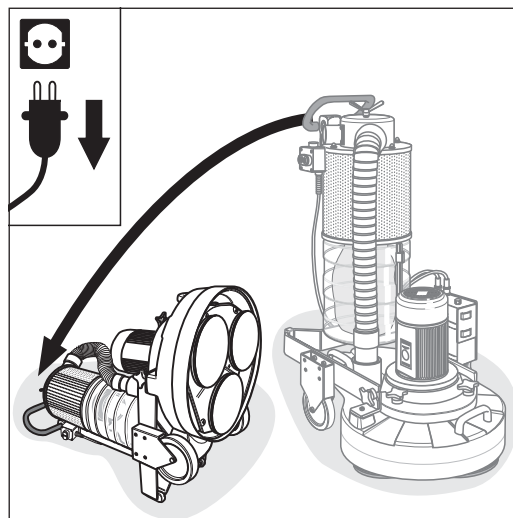

Fig. 5 Carefully tilt the machine backwards.

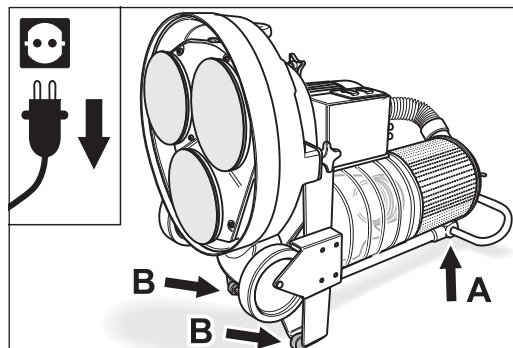

Fig. 6 Make sure that the machine gets to rest on the guide tube (**A**) and the two protective rubbers (**B**). **Make sure the machine is in a safe position!**

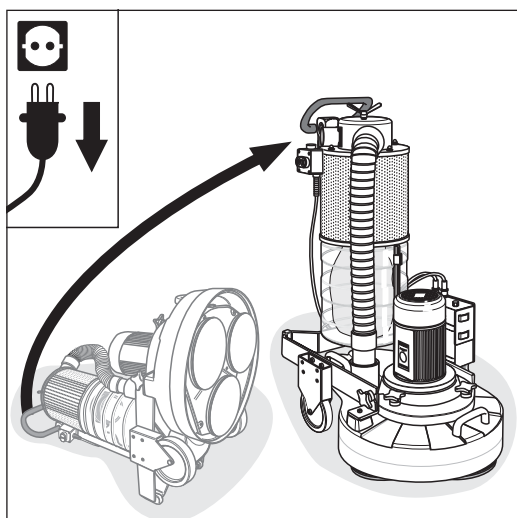

Fig. 7 Bring the machine back into vertical position.

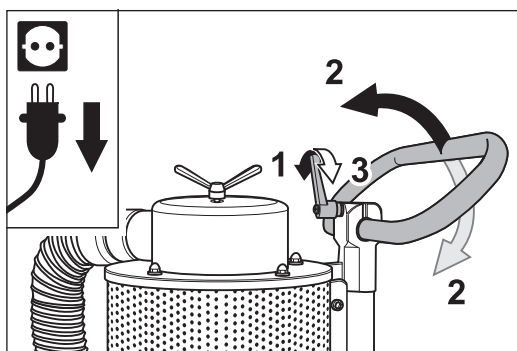

Fig. 8 Release the clamping lever of the handle (1), adjust the handle height to your convenience (2) and pull the clamping lever back into its prior position (3).

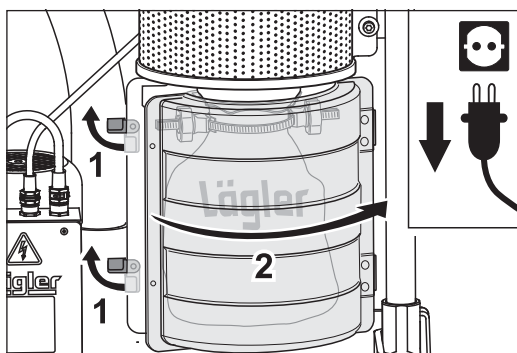

Fig. 9 Open the dust bag box by turning the two fasteners upwards (1) and open up the movable half of the dust bag box (2).

- 4 The changing of sanding media is described in:
- Section 5.3.1, Changing the sanding discs
  - Section 5.3.2, Conversion to sanding screens
  - Section 5.3.3, Conversion to pads

In order to work with milling discs please proceed as described in Section 5.4, Working with milling discs.



**CAUTION!**

**RISK OF INJURY and RISK OF PROPERTY DAMAGE:**

- **Make sure the sanding plates are in place correctly! They must fit tightly on the bearing and slide into place with a perceptible click!**
- **Always use three sanding plates of the same type!**

- 5 Bring the machine back into vertical position so that the sanding plates are resting flat on floor surface (fig. 7).
- 6 Release the clamping lever of the handle (fig. 8, 1), adjust the handle height to your convenience (fig. 8, 2) and pull the clamping lever back into its prior position (fig. 8, 3).
- 7 Open the dust bag box by turning the two fasteners upwards (fig. 9, 1) and open up the movable half of the dust bag box (fig. 9, 2).
- 8 Check to make sure the dust bag is placed correctly on the neck of dust separator (fig. 10, A). The side of the dust bag with the print on it must be facing you (fig. 10, B).

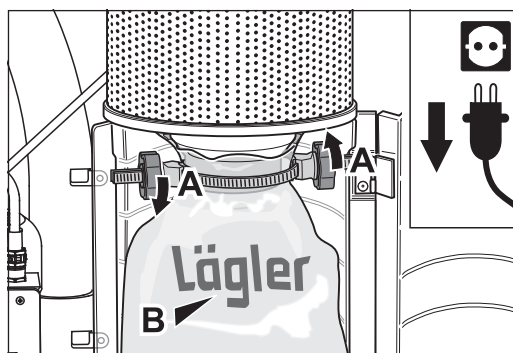

Fig. 10 Check to make sure the dust bag is placed correctly on the neck of dust separator (A). The side of the dust bag with the print on it must be facing you (B).

- 9 If there is no dust bag attached to the dust separator, proceed according to *Section 5.5, Changing the dust bag*.
- 10 Close the dust bag box (fig. 11, 1) and lock it by turning the two fasteners back to their downward position (fig. 11, 2).
- 11 Fix the Velcro sealing tape around the bottom edge of the machine housing in such a way that the two loose ends meet on the rear side (fig. 12). For optimum suction, there should be a gap approx. 1 mm wide between the lower edge of the sealing tape and the floor.

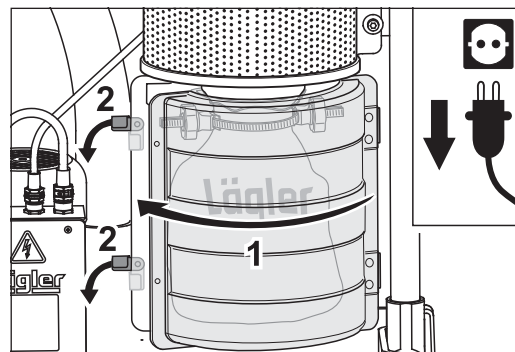

Fig. 11 Close the dust bag box (1) and lock it by turning the two fasteners back to their downward position (2).

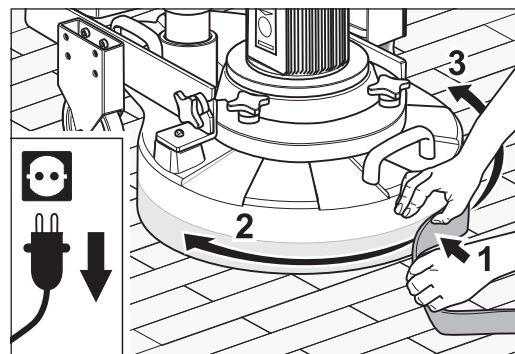

Fig. 12 Fix the Velcro sealing tape around the bottom edge of the machine housing.

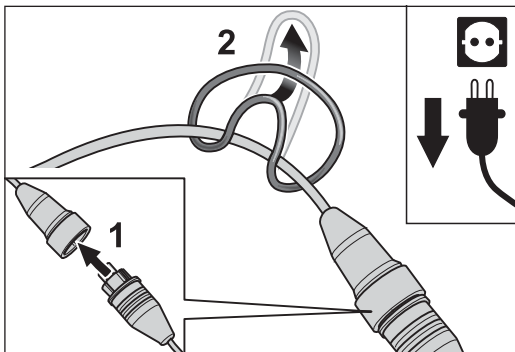

Fig. 13 Insert the plug of the motor cable in the coupler of the extension cable (1). Fasten the strain relief ring on the extension cable (2).

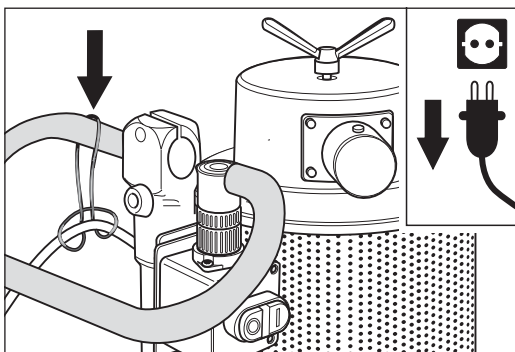

Fig. 14 Mount the strain relief ring on the handle.

## 4.2 CONNECTING THE POWER CABLE



### **WARNING!**

#### **RISK OF DEATH from electrical shock:**

- **Never connect the machine to hazardous electrical power sources! Only use safety sockets!**
- **To protect yourself and the machine against faults in the mains supply use a safety switch PRCD (for German mains supply part number in *Section 11, Spare parts TRIO!*)**
- **Observe the applicable regulations and legal requirements for your country!**

#### **RISK OF FIRE from the overheating of the cables:**

- **The maximum cable length in order to connect the machine to the mains supply must not exceed 20 m (790")!**
- **Only the following motor cables and power cables may be used:**
  - **Machines with motor for mains voltage 220 V or 230 V:**  
Cables with three wires and wire cross-sections of at least 2.5 mm<sup>2</sup> (0.0039 sq.in.)!
  - **Machines with motor for mains voltage 400 V:**  
Cables with five wires and wire cross-sections of at least 1.5 mm<sup>2</sup> (0.0023 sq.in.)!

- 1 Insert the plug of the motor cable in the coupler of the extension cable (fig. 13, 1).
- 2 Fasten the strain relief ring on the extension cable (fig. 13, 2).
- 3 Mount the strain relief ring on the handle (fig. 14).
- 4 Plug in the extension cable to a adequately fused mains socket with PE contacts.

## 4.3 SWITCHING ON THE MACHINE

**CAUTION!**

**RISK OF INJURY and RISK OF PROPERTY DAMAGE from rotating parts of the machine:**

- **Make sure the sanding plates or milling discs are in place correctly (→ Section 5.2, Changing the sanding plates)!**
- **The machine must not be switched on in a tilted position (fig. 15)!**
- **Never allow the machine to run unattended!**

**ATTENTION!**

**Before switching on the machine make sure that the cable plug of the sensor is inserted into the on/off switch (fig. 16 and → Section 6.2, Reassembly after transportation)! The machine will not start as long as this plug is disconnected!**

The machine can be switched on after these preparations have been completed. Before you do this, though, it is necessary to give the sanding plates or milling discs *a little leeway*. This is achieved by tilting the machine just slightly backwards using the black handle and switching on the machine by pushing the green button (I) on the on/off switch (fig. 17).

Please note that the sanding plates or milling discs should not completely lose contact with the floor when the machine is started up. On the other hand, if the machine is switched on without tilting it first, it will not run.

If after switching on the machine the red LED of the pressure control sensor lights up (fig. 18), check whether the dust bag is full (→ Section 5.5, Changing the dust bag) and the filter should be cleaned (→ Section 7.2, Cleaning the filter cartridge).

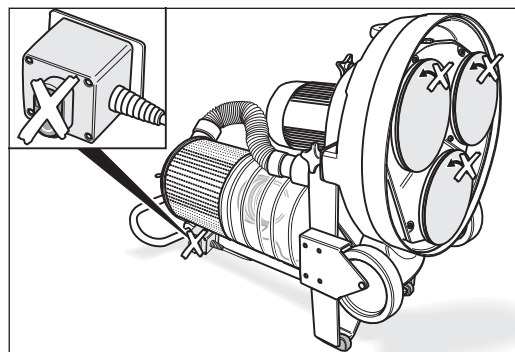

Fig. 15 The machine must not be switched on in a tilted position!

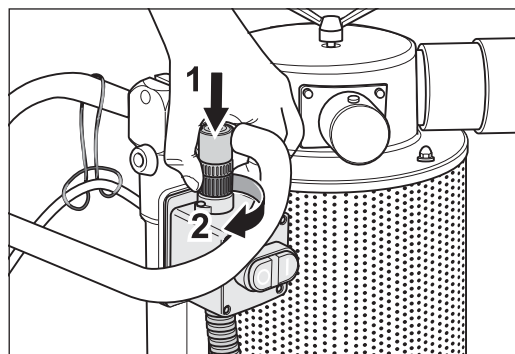

Fig. 16 Make sure that the cable plug of the sensor is inserted into the on/off switch!

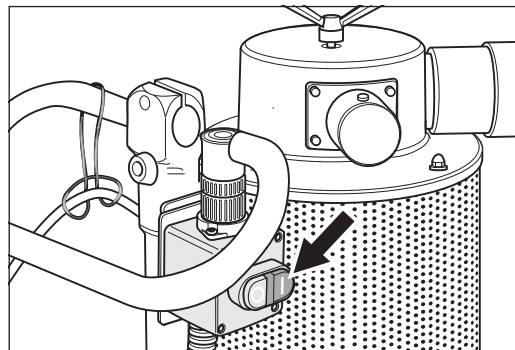

Fig. 17 To **switch** the machine **on**, push the **green** button (I) on the switch.

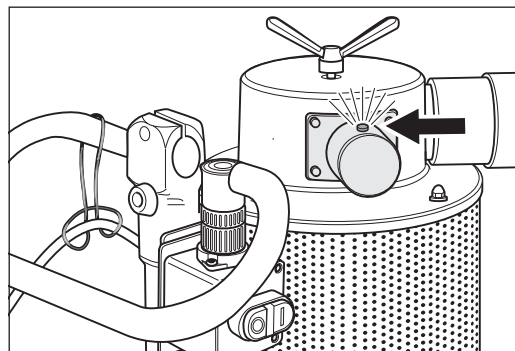

Fig. 18 If the red LED of the sensor lights up, check whether the dust bag is full and the filter should be cleaned!

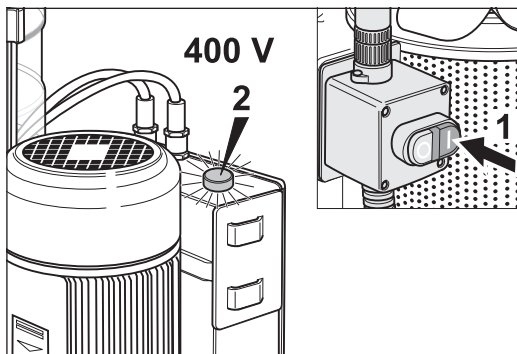

Fig. 19 The motor do not start by pushing the **green** button on the switch (1) and the light in the switch box shines (2).

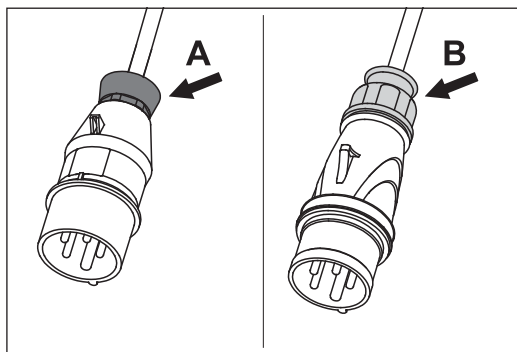

Fig. 20 Original LÄGLER® plug with **red** nut (A) or **yellow** nut (B).

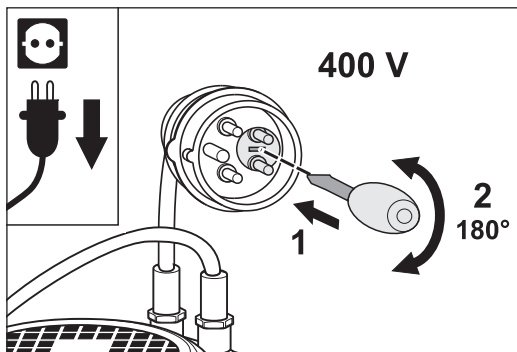

Fig. 21 Change the rotation direction of the motor by turning the phase changing switch at 180°.

#### MACHINES WITH THREE-PHASE AC MOTOR (MAINS VOLTAGE 400 V)

If the motor do not start by pushing the **green** button on the on/off switch (fig. 19, 1) and the light on the switch box shines (fig. 19, 2), the rotation direction of the motor is wrong.

To change the rotation direction of the motor using the following procedure:

- 1 **Disconnect the motor cable from extension cable!**
- 2 Original LÄGLER® plug with **red** nut at the cable outlet (fig. 20, A):
  - Put a screwdriver in the slit of the phase changing switch in the plug of the motor cable (fig. 21, 1).
  - To unlock the phase changing switch press the screwdriver in the slit and **at the same time** turn the screwdriver at 180° (fig. 21, 2).

Original LÄGLER® plug with **yellow** nut at the cable outlet (fig. 20, B):

- Put a screwdriver in the slit of the phase changing switch in the plug of the motor cable (fig. 21, 1).
- To unlock the phase changing switch turn the screwdriver at 180° against a small resistance (fig. 21, 2).

#### **ATTENTION!**

**The phase changing switch can only be turned in one direction!**



#### 4.4 SWITCHING OFF THE MACHINE

- 1 Tilt the machine just slightly backwards using the black handle.
- 2 Push the red button **(0)** on the on/off switch (fig. 22).
- 3 Keep hold of the machine until the sanding plates or milling discs comes to a complete standstill.

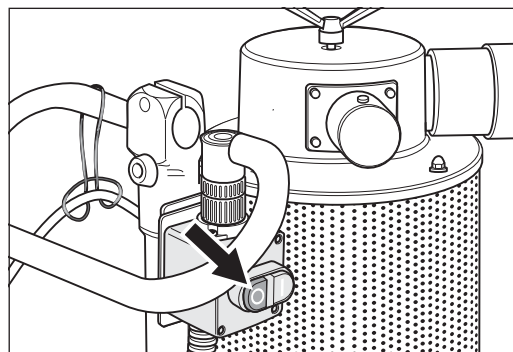

Fig. 22 To **switch** the machine **off**, push the **red** button **(0)** on the switch.



#### **CAUTION!**

##### **RISK OF INJURY and RISK OF PROPERTY DAMAGE:**

**Always remove the power plug from the socket after you have switched off the machine!**

##### **RISK OF PROPERTY DAMAGE:**

**Remove the sanding plates and milling discs from the machine when the machine is not to be used, because otherwise**

- **the sanding media or milling discs can cause scratches on the ground,**
- **the machine weight can damage the flexible Velcro rings of sanding plates or the indexable inserts of milling discs!**

# Working with the TRIO



## **WARNING!**

### **RISK OF DEATH from electrical shock:**

**The machine may never be used for wet processing operations of any kind!**

### **NOTE:**

For more information free of charge, please contact: within Germany

- Telephone: 0800 / 52 34 537

- Fax: 0800 / 48 66 353

within the USA

- Telephone: 800-848-6635

or

- Telephone: 0049 - 7135 - 98 90 - 0

- Fax: 0049 - 7135 - 98 90 - 98

- E-mail: [info@laegler.com](mailto:info@laegler.com)

- Internet: <http://www.laegler.com>

You will also find important and interesting application tips in the LÄGLER® application technique manual "Sanding of wooden floors" (<http://www.laegler.com>)!

## 5.1 GENERAL INFORMATION AND TIPS

**The ideal range of usage for the TRIO is fine sanding with grits starting at 60 and intermediate finish sanding!**

**The TRIO's functionality offers the following advantages:**

- As opposed to a belt sanding machine, a finer surface is achieved when using abrasives at the same grit.
- No particular sanding direction has to be followed (fig. 23).

For the first sanding of newly laid parquet it is advisable to use the HUMMEL® with sanding belts of up to grit 60 or grit 80, whatever the job demands. The choice of sanding medium depends on the kind of wood involved, initial run, type of sealing and the required surface finish.

With the TRIO, you should always begin with grit 60 sanding discs. In the case of a poor first run, the amount sanded off can be increased by sanding without the flexible Velcro rings. As with belt sanding, the first run has to eliminate all the signs of previous sanding jobs!

Sanding screens must be used for intermediate varnish sanding. The choice of grit depends on the varnish used, the varnishing speed and the required finish.

For cork floors, use grit 60 discs for your first run and grit 80 discs for the second. Intermediate varnish sanding and sanding of cork and rubber floors should be done without the additional weight.

Suction the dust from the floor thoroughly after each sanding process. Keep the wheels of the machine clean.

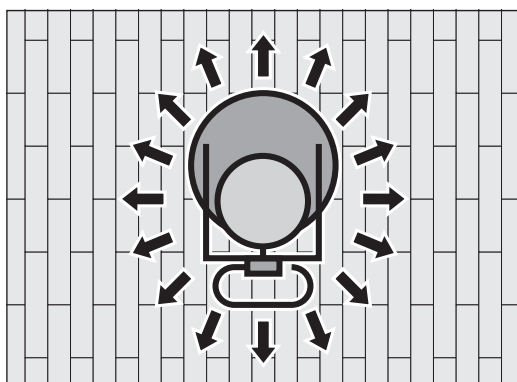

Fig. 23 Sanding directions using the TRIO.

## 5.2 CHANGING THE SANDING PLATES

Depending on the different types of work to be done you may have to change the sanding plates.

### 5.2.1 REMOVING THE SANDING PLATES

- 1 **Switch off the machine and pull the power plug out of the socket!**
- 2 Release the clamping lever of the handle (fig. 24, 1), press the handle forward (fig. 24, 2) and pull the clamping lever back into its prior position (fig. 24, 3).
- 3 While holding on to the handle, carefully tilt the machine backwards into a horizontal position (fig. 25). Make sure that the machine gets to rest on the guide tube (fig. 26, **A**) and the two protective rubbers (fig. 26, **B**). **Make sure the machine is in a safe position!** Now the sanding plates are accessible from the front.
- 4 To remove the sanding plate, grasp its edges with your fingers and pull it out of the rubber plugs of the bearing (fig. 27). **Never use a screwdriver or a chisel for this job as this could otherwise cause damage to the plates or the machine!**

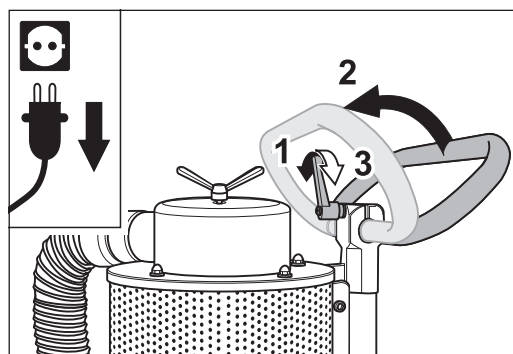

Fig. 24 To tilt the machine, release the clamping lever of the handle (1), press the handle forward (2) and pull the clamping lever back into its prior position (3).

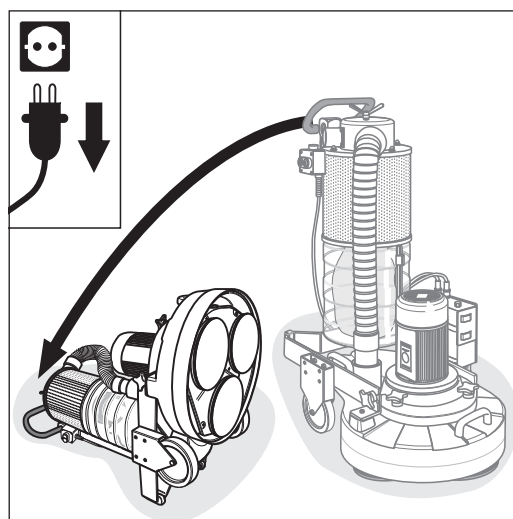

Fig. 25 Carefully tilt the machine backwards.

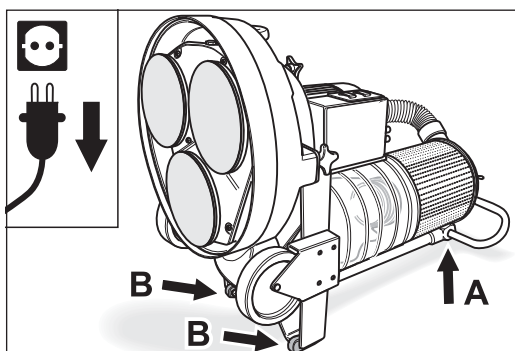

Fig. 26 Make sure that the machine gets to rest on the guide tube (**A**) and the two protective rubbers (**B**). **Make sure the machine is in a safe position!**

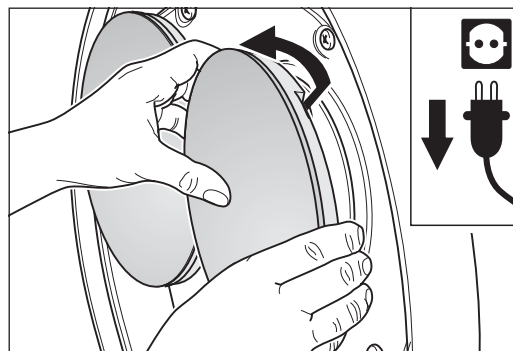

Fig. 27 Grasp the sanding plate edges with your fingers and pull it out of the rubber plugs.

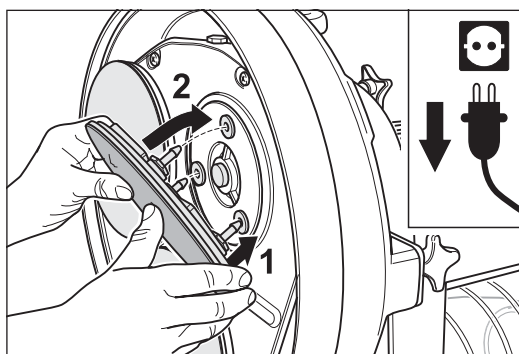

Fig. 28 Place one of the three bolts into the hole of one rubber plug (1), fit the others respectively (2) and press the sanding plate onto the bearing as far as it will go.

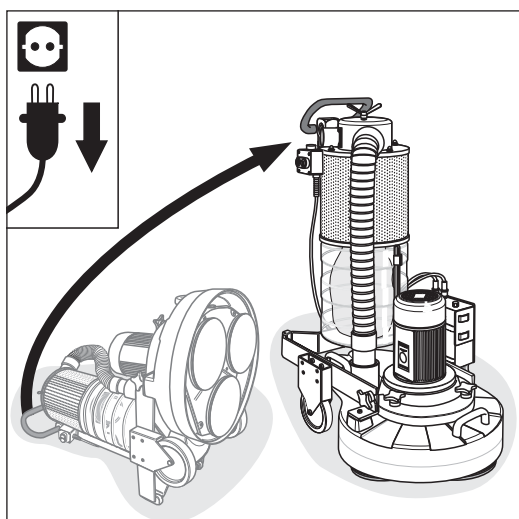

Fig. 29 Bring the machine back into vertical position.

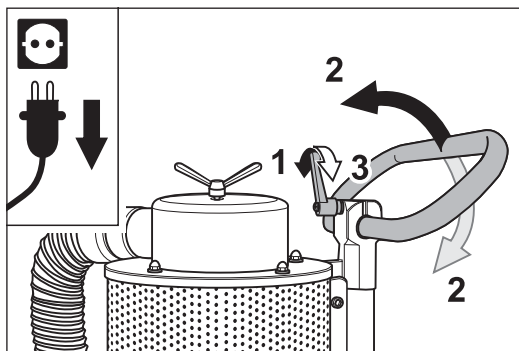

Fig. 30 Release the clamping lever of the handle (1), adjust the handle height to your convenience (2) and pull the clamping lever back into its prior position (3).

### 5.2.2 MOUNTING THE SANDING PLATES

- 1 Mount the sanding plate of your choice by placing one of the three locking bolts into the hole of one rubber plug (fig. 28, 1) and then fitting the other two bolts into their respective rubber plugs (fig. 28, 2). Then press the sanding plate onto the bearing as far as it will go.



#### **CAUTION!**

#### **RISK OF INJURY and RISK OF PROPERTY DAMAGE:**

- **Make sure the sanding plates are in place correctly! They must fit tightly on the bearing and slide into place with a perceptible click!**
  - **Always use three sanding plates of the same type!**
- 2 Bring the machine back into vertical position so that the sanding plates are resting flat on floor surface (fig. 29).
  - 3 Release the clamping lever of the handle (fig. 30, 1), adjust the handle height to your convenience (fig. 30, 2) and pull the clamping lever back into its prior position (fig. 30, 3).

## 5.3 CHANGING THE SANDING MEDIA

### 5.3.1 CHANGING THE SANDING DISCS

- 1 **Switch off the machine and pull the power plug out of the socket!**
- 2 Release the clamping lever of the handle (fig. 24, 1), press the handle forward (fig. 24, 2) and pull the clamping lever back into its prior position (fig. 24, 3).
- 3 While holding on to the handle, carefully tilt the machine backwards into a horizontal position (fig. 25). Make sure that the machine gets to rest on the guide tube (fig. 26, **A**) and the two protective rubbers (fig. 26, **B**). **Make sure the machine is in a safe position!** Now the sanding plates are accessible from the front.
- 4 To replace worn sanding discs, simply pull the sanding disc off the flexible Velcro ring (fig. 31).
- 5 Now place the new sanding disc in the centre of the flexible Velcro ring and press it in place. For increased sanding depth, place the sanding discs directly on the sanding plates (fig. 32, fig. 33).
- 6 Bring the machine back into vertical position so that the sanding plates are resting flat on floor surface (fig. 29).
- 7 Release the clamping lever of the handle (fig. 30, 1), adjust the handle height to your convenience (fig. 30, 2) and pull the clamping lever back into its prior position (fig. 30, 3).

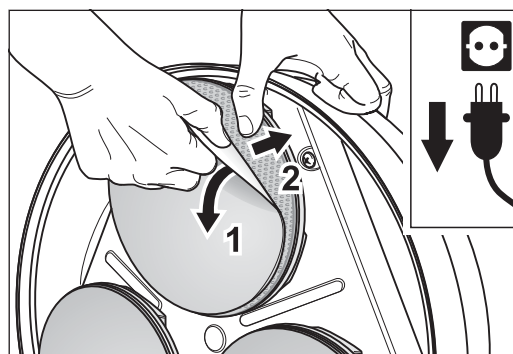

Fig. 31 Do not remove the flexible Velcro ring when removing worn-out sanding discs.

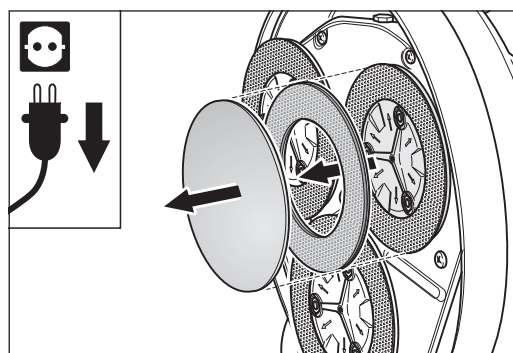

Fig. 32 Remove the sanding discs and the flexible Velcro rings.

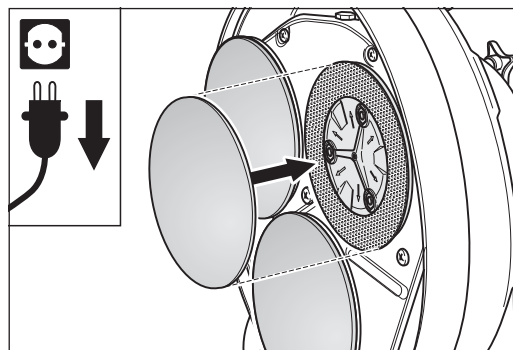

Fig. 33 Place the sanding discs directly on the sanding plates.

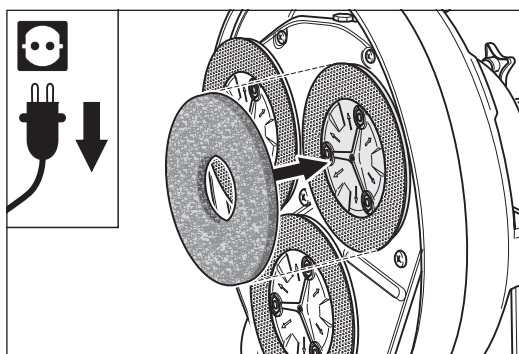

Fig. 34 Place the normal pads directly on the sanding plates.

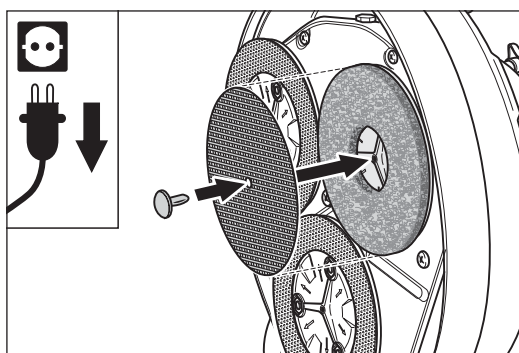

Fig. 35 The sanding screens are fixed quickly and securely to the pad base using the plastic plug.

### 5.3.2 CONVERSION TO SANDING SCREENS

- 1 **Switch off the machine and pull the power plug out of the socket!**
- 2 Release the clamping lever of the handle (fig. 24, 1), press the handle forward (fig. 24, 2) and pull the clamping lever back into its prior position (fig. 24, 3).
- 3 While holding on to the handle, carefully tilt the machine backwards into a horizontal position (fig. 25). Make sure that the machine gets to rest on the guide tube (fig. 26, **A**) and the two protective rubbers (fig. 26, **B**). **Make sure the machine is in a safe position!** Now the sanding plates are accessible from the front.
- 4 Remove the three sanding discs and flexible Velcro rings (fig. 32) and replace them by normal pads (fig. 34).
- 5 Place the sanding screen on the pad base. Insert the plastic plug through the sanding screen into the central hole in the sanding plate (fig. 35).  
To remove a sanding screen, grasp beneath it using both hands and pull this evenly off the sanding plate together with the plug.
- 6 Bring the machine back into vertical position so that the sanding plates are resting flat on floor surface (fig. 29).
- 7 Release the clamping lever of the handle (fig. 30, 1), adjust the handle height to your convenience (fig. 30, 2) and pull the clamping lever back into its prior position (fig. 30, 3).

### 5.3.3 CONVERSION TO PADS

- 1 **Switch off the machine and pull the power plug out of the socket!**
- 2 Release the clamping lever of the handle (fig. 24, 1), press the handle forward (fig. 24, 2) and pull the clamping lever back into its prior position (fig. 24, 3).
- 3 While holding on to the handle, carefully tilt the machine backwards into a horizontal position (fig. 25). Make sure that the machine gets to rest on the guide tube (fig. 26, **A**) and the two protective rubbers (fig. 26, **B**). **Make sure the machine is in a safe position!** Now the sanding plates are accessible from the front.

- 4 Remove the three sanding discs and flexible Velcro rings (fig. 32) and replace them by pads.
- 5 Fasten the pads with a plastic plug (fig. 36).  
To remove a pad, grasp beneath it using both hands and pull this evenly off the sanding plate together with the plug.
- 6 Bring the machine back into vertical position so that the sanding plates are resting flat on floor surface (fig. 29).
- 7 Release the clamping lever of the handle (fig. 30, 1), adjust the handle height to your convenience (fig. 30, 2) and pull the clamping lever back into its prior position (fig. 30, 3).

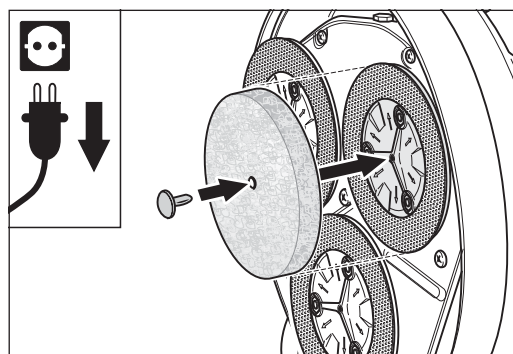

Fig. 36 The sanding pads are also fastened using the plastic plug.

## 5.4 WORKING WITH MILLING DISCS

The optional milling discs of the TRIO are used for subfloor treatments and processing. The milling discs are mounted in the same way as the sanding plates (→ *Section 5.2, Changing the sanding plates*).

### ATTENTION!

- **Make sure there is at least one indexable insert on every holder! Otherwise the holder will be destroyed!**
- **Make sure that the equipment of indexable inserts and holders is symmetrical!**

The milling discs are equipped with three or six holders for indexable inserts (fig. 37). The holders are equipped with one or two indexable inserts and a special screw to adjust cutting depth. Depending on the quality of the flooring can thus set the milling discs more or less aggressive accordingly (fig. 38, fig. 39).

To do this proceed as follows:

- 1 **Switch off the machine and pull the power plug out of the socket!**
- 2 Remove the milling discs from the machine (→ *Section 5.2.1, Removing the sanding plates*).

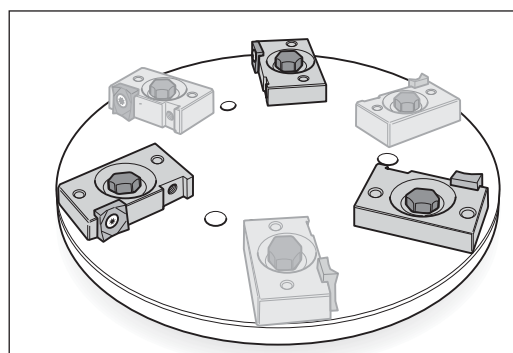

Fig. 37 You can use 3 or 6 holders on one milling disc. **Each holder has to have at least one indexable insert!**

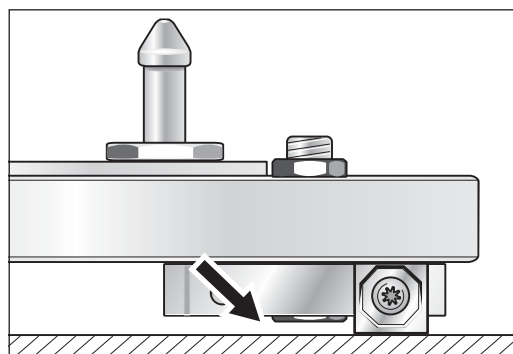

Fig. 38 **Aggressive** adjustment of the milling disc with special screw for working depth **turned in**.

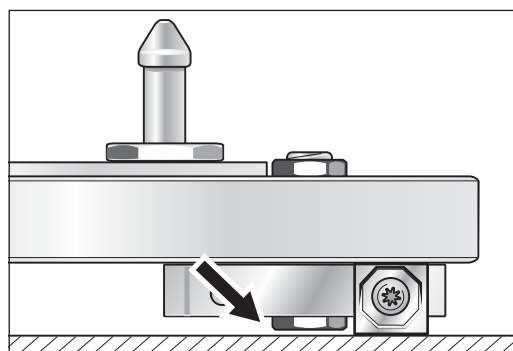

Fig. 39 **Less aggressive** adjustment of the milling disc with special screw for working depth **turned out**.

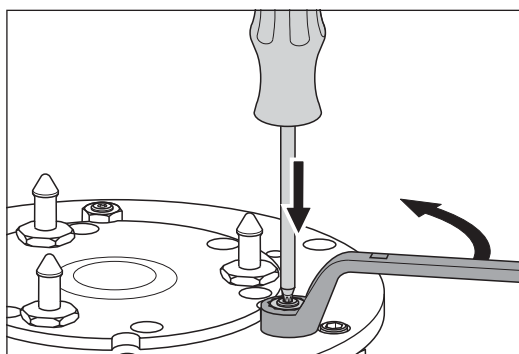

Fig. 40 Loosen the counter nut (wrench size 13 mm) for the holder to be adjusted.

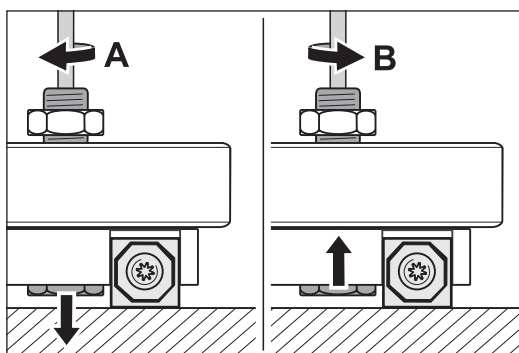

Fig. 41 Use the TORX screwdriver to adjust the adjustment screw.

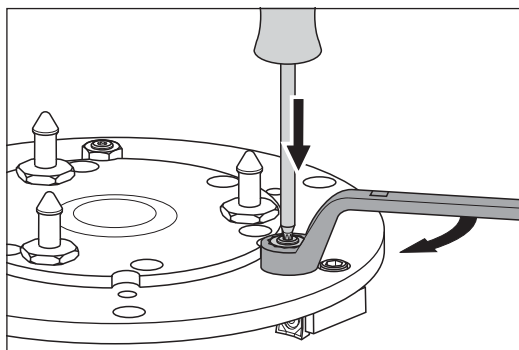

Fig. 42 Tighten the counter nut again.

- 3 Loosen the counter nut (wrench size 13 mm) on the top edge of the milling disc for the holder to be adjusted. Use the TORX screwdriver in the shaft of the thread to keep the adjustment screw in position (fig. 40).
- 4 Use the TORX screwdriver to adjust the adjustment screw. The indexable insert should be mounted in such a way that you can check the setting (fig. 41).
- 5 Tighten the counter nut again. Use the TORX screwdriver again to keep the adjustment screw in position (fig. 42).

**ATTENTION!**

**Make sure all screws are tight before you start working!**

- 6 Remount the milling discs as described in *Section 5.2.2, Mounting the sanding plates.*



## 5.5 CHANGING THE DUST BAG

**WARNING!****RISK OF FIRE from the formation of sparks while sanding:**

- **Note the warning on the dust separator (fig. 43)!**
- **The dust bag must always be removed from the machine directly after sanding (fig. 44, 1)!** Place the sealed dust bag in a non-combustible container!
- **Cover this container with a non-combustible cover (fig. 44, 2)!**

**HEALTH RISK caused by dust:**

In order to ensure that the dust values in the air do not exceed the prescribed threshold levels, please note:

- **Do not work with an overfilled dust bag!**
- **Note that each dust bag can only be used once!**
- **Damaged dust bags must be replaced with new ones!**

The disposable dust bag must be removed when it is full. Do not work with an overfilled dust bag, otherwise the dust emission in your working area will increase to a level that no longer fulfils the requirements for dust load at the workplace.

Make sure you use the original LÄGLER® dust bags only (part number in *Section 11, Spare parts TRIO*). **All other bags or sacks are inadequate!**

To change the dust bag proceed as follows:

- 1 Switch off the machine and pull the power plug out of the socket!**
- 2 Open the dust bag box by turning the two fasteners upwards (fig. 45, 1) and open up the movable half of the dust bag box (fig. 45, 2).**
- 3 Loosen the MultiClip by opening the nuts (fig. 46, 1).**
- 4 Carefully pull the full dust bag and the MultiClip from the neck of the dust separator (fig. 46, 2).**

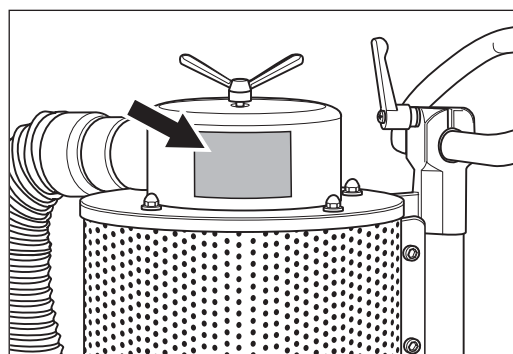

Fig. 43 Note the warning on the dust separator!

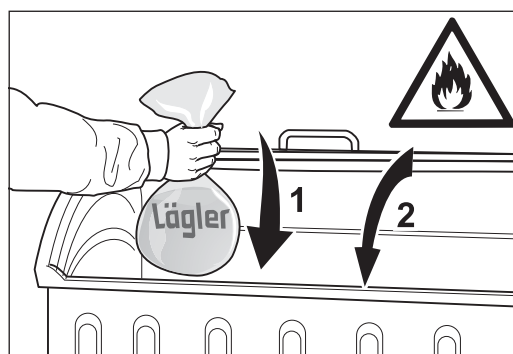

Fig. 44 Place the filled dust bag into a **non-combustible container** (1) and keep this closed (2) → **risk of fire!**

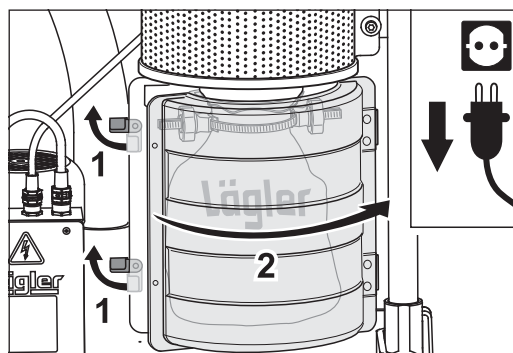

Fig. 45 Open the dust bag box by turning the two fasteners upwards (1) and open up the movable half of the dust bag box (2).

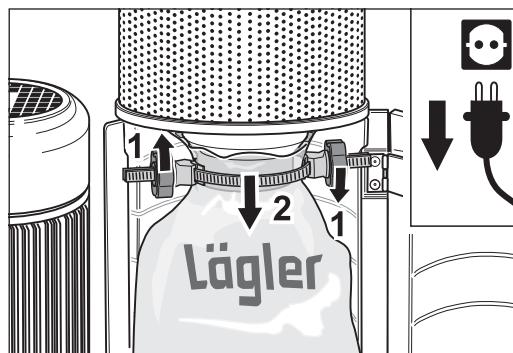

Fig. 46 Loosen the MultiClip by opening the nuts (1) and pull the dust bag and the MultiClip from the neck of the dust separator (2).

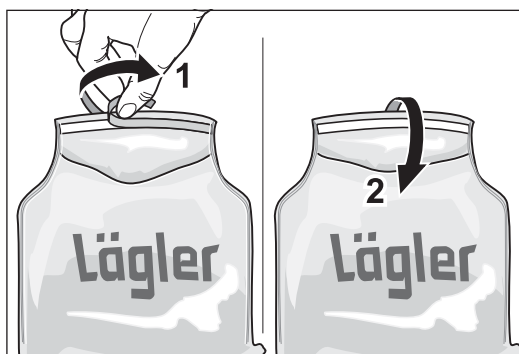

Fig. 47 Pull the cover foil from the adhesive strip (1) and seal the dust bag (2). **The dust bag must be deposited in a closed and non-combustible container!**

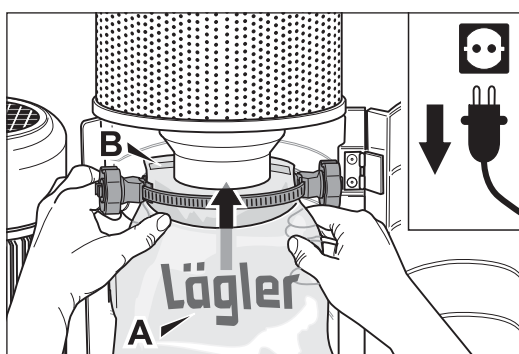

Fig. 48 **Make sure the dust bag is in the correct position:**  
 - print towards you (A),  
 - adhesive strip towards the rear (B)!

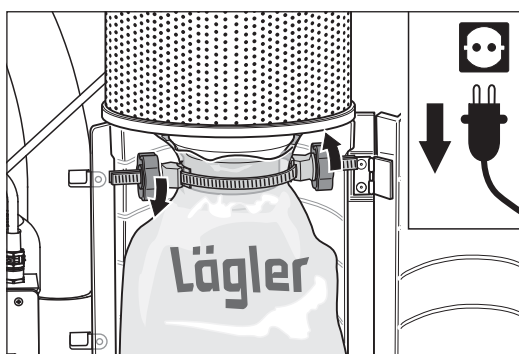

Fig. 49 Fasten the MultiClip by turning the nuts.

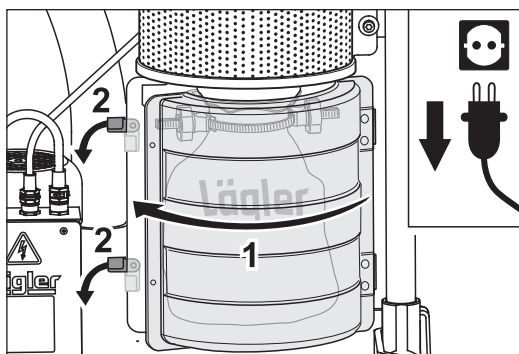

Fig. 50 Close the dust bag box (1) and lock it by turning the two fasteners back to their downward position (2).

- 5 Pull the cover foil from the adhesive strip on flap near the opening of the dust bag (fig. 47, 1).
- 6 Fold the flap over the opening of the dust bag and seal the bag (fig. 47, 2).

**ATTENTION!**

**Dust-free sealing of the dust bag is only possible when the dust bag has been mounted without any wrinkles on the neck of the dust separator!**

- 7 In order to preclude any damages by fire or explosion, throw the sealed dust bag in a non-combustible container (fig. 44, 1)! Cover this container with a non-combustible cover (fig. 44, 2)!
- 8 Slip the opening of new dust bag and the MultiClip over the neck of the dust separator. The side of the dust bag with the print on it must be facing you (fig. 48).
- 9 Fasten the MultiClip by turning the nuts (fig. 49).
- 10 Close the dust bag box (fig. 50, 1) and lock it by turning the two fasteners back to their downward position (fig. 50, 2).
- 11 Clean the filter cartridge of the dust separator as described in Section 7.2, *Cleaning the filter cartridge*.

# Transport and storage



## **WARNING!**

### **RISK OF INJURY and RISK OF PROPERTY DAMAGE:**

**When transported in a car or the like, the machines and all parts must be secured against sliding!**

### **RISK OF FIRE from formation of sparks while sanding:**

**Always transport and store the machine without dust bag!**

### **RISK OF FIRE from spontaneous combustion:**

**Oil or wax can lead to spontaneous combustion! Therefore, the machine must always be cleaned carefully before transport or storage!**

## 6.1 DISMANTLING THE MACHINE BEFORE TRANSPORTATION

For transport purposes the machine can be dismantled into two pieces: chassis (frame with wheels, guide tube and dust separator) and sanding unit (machine housing with motor and sanding disc gear).

The TRIO three disc sanding machine is dismantled as follows, please stick precisely to the suggested sequence of steps:

- 1 Switch off the machine and pull the power plug out of the socket!**
- 2 Loosen the cable plug of the sensor on the on/off switch by turning the ring nut **counterclockwise** (fig. 51, 1) and pull the cable plug off (fig. 51, 2).**
- 3 Remove the on/off switch from the chassis (fig. 52, 1) and hook it into the transport holder on motor switch box (fig. 52, 2).**

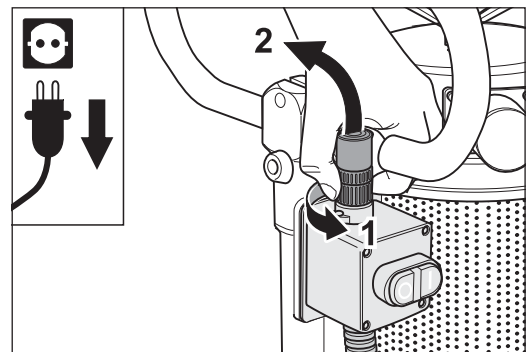

Fig. 51 Loosen the ring nut (1) and remove the cable plug from the switch (2).

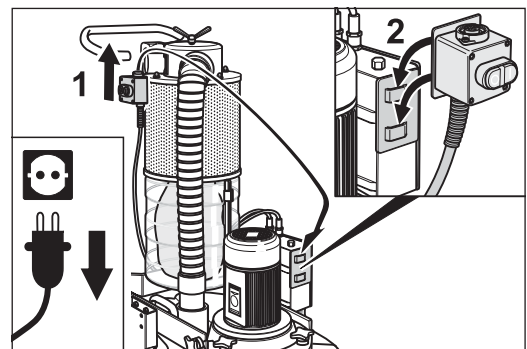

Fig. 52 Hook the on/off switch into the transport holder on motor switch box.

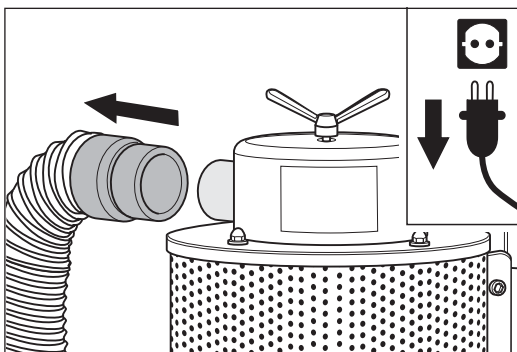

Fig. 53 Pull the suction hose from the neck of the upper part of the separator.

- 4 Pull the suction hose from the neck of the upper part of the separator (fig. 53).
- 5 Loosen the two cross grip fasteners at the side by which chassis is attached to machine housing (fig. 54, 1) and move the chassis backwards (fig. 54, 2).

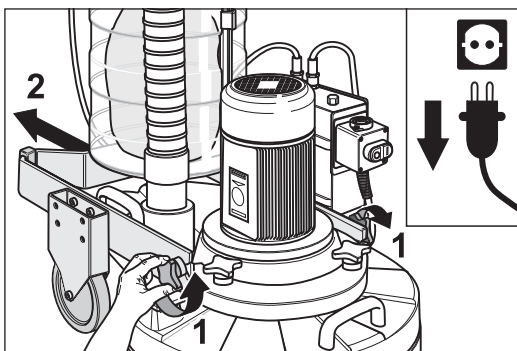

Fig. 54 The chassis can be moved backwards once the cross grip fasteners have been loosened.

## 6.2 REASSEMBLY AFTER TRANSPORTATION

When reassembling the TRIO after transporting it please proceed according to the following sequence:

- 1 Roll chassis into attachment position so that the two fasteners can be homed in (fig. 55, 1).
- 2 Tighten the two cross grip fasteners firmly (fig. 55, 2).
- 3 Remove the on/off switch from motor switch box and hook it into holder on the chassis (fig. 56).
- 4 Insert the cable plug of the sensor into the on/off switch. **Make sure the nose of the cable plug is inserted in the groove of the socket (fig. 57)!** Lock this connection by turning the ring nut **clockwise** (fig. 58).

### **ATTENTION!**

**The machine will not start as long as the cable plug of the sensor is disconnected!**

- 5 Mount the suction hose to the neck of the upper part of the separator (fig. 59).

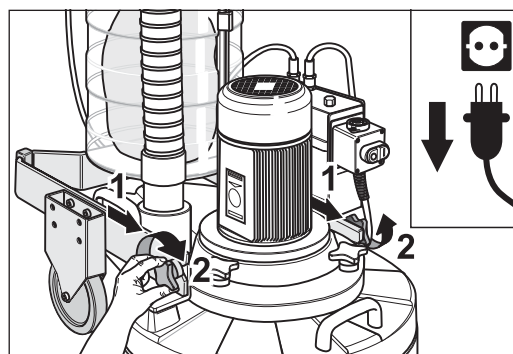

Fig. 55 Roll chassis into attachment position so that the two fasteners can be homed in (1). Tighten the two cross grip fasteners firmly (2).

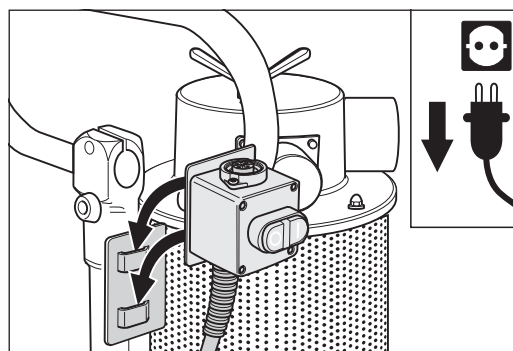

Fig. 56 Hook the switch into holder on the chassis.

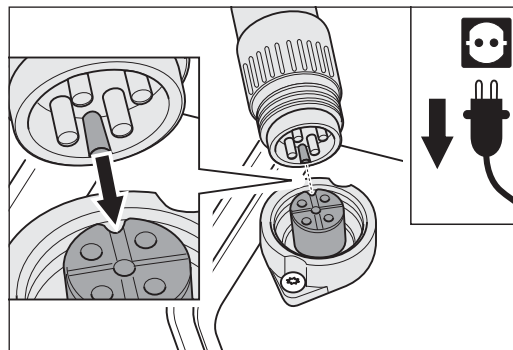

Fig. 57 Insert the cable plug of the sensor into the switch. **Make sure that the nose of the cable plug is inserted into the groove of the socket!**

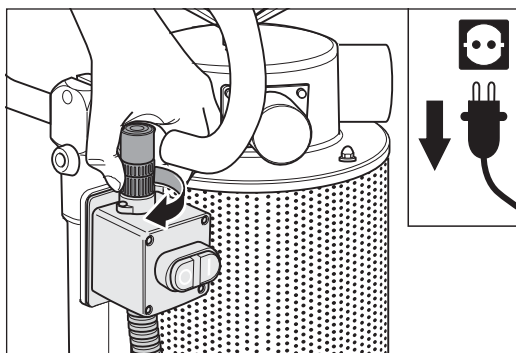

Fig. 58 Lock the cable plug of the sensor by turning the ring nut.

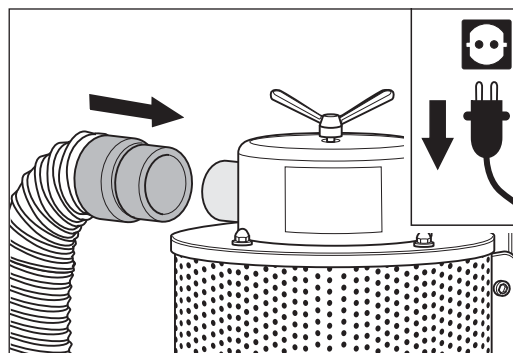

Fig. 59 Mount the suction hose to the neck of the upper part of the separator.

## 6.3 STORAGE

**WARNING!**

**RISK OF FIRE from formation of sparks while sanding:**

**Always store the machine without dust bag!**

If the machine is to be stored for a longer period, make sure it is stored in a dry, frost-free room which is not subject to great fluctuations in temperature.

**Store your unused machine in a dry, closed location out of the reach of children!**

**CAUTION!**

**RISK OF PROPERTY DAMAGE:**

**Remove the sanding plates and milling discs from the machine when the machine is not to be used, because otherwise**

- **the sanding media or milling discs can cause scratches on the ground,**
- **the machine weight can damage the flexible Velcro rings of sanding plates or the indexable inserts of milling discs!**

# Maintenance work and replacement of wearing parts



## **WARNING!**

**RISK OF DEATH from electrical shock and RISK OF INJURY from rotating parts of the machine:**

- All extensive maintenance work, especially on the electrical equipment, **must** be conducted by a qualified expert for safety reasons!
- All maintenance work **must** be conducted with the machine switched off and with the power plug removed from the socket!

**HEALTH RISK caused by dust:**

Since wood dust deposits can be released when the dust separator is dismantled, you have to wear a respiratory protective mask (at least filter class P2) for all work on the dust separator system!



## **CAUTION!**

**RISK OF PROPERTY DAMAGE:**

- Use exclusively original parts from LÄGLER® (part numbers in *Section 11, Spare parts TRIO*)! Only by doing so can the performance of your machine be guaranteed! Warranty claims arising due to the use of externally sourced parts will not be acknowledged!
- Never blow compressed air into the dust separator as otherwise the highly sensitive pressure control sensor could be damaged!

Certain maintenance jobs ought to be performed from time to time, at the latest, however, when damage is established or the red LED of the pressure control sensor lights up. Use only LÄGLER® original spare parts. Perform the job in a clean, brightly lit working environment and follow the directions given in this manual. In the tool bag you will find all the tools needed for the jobs described below.

## 7.1 CLEANING AND CARE



### **WARNING!**

#### **RISK OF FIRE from spontaneous combustion and the formation of sparks while sanding:**

- **There is a high risk of fire when sanding woods with a large amount of resin, oiled or waxed floors or metal! Therefore, the machine must always be cleaned carefully directly after sanding!**
- **Be certain to note the warning notices of the manufacturers of paint, oil and wax!**

### **Never use solvent-based cleaning agents!**

Before starting work you should carry out the following care and maintenance steps to guarantee proper machine function and a first-class sanding result:

- Check the sanding discs, flexible Velcro rings and rubber plugs of sanding plate pulleys for damage.
- Clean the wheels of the machine.
- Carry out a visual inspection of the electrical equipment (motor, switch, cables, plugs, couplings).



## 7.2 CLEANING THE FILTER CARTRIDGE

In general the machine's filter cartridge should be cleaned after each dust bag change; at the latest this should be done when the red LED of the pressure control sensor lights up (fig. 60). If this happens while you are in the middle of a sanding job you may as well finish a half-trodden path first.

If you do not clean the filter cartridge in spite of the red light indicating that this is necessary, the suction performance will become less and less efficient with time, and the dust emission will increase. This, of course, will mean a higher health risk for the machine operator. Furthermore, the cleaning of filter cartridge and dust separator will prove troublesome and time-consuming.

To clean the filter cartridge proceed as follows:

- 1 **Switch off the machine and pull the power plug out of the socket!**
- 2 Grasp and turn the wing nut on top of the dust separator and gently pull it upwards, moving the cleaning slide integrated in the dust separator (fig. 61).
- 3 Now push the cleaning slide gently back down while still continuously turning the wing nut. You will see dust dropping into the dust bag.
- 4 Repeat this process several times until no more dust drops into the dust bag.
- 5 Once you have finished cleaning, make sure the cleaning slide is pushed as deeply as possible back into the dust separator (fig. 62, 1). Otherwise the filter cartridge will be burdened with more dust than necessary and will have to be cleaned more often.
- 6 Insert the power plug into the mains socket (fig. 62, 2). You can now switch the machine back on again (fig. 62, 3).

If you didn't succeed in cleaning the filter cartridge with the cleaning slide or if the intervals in between cleaning become too short, your filter cartridge is probably clogged with deposits such as old varnish or glue residue and must be dismantled for thorough cleaning. *Section 7.3, Changing the filter cartridge* describes the removing and mounting of the filter cartridge.

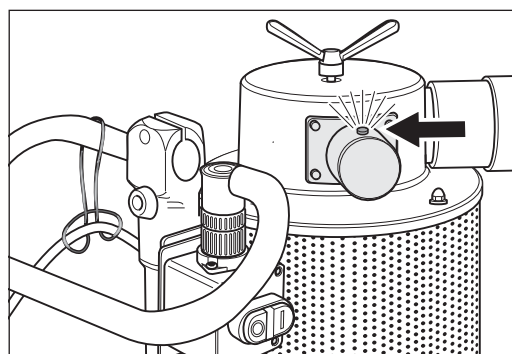

Fig. 60 If the red LED of the sensor lights up, check whether the dust bag is full and the filter cartridge should be cleaned!

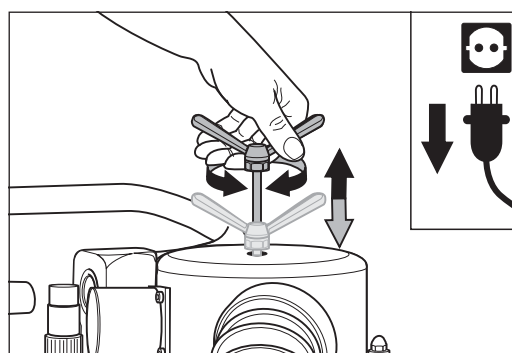

Fig. 61 Move the cleaning slide up and down while continuously turning the wing nut.

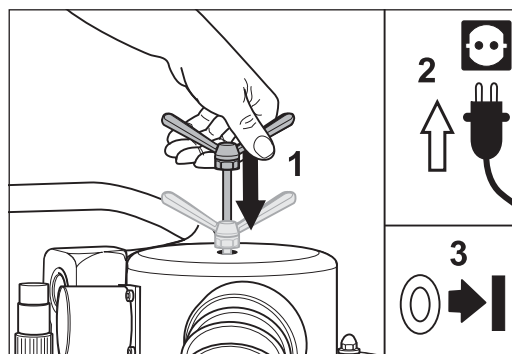

Fig. 62 Push the cleaning slide as deep as possible into the dust separator (1). Insert the power plug into the mains socket (2). You can now switch the machine back on again (3).

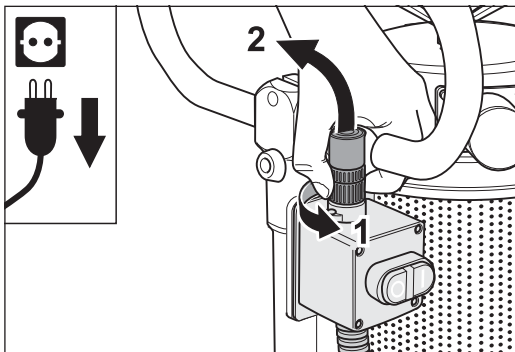

Fig. 63 Loosen the ring nut (1) and remove the cable plug from the switch (2).

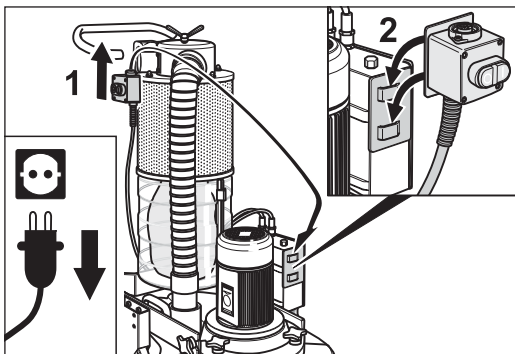

Fig. 64 Hook the on/off switch into the transport holder on motor switch box.

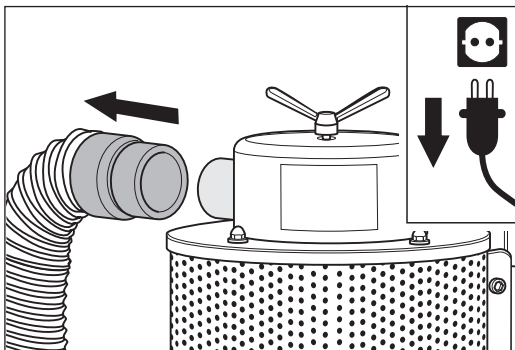

Fig. 65 Pull the suction hose from the neck of the upper part of the separator.

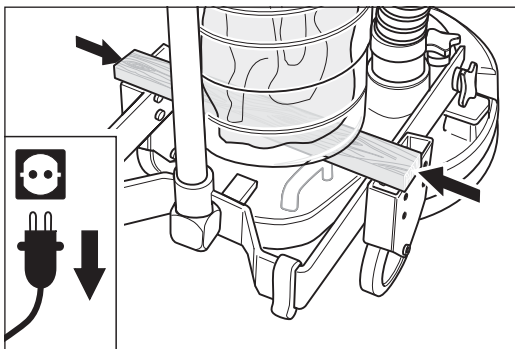

Fig. 66 Place a board between the closed dust bag box and the chassis.

### 7.3 CHANGING THE FILTER CARTRIDGE



#### **WARNING!**

#### **HEALTH RISK caused by dust:**

**Since wood dust deposits can be released when the dust separator is dismantled, you have to wear a respiratory protective mask (at least filter class P2) for all work on the dust separator system!**

Use only original LÄGLER® filter cartridges (part number in *Section 11, Spare parts*).

This section describes how to dismantle and reassemble the filter cartridge. This can become necessary when the filter cartridge is totally clogged by deposits and these cannot be removed by the normal cleaning method (→ *Section 7.2, Cleaning the filter cartridge*) or if the filter cartridge has been damaged in any way.

#### 7.3.1 REMOVING THE FILTER CARTRIDGE

- 1** Switch off the machine and pull the power plug out of the socket!
- 2** Clean the filter cartridge of the dust separator as described in *Section 7.2, Cleaning the filter cartridge*.
- 3** Loosen the cable plug of the sensor on the on/off switch by turning the ring nut **counterclockwise** (fig. 63, 1) and pull the cable plug off (fig. 63, 2).
- 4** Remove the on/off switch from the chassis (fig. 64, 1) and hook it into the transport holder on motor switch box (fig. 64, 2).
- 5** Pull the suction hose from the neck of the upper part of the separator (fig. 65).
- 6** Put a approx. 2 cm (0.8") thick board (e.g. piece of parquet flooring) between the closed dust bag box and the chassis (fig. 66) to prevent the dust bag box from falling off when the upper part of the separator is removed.

## MAINTENANCE WORK AND REPLACEMENT OF WEARING PARTS

- 7 Remove the four cap nuts and washers on top of the dust separator (fig. 67) and lift off the upper part of the separator in one straight move (fig. 68).
- 8 Lift the filter cartridge out of the filter housing (fig. 69). Clean it or replace it by a new one.

### 7.3.2 MOUNTING THE FILTER CARTRIDGE

- 1 Before you insert the filter cartridge, make sure the rubber seals are in the groove on the filter cartridge (fig. 70).
- 2 Slide the filter cartridge onto the four screws from above (fig. 71). **Make sure not to damage the filter cartridge!** The dust separator system will not work properly otherwise.
- 3 Now the upper part of the separator can be replaced (fig. 72). Insert the perforated metal into the upper part of the separator in such a way that it touches the inside of the ridge (fig. 73, 1).

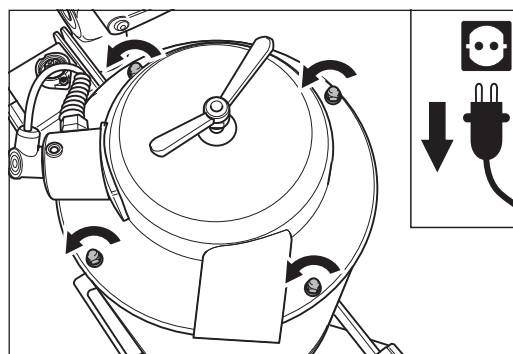

Fig. 67 Remove the four cap nuts and washers on top of the dust separator.

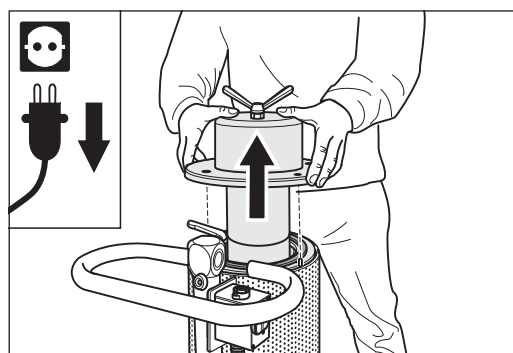

Fig. 68 Lift off the upper part of the separator.

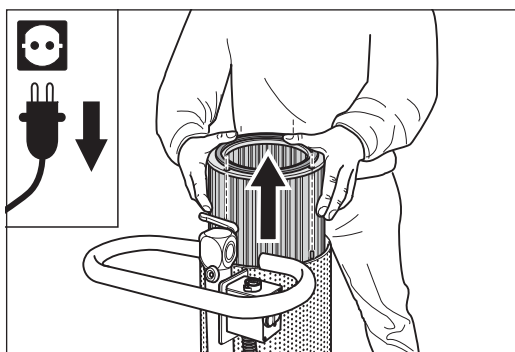

Fig. 69 Lift the filter cartridge out of the filter housing.

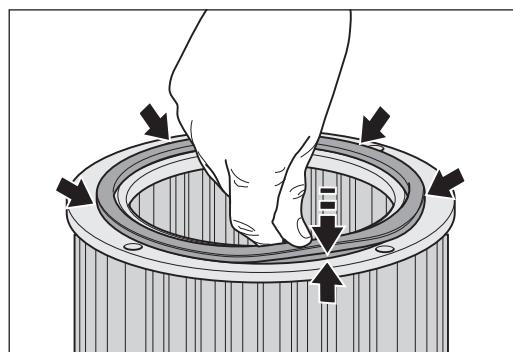

Fig. 70 Make sure the seal sits properly in the filter cartridge before replacing it in the dust separator.

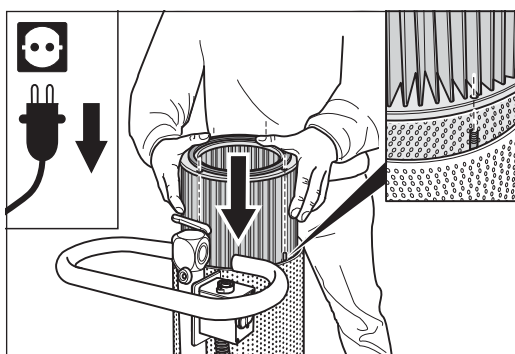

Fig. 71 Slide the filter cartridge onto the four screws from above.

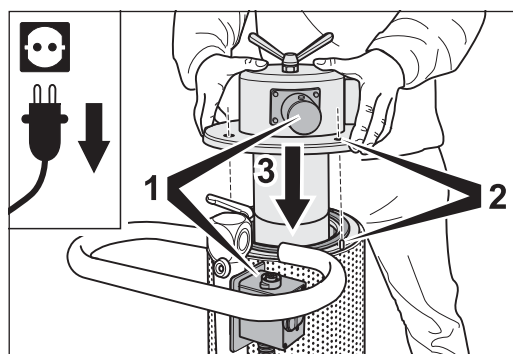

Fig. 72 Position the upper part of the separator (1 + 2) and insert it into the filter cartridge (3).

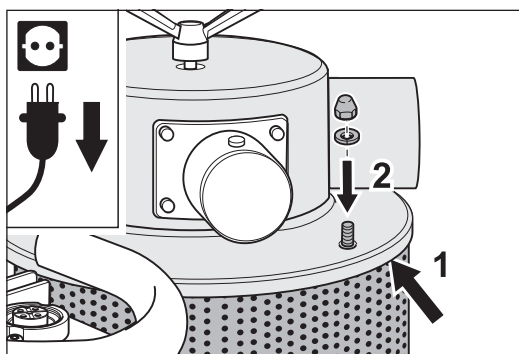

Fig. 73 Insert the perforated metal into the upper part of the separator in such a way that it touches the inside of the ridge (1). Put the washers on the screws and put the cap nuts back on **loosely** (2).

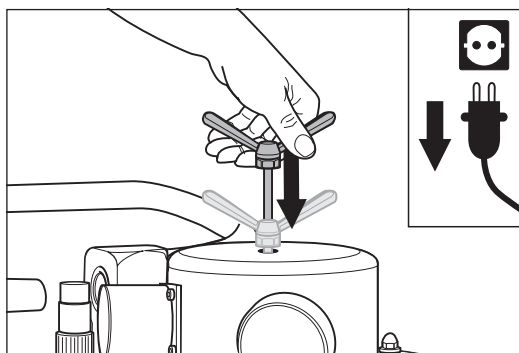

Fig. 74 Push the cleaning slide as far as possible into the dust separator.

- 4 Put the washers on the screws which project out of the upper part of the separator and put the cap nuts back on (fig. 73, 2). Only place these on **loosely, don't tighten** them.
- 5 Now it is time to push the cleaning slide all the way down to centre the system (fig. 74). Otherwise the system will be very hard to work with later.
- 6 Check the relative positions of all the parts again before tightening the cap nuts in a cross-like fashion. Tighten the cap nuts carefully, making sure the upper part of the separator doesn't become bent.
- 7 Reassemble the machine (→ *Section 6.2, Reassembly after transportation, points 3 to 5*).
- 8 The machine is now ready to use again.

## 7.4 CHANGING THE TOOTH BELT

Only use the original LÄGLER® tooth belt (part number in *Section 11, Spare parts TRIO*).

The tooth belt transmits momentum from the motor pinion to the three pulleys of the sanding plates; it is necessary to clean it regularly and to replace it in case of damage.



### CAUTION!

#### RISK OF INJURY:

During dismantling and mounting of the tooth belt take care of your fingers → danger of crushing!

### 7.4.1 REMOVING THE TOOTH BELT

- 1 **Switch off the machine and pull the power plug out of the socket!**
- 2 Remove the sanding plates or the milling discs from the machine (→ *Section 5.2.1, Removing the sanding plates*).
- 3 Remove the eight fixing screws of the cover and remove the cover (fig. 75). Check at this point whether the sealing felt on the inside of the cover needs to be replaced (→ *Section 7.6, Changing the sealing felt on the cover of the inner housing*).
- 4 Loosen counter nut of tooth belt tensioner (using wrench size 17 mm) and turn the nut all the way back to casing wall (fig. 76).
- 5 To expand the spring, now turn the clamping nut back to the counter nut (fig. 77).
- 6 Push the tooth belt tensioner back so that the tooth belt can be removed (fig. 78).
- 7 Suck off dust and dirt using a suitable vacuum cleaner.

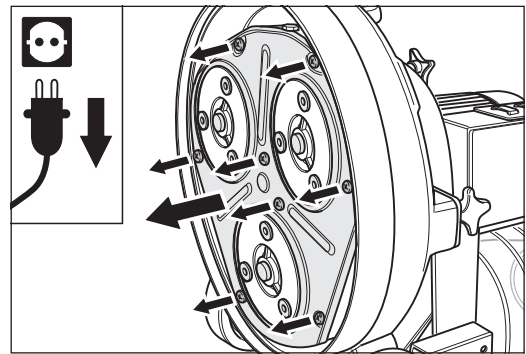

Fig. 75 Remove the eight screws and pull off the cover.

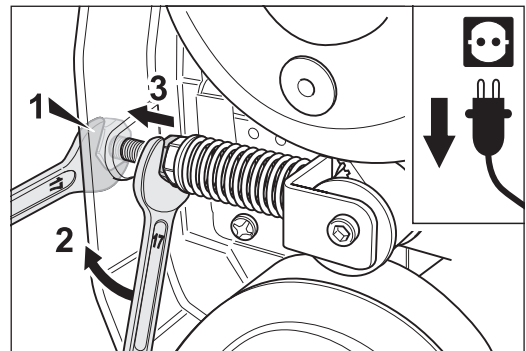

Fig. 76 Turn the counter nut back to the casing wall.

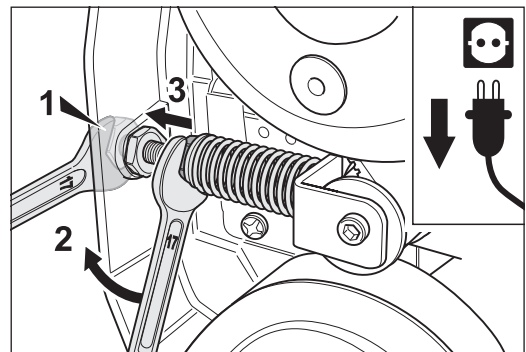

Fig. 77 Turn the clamping nut back to the counter nut.

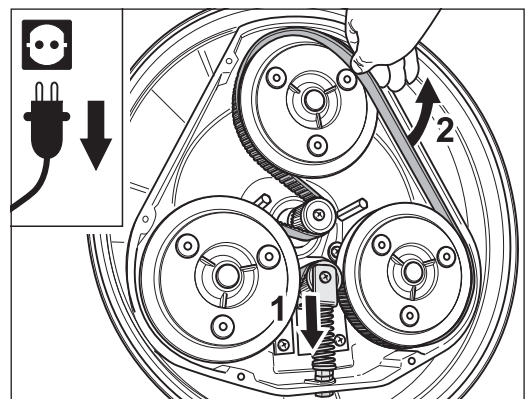

Fig. 78 Push the tooth belt tensioner back (1) and remove the tooth belt (2).

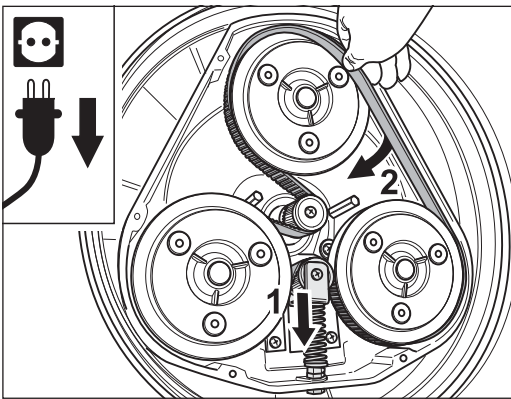

Fig. 79 With the tensioner pulled back (1), insert the tooth belt with the geared side facing and engaging the pinion gearing with the flat side of belt skirting the pulleys (2).

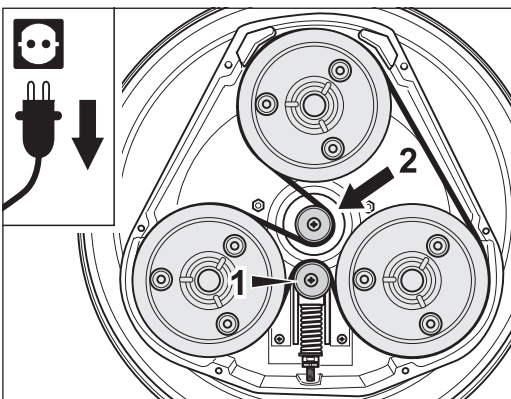

Fig. 80 When the tooth belt tensioner is **at the bottom** (1), place the tooth belt around the **right side** of the drive pinion (2).

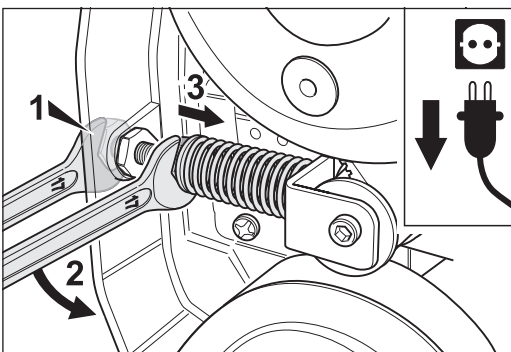

Fig. 81 Twist the clamping nut in order to tighten the spring.

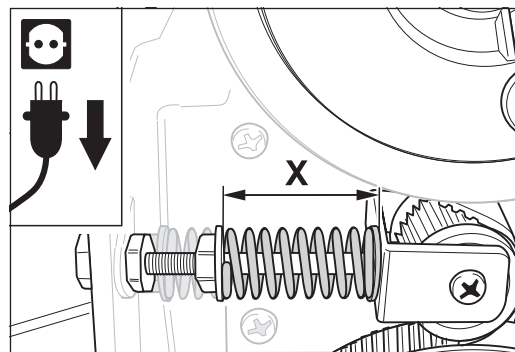

Fig. 82 The length **X** of the tightened spring is:  
 - **orange** spring: 55 mm (approx. 2.2")  
 - **blue** spring: 52 mm (approx. 2").

#### 7.4.2 MOUNTING THE TOOTH BELT

- 1 Push the tooth belt tensioner all the way back to the casing wall (fig. 79, 1).
- 2 Insert the tooth belt with the geared side facing and engaging the pinion gearing with the flat side of the belt skirting the pulleys (fig. 79, 2).

#### **ATTENTION!**

**It is important to insert the tooth belt correctly, as otherwise the machine may suffer damage! When the tooth belt tensioner is at the bottom (fig. 80, 1), the tooth belt has to be placed around the right side of the drive pinion (fig. 80, 2)!**

- 3 Now tighten the spring using the clamping nut (fig. 81), whereby the spring must be tightened to the following length:

Tightened length **X** of the spring (fig. 82)

- **orange** spring: 55 mm (approx. 2.2")
- **blue** spring: 52 mm (approx. 2").

- 4 Twist the counter nut to the clamping nut (fig. 83).
- 5 Carefully fasten the two nuts (fig. 84).
- 6 Put the cover back on in the proper position. The seal must be positioned evenly around the pulleys. Use two screws to hold it in place initially before replacing the other screws (fig. 85).
- 7 Tighten all eight screws equally tight.
- 8 Mount the sanding plates or milling discs of your choice (→ *Section 5.2.2, Mounting the sanding plates*).
- 9 Tilt the machine back into the vertical position and adjust the handle height to your convenience.

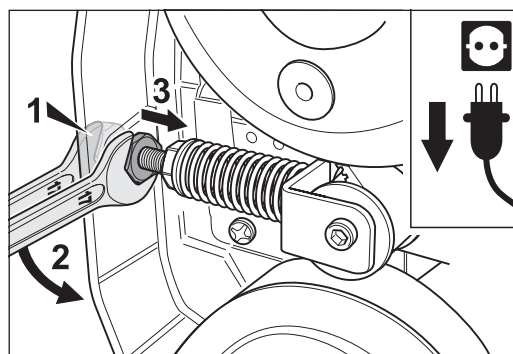

Fig. 83 Twist the counter nut to the clamping nut.

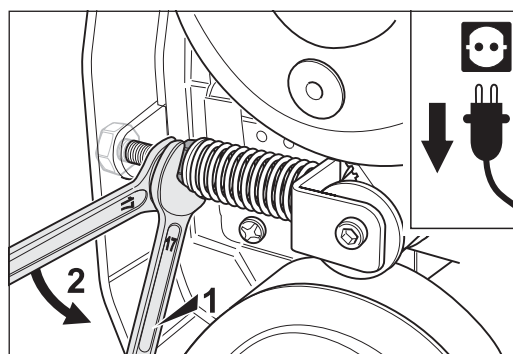

Fig. 84 Carefully fasten the two nuts.

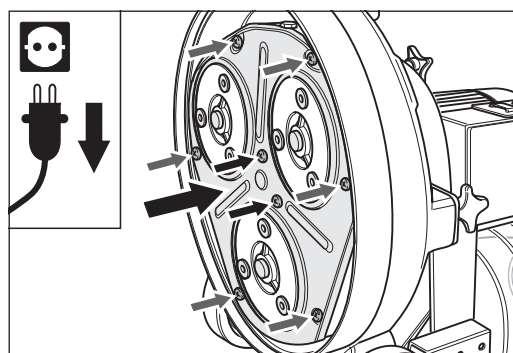

Fig. 85 Replace the cover and fix it in place using the eight screws.

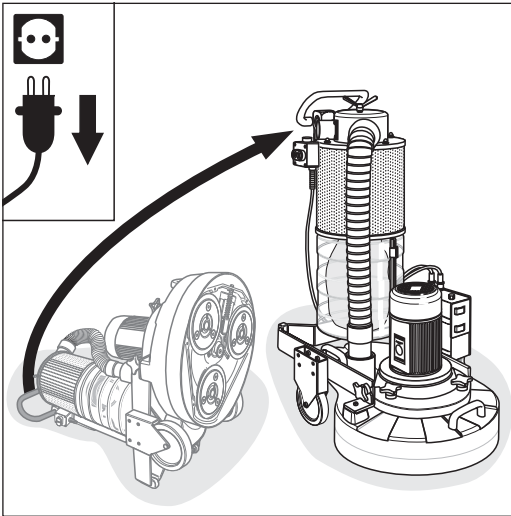

Fig. 86 Bring the machine back into vertical position.

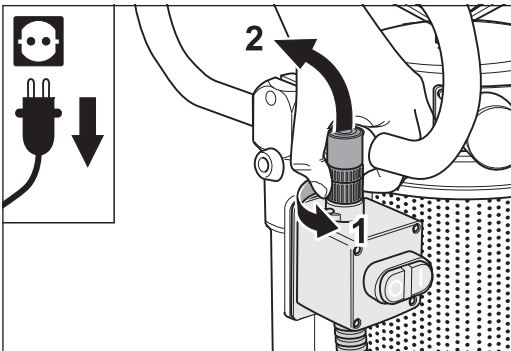

Fig. 87 Loosen the ring nut (1) and remove the cable plug from the switch (2).

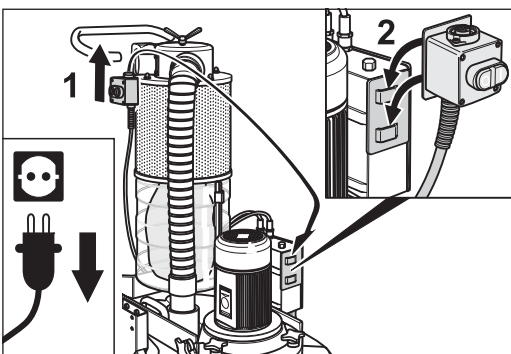

Fig. 88 Hook the on/off switch into the transport holder on motor switch box.

## 7.5 CHANGING THE V-BELT

Always only use original LÄGLER® V-belts (part number in *Section 11, Spare parts TRIO*).

If the V-belt shows signs of wear and tear it needs to be replaced.

### 7.5.1 REMOVING THE V-BELT

- 1 **Switch off the machine and pull the power plug out of the socket!**
- 2 Remove the tooth belt (→ *Section 7.4,1, Removing the tooth belt*).
- 3 Bring the machine back into vertical position (fig. 86).
- 4 Loosen the cable plug of the sensor on the on/off switch by turning the ring nut **counterclockwise** (fig. 87. 1) and pull the cable plug off (fig. 87. 2).
- 5 Remove the on/off switch from the chassis (fig. 88, 1) and hook it into the transport holder on motor switch box (fig. 88, 2).
- 6 Pull the suction hose from the neck of the upper part of the separator (fig. 89).

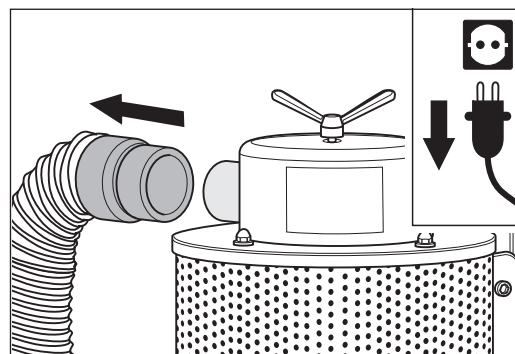

Fig. 89 Pull the suction hose from the neck of the upper part of the separator.



- 7 Loosen the two cross grip fasteners at the side by which chassis is attached to machine housing (fig. 90, 1) and move the chassis backwards (fig. 90, 2).
- 8 Remove the screw which fixes the V-belt guard to the fan insert (fig. 91, 1).
- 9 Pull V-belt guard from its slot at the motor and put it aside (fig. 91, 2).
- 10 Release the tension of the V-belt by carefully moving the V-belt tensioner using cranked closed-mouth wrench. The V-belt can now be disengaged from the pulleys and the belt tensioner (fig. 92).

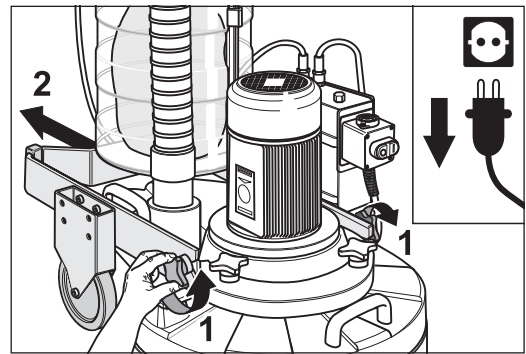

Fig. 90 The chassis can be moved backwards once the cross grip fasteners have been loosened.

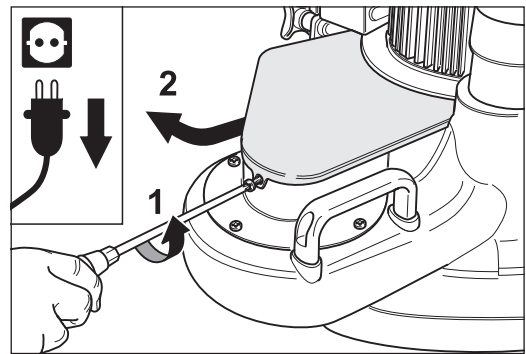

Fig. 91 Remove the V-belt guard fixing screw (1) and remove the V-belt guard (2).

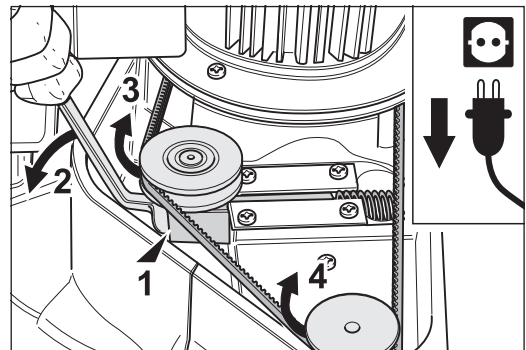

Fig. 92 Release the tension of the V-belt by carefully applying the cranked closed-mouth wrench and moving the belt tensioner as shown.

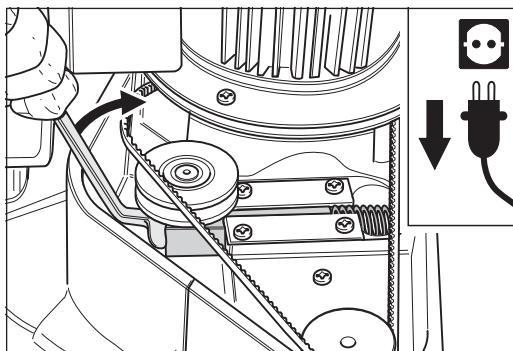

Fig. 93 Release the tensioner into its regular position.

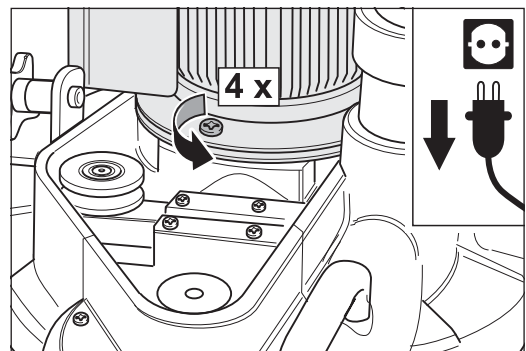

Fig. 94 Remove the four screws which fix the motor to machine housing.



### CAUTION!

#### RISK OF INJURY:

During dismantling of the V-belt take care of your fingers → danger of crushing!

- 11 Release the tensioner into its regular position (fig. 93).
- 12 Remove the four screws which fix the motor to machine housing (fig. 94) and lift the motor off, keeping it in a vertical position. The V-belt can now be removed (fig. 95).
- 13 Suck off dust and dirt using a suitable vacuum cleaner.

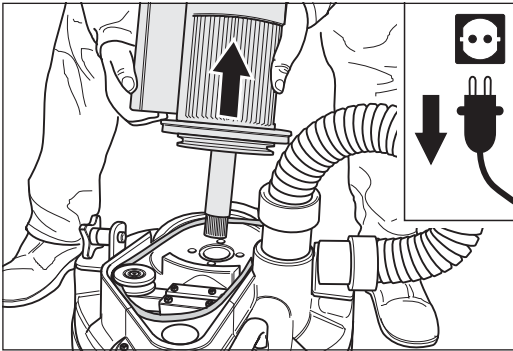

Fig. 95 Lift the motor off the machine housing vertically and remove the V-belt.

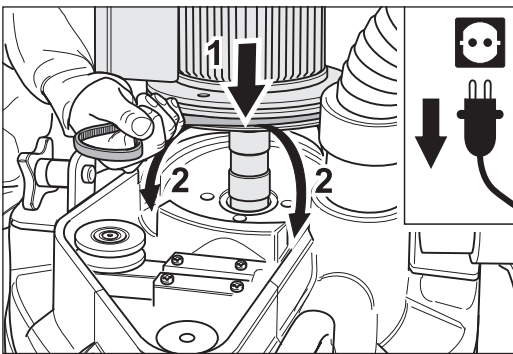

Fig. 96 Loop the new V-belt around the motor pulley (1) and insert the motor. **Make sure the belt is passed through the two recesses on the machine housing (2)!**

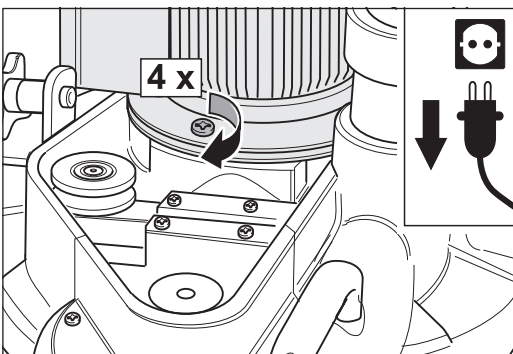

Fig. 97 Fix the motor to the machine housing by homing in the four fixing screws.

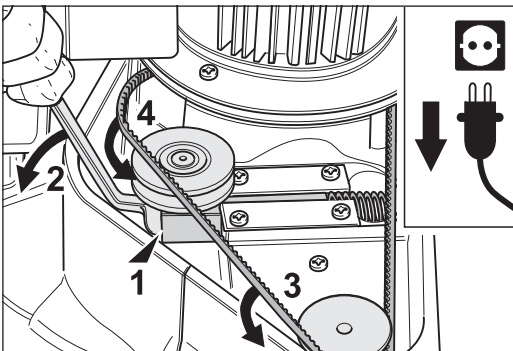

Fig. 98 Insert the closed mouth wrench below the clamping roll (1), move the belt tensioner (2) and insert the V-belt into the pulleys (3 + 4).

### 7.5.2 MOUNTING THE V-BELT

#### **ATTENTION!**

#### **Machines manufactured until 1994:**

**Before placing the motor make sure that the tooth belt tensioner has not fallen out its guides! The tooth belt tensioner cannot be installed with the motor in place!**

#### **Machines manufactured as from 1995:**

**The tooth belt tensioner cannot drop out of its guides anymore!**

- 1 Loop the new V-belt around the motor pulley.
- 2 With V-belt in place, lower motor vertically onto the machine housing (fig. 96, 1). Make sure the V-belt does not slide off the motor pulley and get jammed between the motor and the machine housing. **The belt must be passed through the two recesses on the machine housing (fig. 96, 2)!**
- 3 Fix the motor to the machine housing by homing in the four fixing screws (fig. 97).
- 4 Use the closed mouth wrench to push the tensioner back against the spring (fig. 98, 1 + 2) and place the V-belt into the pulleys of the ventilator and tensioner (fig. 98, 3 + 4). When the V-belt has been inserted you can release the tensioner into its regular position (fig. 99).

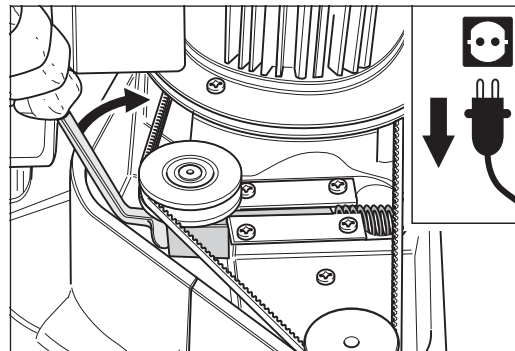

Fig. 99 Release the tensioner into its regular position.

**CAUTION!****RISK OF INJURY:**

**During mounting of the V-belt take care of your fingers → danger of crushing!**

- 5 Insert the V-belt guard into the slot at the motor and push it towards the motor (fig. 100, 1).
- 6 Insert fixing screw for the V-belt guard and tighten it again (fig. 100, 2).
- 7 Reassemble the machine as described in *Section 6.2, Reassembly after transportation*.
- 8 While holding on to the handle, carefully tilt the machine backwards into a horizontal position (fig. 101). Make sure that the machine gets to rest on the guide tube (fig. 102, **A**) and the two protective rubbers (fig. 102, **B**). **Make sure the machine is in a safe position!**
- 9 Mount the tooth belt as described in *Section 7.4.2, Mounting the tooth belt*.

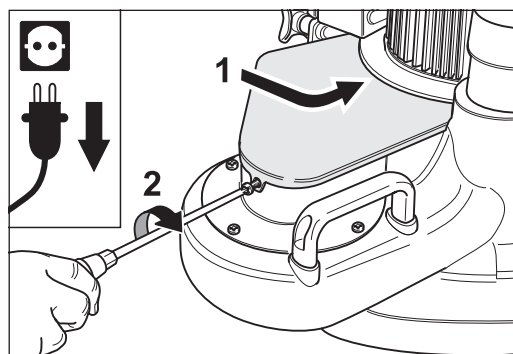

Fig. 100 Insert the V-belt guard into the slot at the motor, push it towards the motor (1) and tighten it with the screw (2).

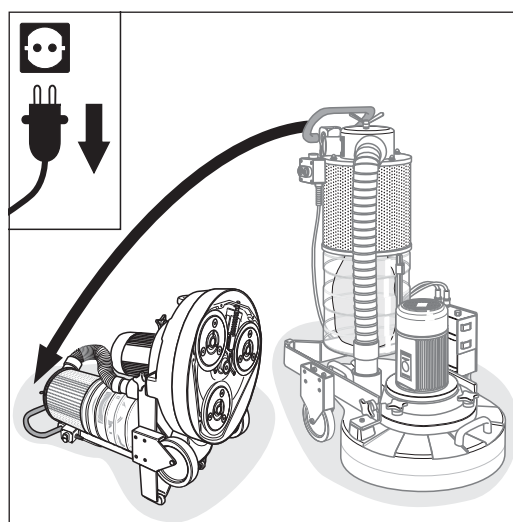

Fig. 101 Carefully tilt the machine backwards.

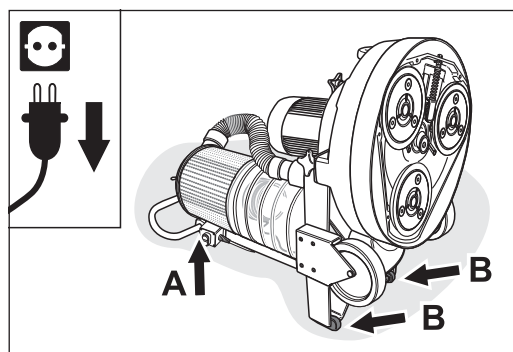

Fig. 102 Make sure that the machine gets to rest on the guide tube (**A**) and the two protective rubbers (**B**). **Make sure the machine is in a safe position!**

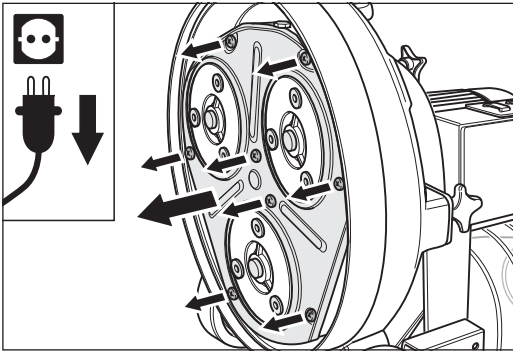

Fig. 103 Remove the eight screws and pull off the cover.

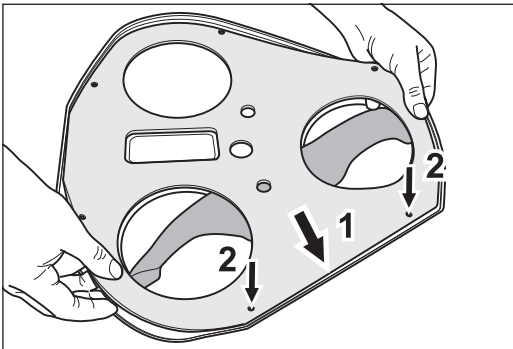

Fig. 104 Position the new sealing felt at one side first before fixing it completely in place.

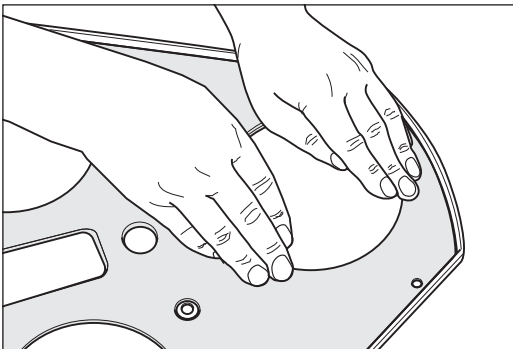

Fig. 105 Press the sealing felt carefully all over, especially at the edges and around the cutaways for the sanding plate pulleys.

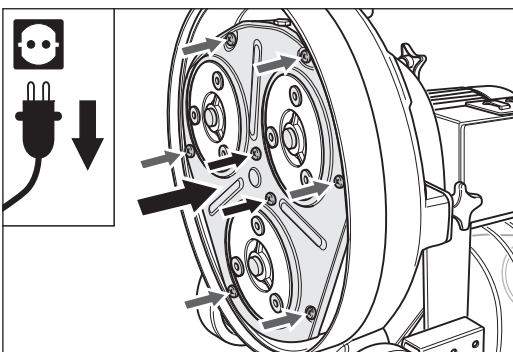

Fig. 106 Replace the cover and fix it in place using the eight screws.

## 7.6 CHANGING THE SEALING FELT ON THE COVER OF THE INNER HOUSING

Only use original LÄGLER® sealing felts (part number in *Section 11, Spare parts TRIO*).

If the sealing felt on the cover of the inner housing shows signs of wear and tear, it must be replaced. This can be recognized by visual inspection, e.g. while changing sanding plates or sanding discs. Too much wear in the area of the sanding plate pulleys allows dust to drift into your drive unit, increasing the abrasion of the tooth belt.

Replace the sealing felt as follows:

- 1** Switch off the machine and pull the power plug out of the socket!
- 2** Remove the sanding plates or the milling discs from the machine (→ *Section 5.2.1, Removing the sanding plates*).
- 3** Remove the eight fixing screws of the cover and remove the cover (fig. 103).
- 4** Pull the worn sealing felt off the inside of the cover and remove all residue adhesive.
- 5** Pull part of the protection paper off the new sealing felt, about a hand wide.
- 6** Position the sealing felt at one side first (fig. 104, 1) before fixing it completely in place. Use the fixing holes in the cover for alignment (fig. 104, 2).
- 7** Press the free part of the sealing felt to the cover, pull off the rest of the protective paper and position the felt carefully. Make sure the positions of the holes in the felt correspond with the fixing holes in the cover.
- 8** Press the sealing felt carefully onto the cover everywhere, especially at the edges and around the cutaways for the sanding plate pulleys (fig. 105).
- 9** Put the cover back on in the proper position. The seal must be positioned evenly around the sanding plate pulleys. Use two screws to hold it in place initially before replacing the other screws (fig. 106).

- 10 Tighten all eight screws equally tight.
- 11 Remount the sanding plates or milling discs as described in *Section 5.2.2, Mounting the sanding plates.*
- 12 The machine is now ready to use.

## 7.7 CHANGING THE RUBBER PLUGS OF THE SANDING PLATE PULLEYS

Only use original LÄGLER® rubber plugs (part number in *Section 11, Spare parts TRIO*).

- 1 **Switch off the machine and pull the power plug out of the socket!**
- 2 Remove the sanding plates or the milling discs from the machine (→ *Section 5.2.1, Removing the sanding plates*).
- 3 Use a screwdriver to prize the rubber plugs out of the sanding plate pulleys (fig. 107, 1).
- 4 Insert the new rubber plugs. **Make sure you have the correct insertion position! The larger diameter of the rubber plugs must be inserted in the hole first (fig. 107, 2)!**
- 5 Remount the sanding plates or milling discs as described in *Section 5.2.2, Mounting the sanding plates.*
- 6 The machine is now ready to use.

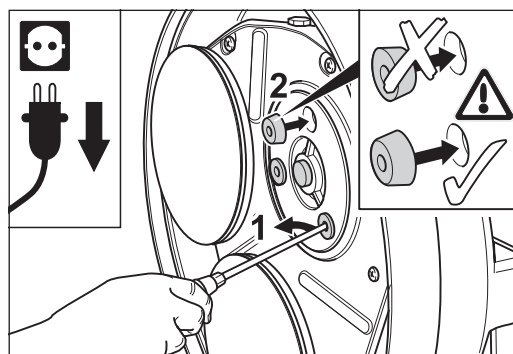

Fig. 107 Replacing the rubber plugs. **Make sure of the correct insertion position!**

# Regular inspection and maintenance work in accordance with accident prevention regulations



## WARNING!

**Tests and testing intervals must comply with and be performed in accordance with the applicable regulations and legal requirements in your country!**

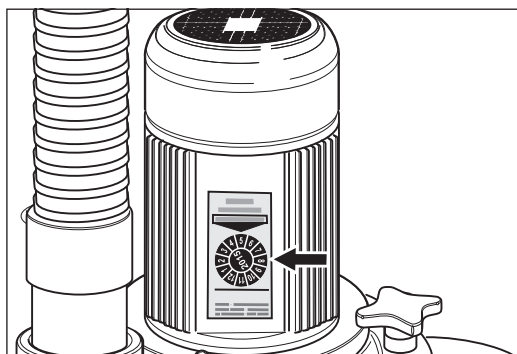

Fig. 108 The inspection label on the motor confirms the electrical and mechanical safety of the machine and indicates when the next maintenance check is due.

The electrical operating equipment and machine parts must be inspected at least once a year by a qualified electrician with respect to electrical and mechanical safety, then be repaired as required. Afterwards, the operational safety must be confirmed by the attachment of an inspection label on the machine (fig. 108).

The elements required for the dust suction system must be checked at least once a year by a qualified expert and repaired as required. The functional efficiency must also be confirmed.

**Ensure that only original LÄGLER® spare parts are used for maintenance work!** You should only allow the customer service work to be conducted by LÄGLER® or an authorized LÄGLER® service centre!

The service passport in these operating instructions (*Section 12*) documents when and where your machine was serviced.

**Enter the serial number and the year of manufacture of your machine (please see the type plate) on the back cover of these operating instructions! If you do not do this, your service passport is invalid!**

Make sure that the maintenance tasks in the service passport are confirmed by filling in a corresponding field with the date, stamp and signature.



## WARNING!

**In order to ensure the safety of the machines and equipment (= working equipment), the German Ordinance on Industrial Safety and Health (BetrSichV) must be complied with in Germany!**

## REGULATIONS VALID IN GERMANY

The German Ordinance on Industrial Safety and Health (BetrSichV) requires every employer to define the testing intervals on the work equipment they provide according to a risk analysis and to document all of this.

**EXCERPT FROM THE BGV A3****§ 5 Inspections**

- (1) The employer must ensure that the proper condition of the electrical systems and equipment is inspected
1. before using the equipment for the first time and other an alteration or repair before being used again by an electrician or under the supervision of an electrician and
  2. at regular intervals.

The intervals are to be calculated in such a manner that defects which must be handled are detected in a timely manner.

- (2) The electrical engineering regulations relevant to the inspection are to be followed.
- (3) Upon request by the professional association, an inspection log with specific entries is to be maintained.
- (4) The inspection before the first commissioning as per paragraph 1 is not required if the employer receives confirmation from the manufacturer or installer that the electrical systems and equipment have been correspondingly procured in accordance with these accident prevention guidelines.

**Table 1B:** Recurring inspections of portable electrical equipment:**Systems/equipment** (which are to be inspected)

- portable electrical equipment (insofar as is used)
- extension and device connection cables with plugs
- connection cables with plugs
- movable cables with plugs and fixed connections

**Inspection interval**

Every 6 months as a reference value, **3 months on construction sites\***).

If an error rate of less than 2% is reached during the inspection, the inspection interval can be extended to a maximum of 1 year (valid for machines on construction sites, in production facilities and workshops).

\*) See the BG information "Selection and Operation of Electrical Systems and Equipment on Construction Sites" (BGI 608) for more details.

**Type of inspection**

The proper condition of the machines and equipment must be inspected.

**Inspector**

Electricians or persons trained in electrical engineering when using suitable measurement and inspection devices.

**NOTE:**

- All LÄGLER® machines and electrical equipment are subjected to an electrical inspection as well as a thorough visual and functional test before they leave the factory.
- A recurring inspection of the machines and electrical equipment must be conducted in Germany at certain intervals.
- LÄGLER® recommends using the guidelines of BGV A3 for inspections and inspection intervals.
- You can, of course, arrange for repairs and recurring inspections of LÄGLER® machines to be conducted by the LÄGLER® service department.

# Causes of faults



## **WARNING!**

### **RISK OF DEATH from electrical shock:**

**Work on the electrical equipment is to be conducted exclusively by a qualified electrician! The machine must be switched off and the power plug removed from the socket during this work!**

**The circuit diagram valid for your machine is located in the motor switch box!**

### **RISK OF INJURY due to unsuitable parts:**

**Make sure that only original LÄGLER® spare parts and original LÄGLER® accessories are used!**

This section shows you how to remedy possible malfunctions. If none of the measures listed here are successful, please contact our service department, your retailer or your importer.

## 9.1 THE MACHINE DOES NOT RUN OR HAS SWITCHED OFF AUTOMATICALLY

- The machine is not connected to the electrical network. Check the following items:
  - Is the motor cable connected to the extension cable?
  - Is the extension cable inserted into the power socket?
- The cable plug of the sensor is not inserted into the on/off switch.
  - ➔ *Section 6.2, Reassembly after transportation, point 4*
- The fuse inside the switch box of the motor is blown. The reason for the blowing must be eliminated professionally and the fuse be replaced. Two replacement fuses can be found inside the switch box (part number in *Section 11, Spare parts TRIO*).
- The power socket is not properly connected. This error must be corrected by an expert.
- The electrical safety device of the electrical network interrupted the electrical circuit, e.g. because
  - too many electricity consumers are connected to the same electrical circuit,
  - improper electrical installation.
 The causes for the error must be repaired by an expert.
- The electrical network is not providing sufficient voltage (undervoltage). Use a transformer if necessary (e.g. LÄGLER® part number 708.00.00.100 for 230 V).



- The temperature switch in the motor has switched off the machine because
  - the power cables have a total length of more than 20 m (790"),
  - the power cables have wire cross-sections which are too small:
    - at mains voltage 220 V or 230 V are the wire cross-sections smaller than 2.5 mm<sup>2</sup> (0.0039 sq.in.),
    - at mains voltage 400 V are the wire cross-sections smaller than 1.5 mm<sup>2</sup> (0.0023 sq.in.),
  - or too much pressure was applied to the sanding plates or milling discs while sanding.

The motor must cool off and the causes for the problems named above must be remedied.
- An electrical component of the machine (e.g. capacitors, contactor, fuse inside the switch box, cable, switch) is defective and must be inspected by a qualified electrician and replaced if necessary.

## 9.2 THE MACHINE ATTEMPTS TO START UP BUT IS NOT ABLE TO DO SO

- The plates are not unloaded when switching on the machine.  
➔ *Section 4.3, Switching on the machine*
- At low temperatures: The machine is too cold and must be heated up to room temperature in a warm room.
- Cables which are too long or too thin are used for the electrical connection:
  - The power cables have a total length of more than 20 m (790").
  - The power cables have wire cross-sections which are too small:
    - at mains voltage 220 V or 230 V are the wire cross-sections smaller than 2.5 mm<sup>2</sup> (0.0039 sq.in.),
    - at mains voltage 400 V are the wire cross-sections smaller than 1.5 mm<sup>2</sup> (0.0023 sq.in.).

This causes of faults lead to a loss of power and are not allowed for safety reasons!
- The electrical network is not providing sufficient voltage (undervoltage). Use a transformer if necessary (e.g. LÄGLER® part number 708.00.00.100 for 230 V).
- The tooth belt is too tight and must be loosened.  
➔ *Section 7.4, Changing the tooth belt*

### 9.3 THE MACHINE RUNS BUT HAS NO OR VERY LITTLE SANDING POWER CAPACITY

- Sanding plates: The sanding medium is incorrect or dull and must be replaced.  
➔ *Section 5.3, Changing the sanding media*
- Milling discs: The indexable inserts are dull or damaged and must be turned or replaced.  
➔ *Section 5.4, Working with milling discs*
- The sanding plates or milling discs are not mounted properly and must be fixed correctly.  
➔ *Section 5.2, Changing the sanding plates*
- At low temperatures: The machine is too cold and must be heated up to room temperature in a warm room.
- Cables which are too long or too thin are used for the electrical connection:
  - The power cables have a total length of more than 20 m (790").
  - The power cables have wire cross-sections which are too small:
    - at mains voltage 220 V or 230 V are the wire cross-sections smaller than 2.5 mm<sup>2</sup> (0.0039 sq.in.),
    - at mains voltage 400 V are the wire cross-sections smaller than 1.5 mm<sup>2</sup> (0.0023 sq.in.).

This causes of faults lead to a loss of power and are not allowed for safety reasons!
- The electrical network is not providing sufficient voltage (undervoltage). Use a transformer if necessary (e.g. LÄGLER® part number 708.00.00.100 for 230 V).
- The tooth belt is not tight enough and must be tightened a bit.  
➔ *Section 7.4, Changing the tooth belt*

## 9.4 THE MACHINE VIBRATES INTENSELY AND RUNS NOISILY

- Sanding plates: The sanding media are not centred or not fixed properly to the sanding plates. This must be corrected correspondingly.  
➔ *Section 5.3, Changing the sanding media*
- Milling discs: The indexable inserts and/or holders are not mounted properly or not arranged symmetrical on the milling discs. This must be corrected.  
➔ *Section 5.4, Working with milling discs*
- Sanding plates: The sanding medium is damaged or incorrect and must be replaced.  
➔ *Section 5.3, Changing the sanding media*
- Milling discs: The indexable inserts are dull or damaged and must be turned or replaced.  
➔ *Section 5.4, Working with milling discs*
- Sanding plates: At least one of the flexible Velcro rings is damaged and must be replaced.  
➔ *Section 5.3, Changing the sanding media*
- The configurations of the three sanding plates or milling discs differ from each other. Always use three sanding plates or milling discs with identical configurations.  
➔ *Section 5.3, Changing the sanding media*  
➔ *Section 5.4, Working with milling discs*
- The sanding plates or milling discs are not mounted properly and must be fixed correctly.  
➔ *Section 5.2, Changing the sanding plates*
- The V-belt or the tooth belt is dirty, damaged or worn-out and must be cleaned or replaced.  
➔ *Section 7.4, Changing the tooth belt*  
➔ *Section 7.5, Changing the V-belt*
- A pulley is dirty, damaged or worn-out and must be cleaned or replaced.  
➔ *Section 7.4, Changing the tooth belt*  
➔ *Section 7.5, Changing the V-belt*
- There are clogged materials and deposits in the machine that must be removed.
- The two cross grip fasteners used for fixing the frame to the machine housing are loose and must be tightened.  
➔ *Section 6.2, Reassembly after transportation*

## 9.5 THE MACHINE RUNS BUT CREATES A GREAT DEAL OF DUST

- The filter cartridge in the dust separator must be cleaned.  
➔ *Section 7.2, Cleaning the filter cartridge*
- The cleaning slide of the dust separator must be pushed back into the dust separator until the limit stop.  
➔ *Section 7.2, Cleaning the filter cartridge*
- The dust bag is full or damaged and must be replaced.  
➔ *Section 5.5, Changing the dust bag*
- The dust bag is not correctly attached.  
➔ *Section 5.5, Changing the dust bag*
- The Velcro sealing tape at the machine housing is not mounted correctly or damaged and must be corrected or replaced.  
➔ *Section 4.1, Preparing the machine, point 11.*
- The filter cartridge in the dust separator is damaged and must be replaced.  
➔ *Section 7.3, Changing the filter cartridge*
- The pressure control sensor fixed to the dust separator is dirty or damaged and must be cleaned or replaced. Use a soft brush for cleaning (never compressed air)!
- The dust separator leaks. The proper assembly must be controlled and its components be checked for damage. Damaged parts must be replaced.  
➔ *Section 7.3, Changing the filter cartridge*
- The sealing felt on cover of inner housing is damaged or worn out and must be replaced.  
➔ *Section 7.6, Changing the sealing felt on the cover of the inner housing*
- The suction hose between dust separator and machine housing has not been fitted properly or is damaged. It has to be fitted correctly or replaced.
- There are clogged materials and deposits in the machine that must be removed.
- The V-belt is damaged or worn-out and must be replaced.  
➔ *Section 7.5, Changing the V-belt*

## 9.6 SANDING PROBLEMS (WAVES, STRIPS, GROOVES)

---

- The floor was not vacuumed before sanding. The floor must be vacuumed thoroughly always directly before each sanding step.
- The sanding medium is damaged or incorrect and must be replaced.  
➔ *Section 5.3, Changing the sanding media*
- Sanding plates: At least one of the flexible Velcro rings is damaged and must be replaced.  
➔ *Section 5.3, Changing the sanding media*
- Sanding plates: The sanding media are not centred or not fixed properly to the sanding plates. This must be corrected correspondingly.  
➔ *Section 5.3, Changing the sanding media*
- The configurations of the three sanding plates differ from each other. Always use three sanding plates with identical configurations.  
➔ *Section 5.3, Changing the sanding media*
- The sanding plates or milling discs are not mounted properly and must be fixed correctly.  
➔ *Section 5.2, Changing the sanding plates*
- The wheels are dirty or damaged and must be cleaned or replaced.
- The machine guidance is either too fast and must be slowed down or it is executed with an irregular speed.

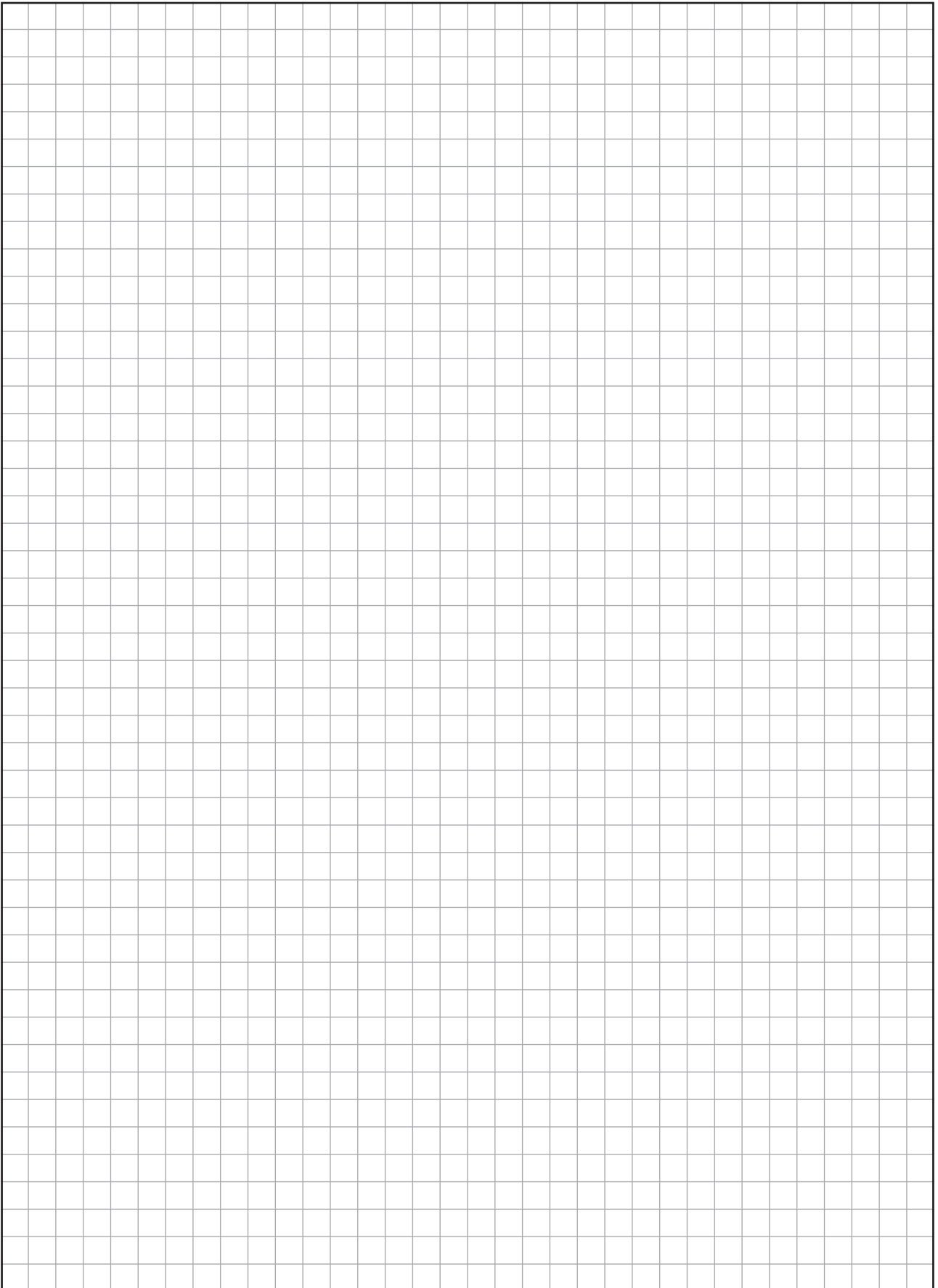

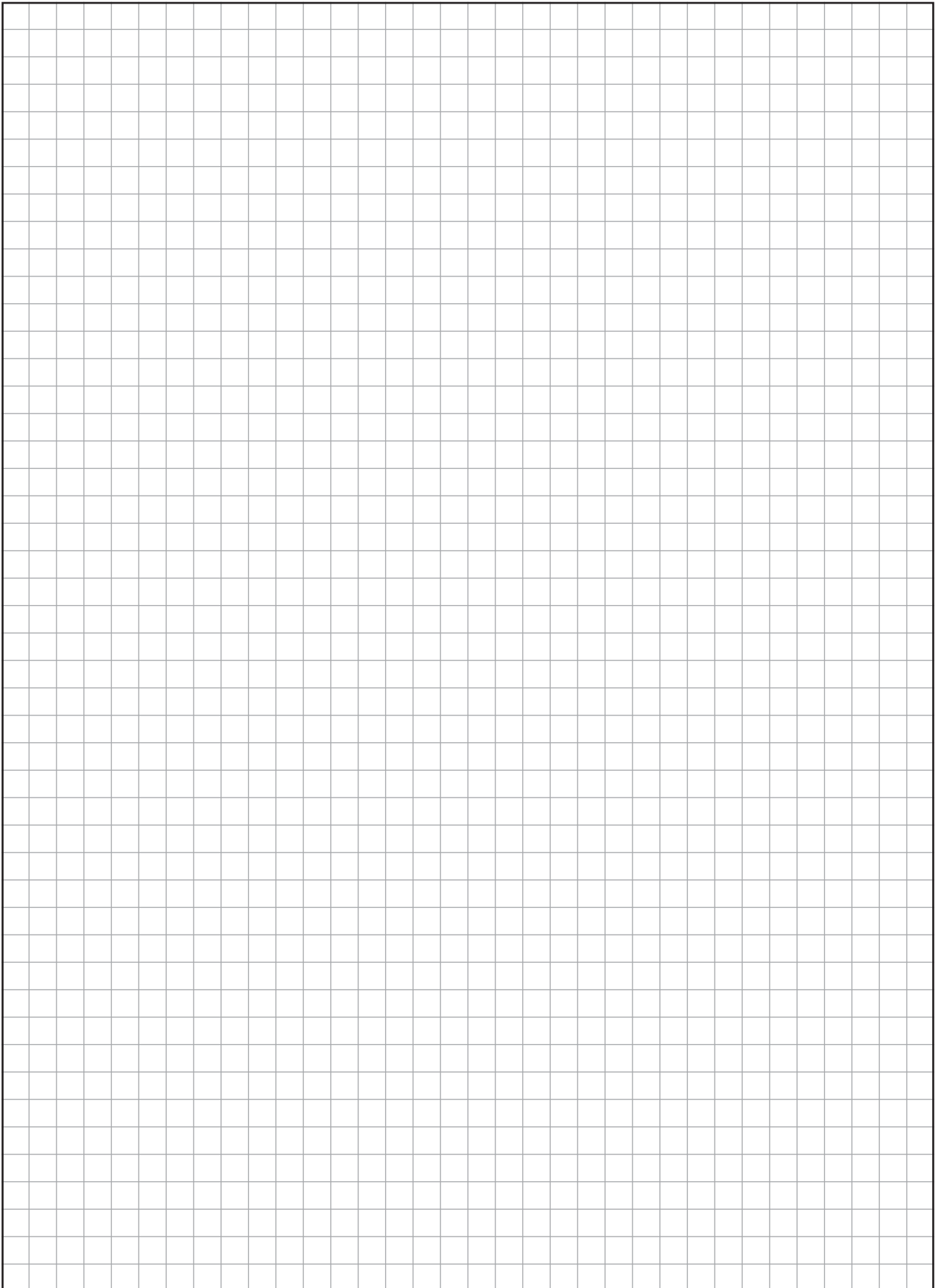

CIRCUIT DIAGRAMS

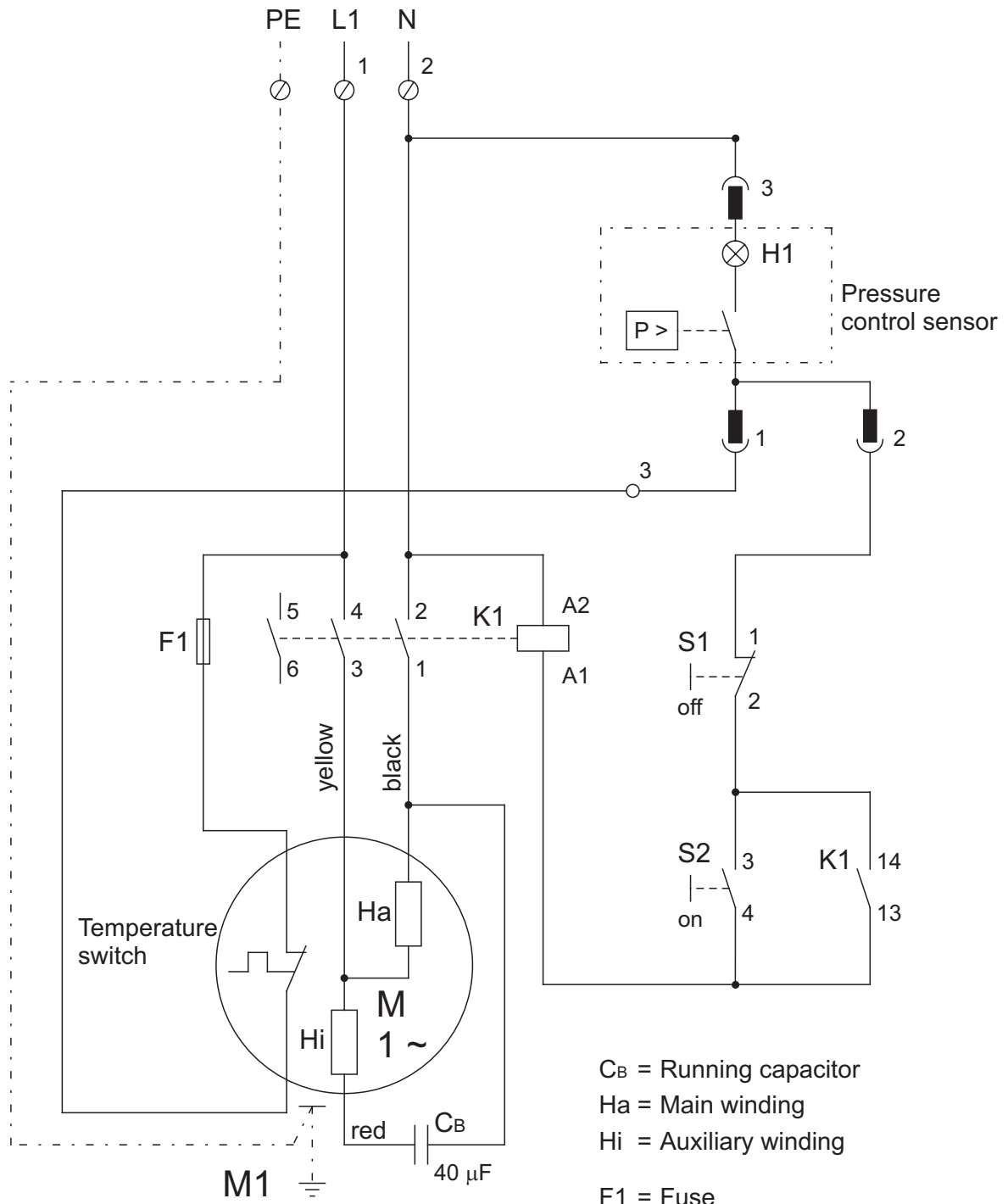

**M1**  
 Motor 1.8 kW  
 230 V / 50 CPS  
 230 V / 60 CPS  
 220 V / 60 CPS, USA

CB = Running capacitor  
 Ha = Main winding  
 Hi = Auxiliary winding  
 F1 = Fuse  
 H1 = Lamp  
 K1 = Contactor  
 S1 / S2 = Switch  
 10.06.1996

<b>TRIO: Single-phase AC motor</b>		1.8 kW / 230 V / 50 CPS 1.8 kW / 220 + 230 V / 60 CPS
EUGEN LÄGLER GMBH Kappelrain 2 D-74363 Güglingen-Frauenzimmern	Phone: 0049 - 7135 - 98 90 - 0 Fax: 0049 - 7135 - 98 90 - 98	e-mail: info@laegler.com Internet: http://www.laegler.com

You will find the circuit diagram valid for your machine in the motor switch box.



CIRCUIT DIAGRAMS

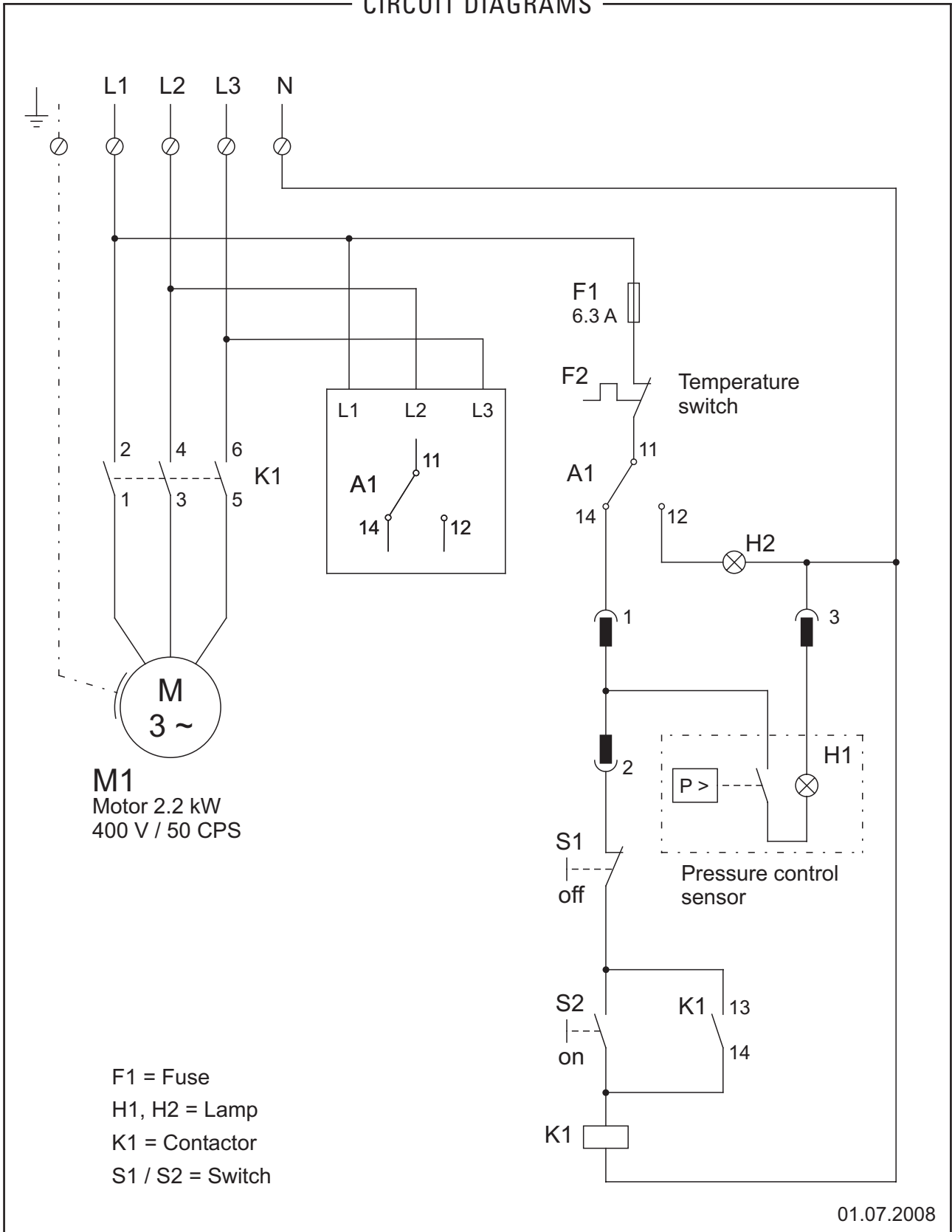

TRIO: Three-phase AC motor		2.2 kW / 400 V / 50 CPS
EUGEN LÄGLER GMBH Kappelrain 2 D-74363 Güglingen-Frauenzimmern	Phone: 0049 - 7135 - 98 90 - 0 Fax: 0049 - 7135 - 98 90 - 98	e-mail: info@laegler.com Internet: http://www.laegler.com

You will find the circuit diagram valid for your machine in the motor switch box.

SPARE PARTS TRIO

ATTENTION: Please specify in inquiries and spare part orders always the serial numbers (→ Section 3.1)!

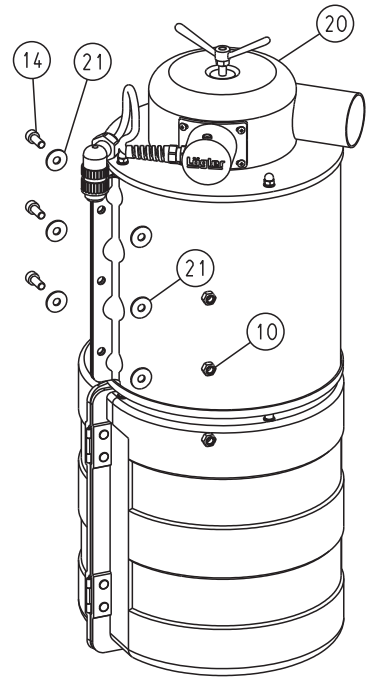
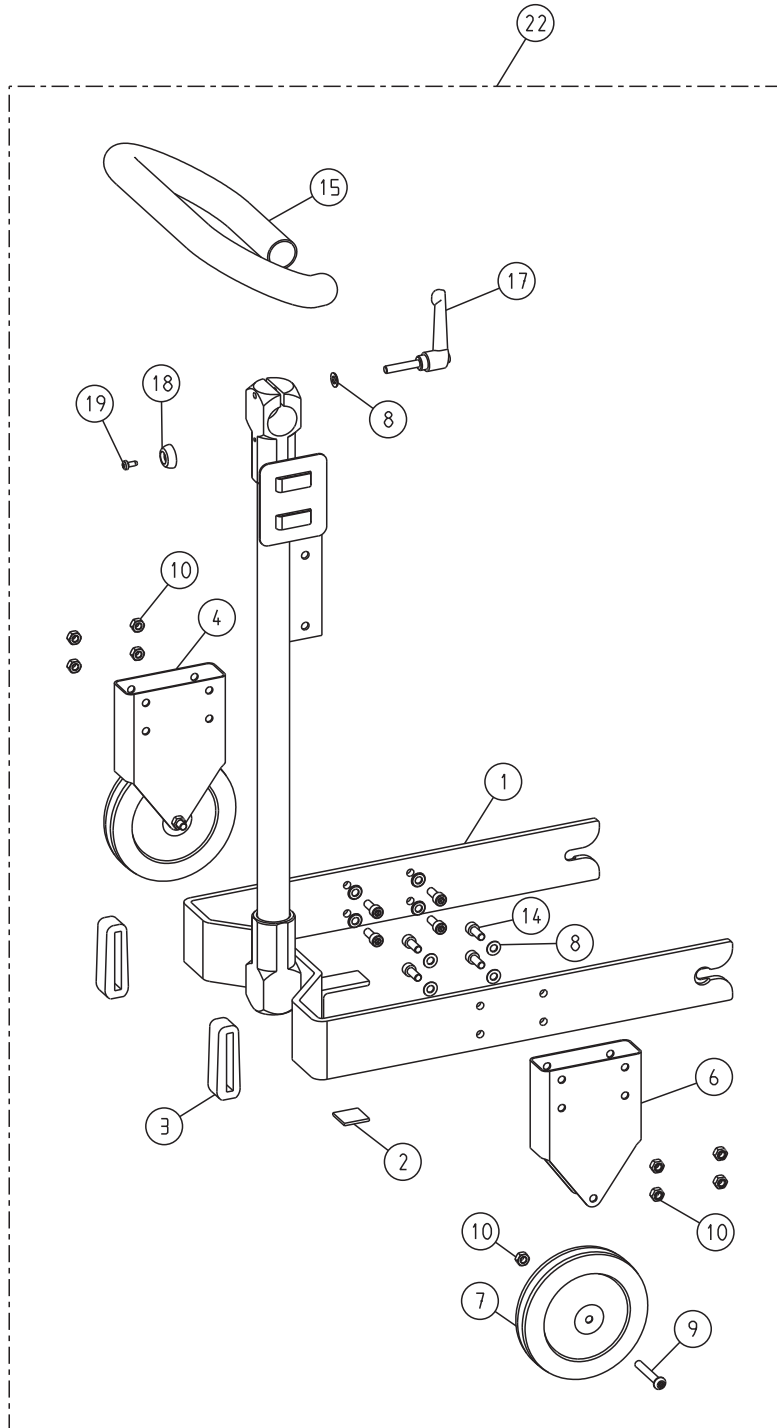

TRIO 1  
01.04.2014

## SPARE PARTS TRIO

Item	Part number	Description
1	900.70.05.100	Frame, complete
2	900.70.25.105	Bumper felt
3	900.70.80.105	Protective rubber
4	900.70.36.100	Wheel, complete
6	900.70.34.100	Wheel holder
7	900.70.32.105	Wheel
8	0125.1008.000	Washer
9	7380.1008.055	Screw
10	0980.1008.000	Nut
14	0912.1008.020	Screw
15	900.70.70.300	Handle
17	000.20.40.081	Clamping device
18	900.70.52.105	Rubber buffer
19	7500.1005.012	Screw
20	900.00.16.100	Dust separator, complete
21	9021.0208.000	Washer
22	900.70.00.100	Chassis, complete

ATTENTION: Please specify in inquiries and spare part orders always the serial numbers of your machines (→ Section 3.1)!

SPARE PARTS TRIO

ATTENTION: Please specify in inquiries and spare part orders always the serial numbers of your machines (→ Section 3.1)!

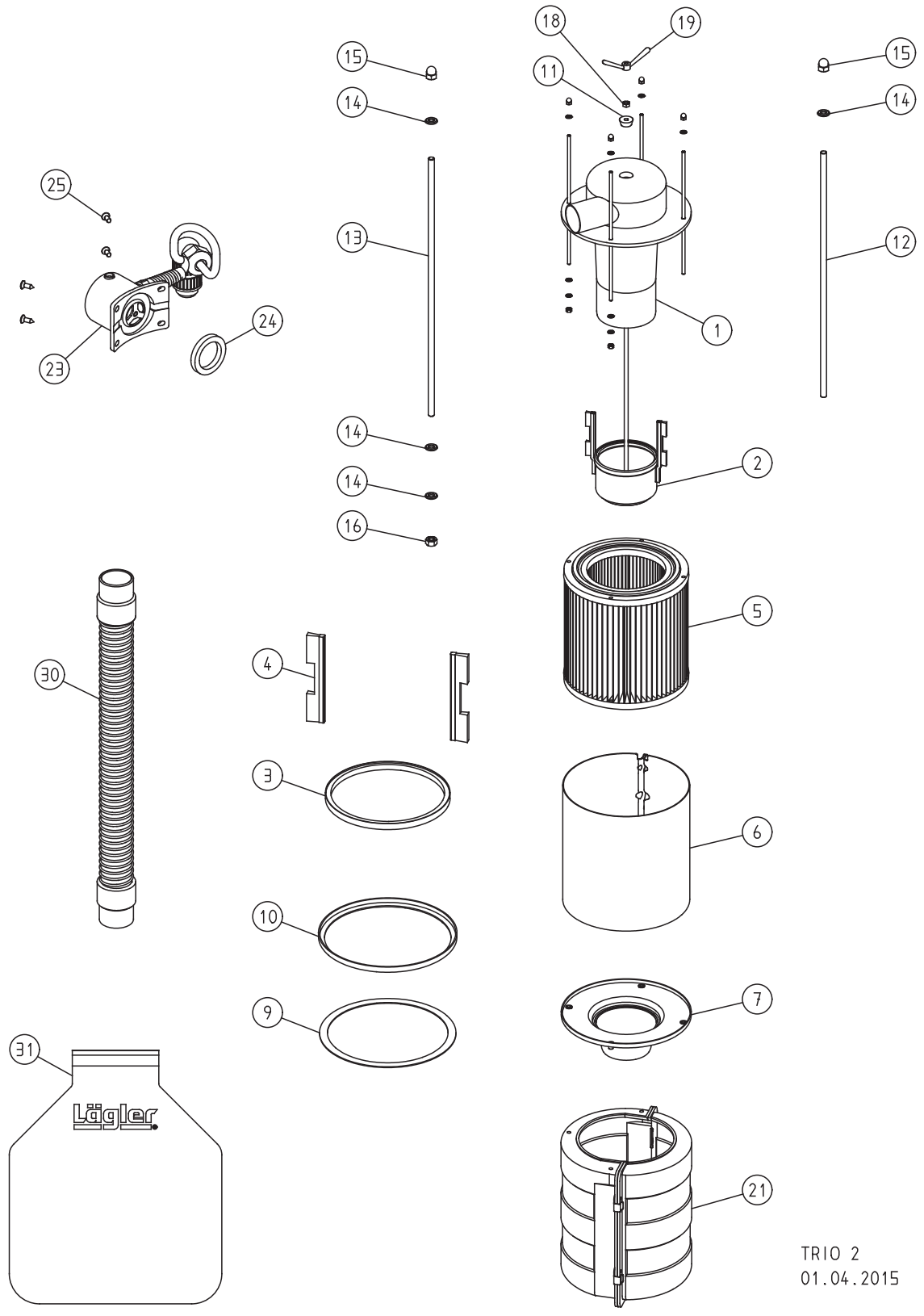

TRIO 2  
01.04.2015

## SPARE PARTS TRIO

Item	Part number	Description
1	900.16.10.100	Separator upper part
2	900.16.21.100	Opener, complete
3	900.16.23.100	Sealing brush
4	900.16.45.105	Filter brush
5	900.16.18.105	Filter cartridge
6	900.16.19.100	Protective cover
7	900.16.17.100	Cover lower separator, complete
9	900.16.25.105	Sealing
10	900.16.22.100	Ring
11	900.03.30.105	Rubber plug with hole
12	900.16.27.105	Screw, short
13	900.16.26.105	Screw, long
14	0125.1006.000	Washer
15	1587.1006.000	Cap nut
16	0980.1006.000	Nut
18	0934.1008.000	Nut
19	000.20.45.083	Wing nut
21	900.17.00.200	Dust bag box, complete
23	900.15.00.100	Pressure control sensor, complete
24	900.15.40.100	Sealing washer
25	7983.1042.013	Screw
30	900.14.00.105	Hose
31	900.00.80.105	Disposable dust bag TRIO (25 pieces per carton)

ATTENTION: Please specify in inquiries and spare part orders always the serial numbers of your machines (→ Section 3.1)!

SPARE PARTS TRIO

ATTENTION: Please specify in inquiries and spare part orders always the serial numbers of your machines (→ Section 3.1)!

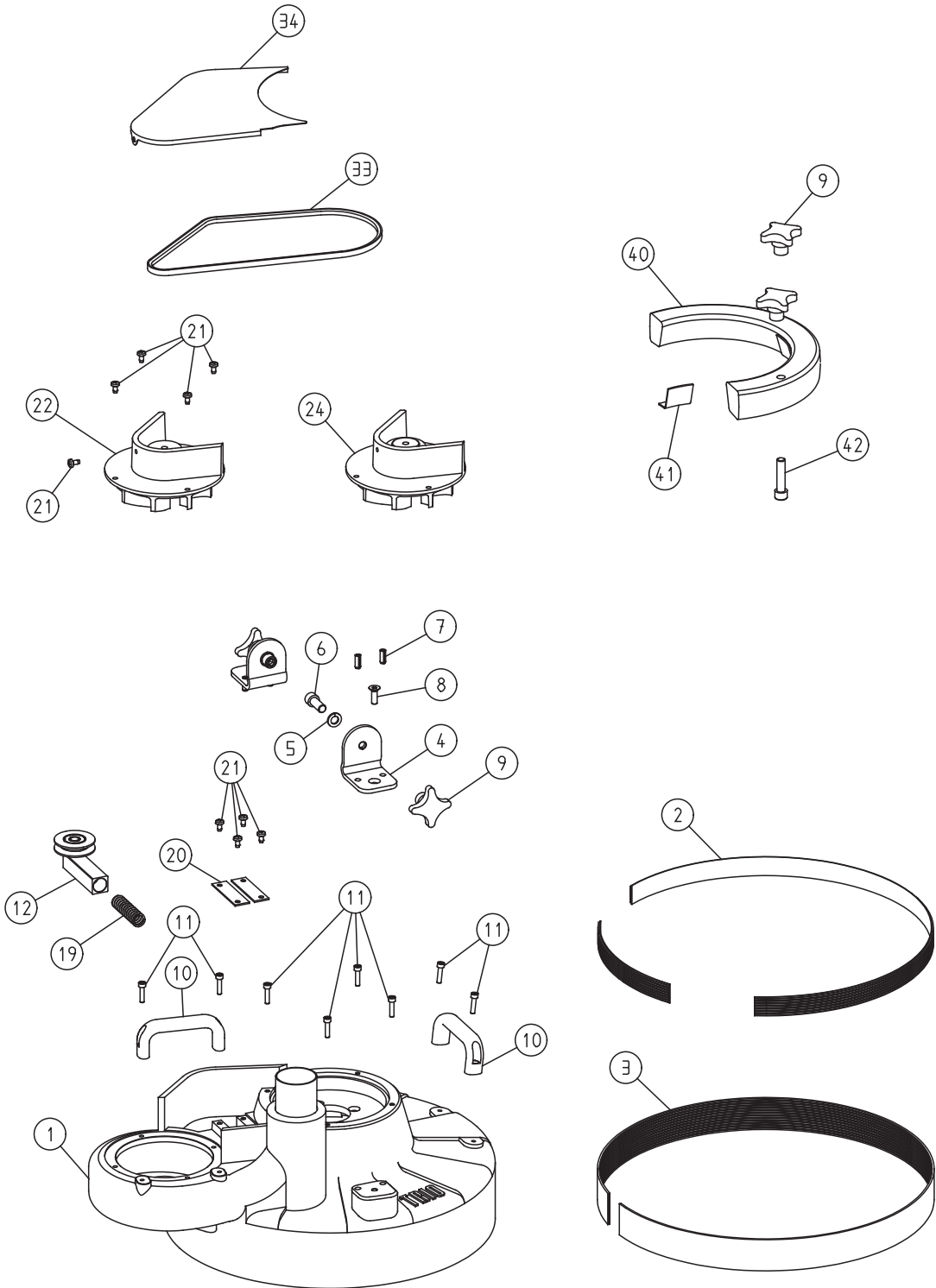

TRIO E  
31.10.2002

## SPARE PARTS TRIO

Item	Part number	Description
1	900.01.10.200	Machine housing
2	900.01.42.100	Self-adhesive Velcro negative
3	900.01.50.100	Velcro seal
	900.01.50.105	Velcro seal TRIO by the roll (50 m)
4	900.01.60.100	Angle
5	0127.1012.000	Spring washer
6	0912.1012.030	Screw
7	1481.0008.020	Spring type straight pin
8	7991.1008.025	Screw
9	000.20.20.121	Cross grip
10	000.20.10.121	Handle
11	0912.1006.025	Screw
12	900.58.00.200	Belt tensioner, complete
19	000.31.20.091	Pressure spring
20	900.01.20.200	Guide plate
21	7500.1006.012	Screw
22	900.10.00.200	Fan insert complete, European version
24	902.10.00.200	Fan insert complete, American version
33	000.70.10.087	V-belt
34	900.50.10.100	Belt guard
40	900.80.00.100	Additional weight, complete
41	900.80.21.105	Felt
42	0912.1012.050	Screw

ATTENTION: Please specify in inquiries and spare part orders always the serial numbers of your machines (→ Section 3.1)!

SPARE PARTS TRIO

ATTENTION: Please specify in inquiries and spare part orders always the serial numbers of your machines (→ Section 3.1)!

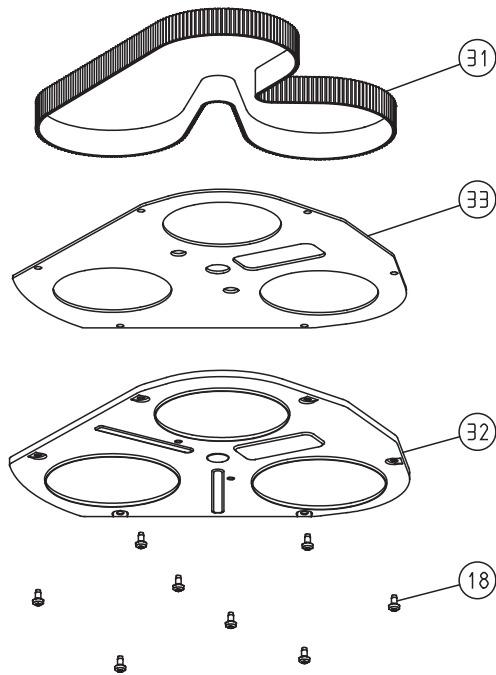
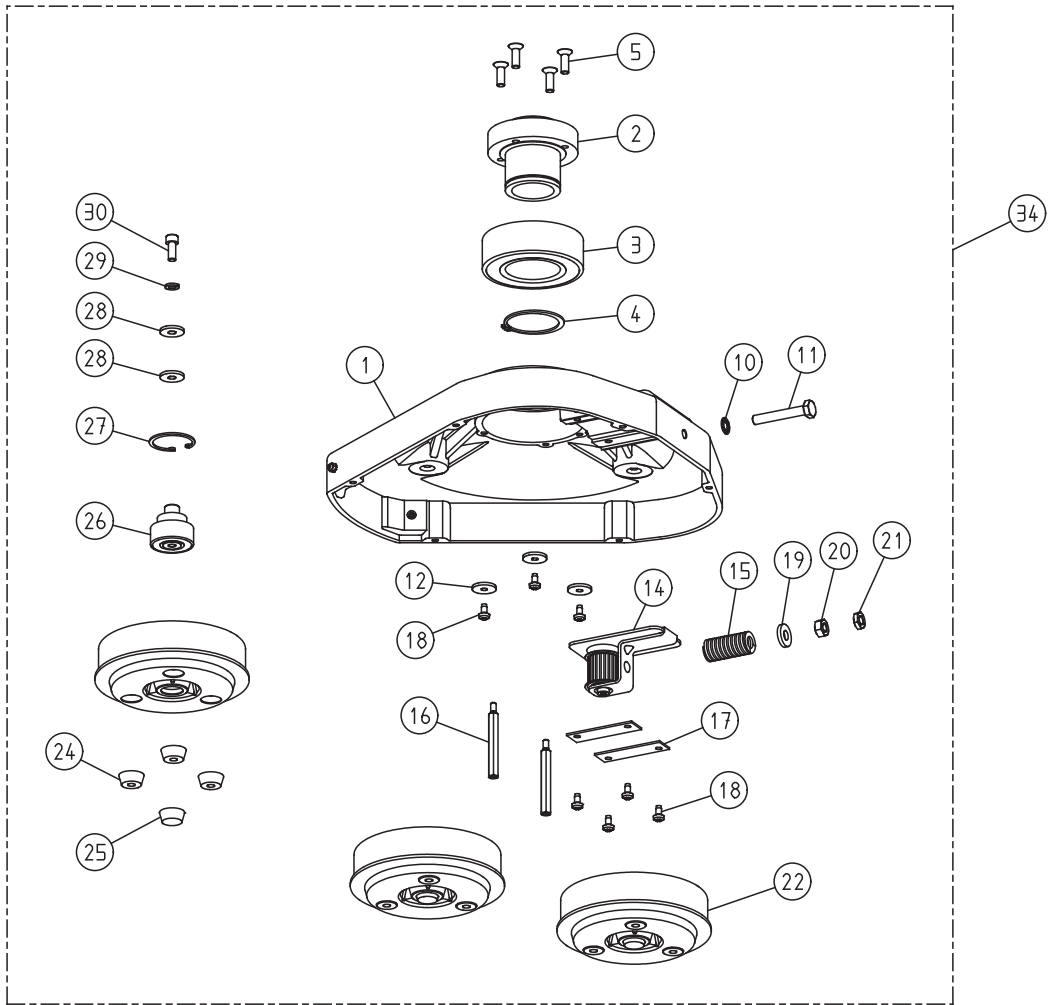

TRIO 4  
01.04.2014



## SPARE PARTS TRIO

Item	Part number	Description
1	900.07.10.200	Inner housing
2	900.07.20.100	Pick up
3	3212.0060.202	Ball bearing
4	0471.0060.000	Circlip
5	7991.1008.025	Screw
10	6797.1010.000	Washer
11	0933.1010.065	Screw
12	000.10.10.061	Washer
14	900.67.00.200	Tooth belt tensioner, complete
15	000.31.25.061	Pressure spring
16	900.07.42.205	Bolt
17	900.01.20.200	Guide plate
18	7500.1006.012	Screw
19	7349.1010.000	Washer
20	0934.1010.000	Nut
21	0439.1010.000	Nut
22	900.03.00.100	Pulley, complete
24	900.03.30.105	Rubber plug with hole
25	900.03.35.105	Rubber plug without hole
26	900.03.10.100	Axle pulley, complete
27	0472.0047.000	Circlip
28	000.10.10.081	Washer
29	0127.1008.000	Spring washer
30	0912.1008.020	Screw
31	000.75.28.152	Tooth belt
32	900.07.32.100	Cover complete
33	900.07.31.105	Sealing felt
34	900.07.00.100	Inner housing, complete

ATTENTION: Please specify in inquiries and spare part orders always the serial numbers of your machines (→ Section 3.1)!

SPARE PARTS TRIO

ATTENTION: Please specify in inquiries and spare part orders always the serial numbers of your machines (→ Section 3.1)!

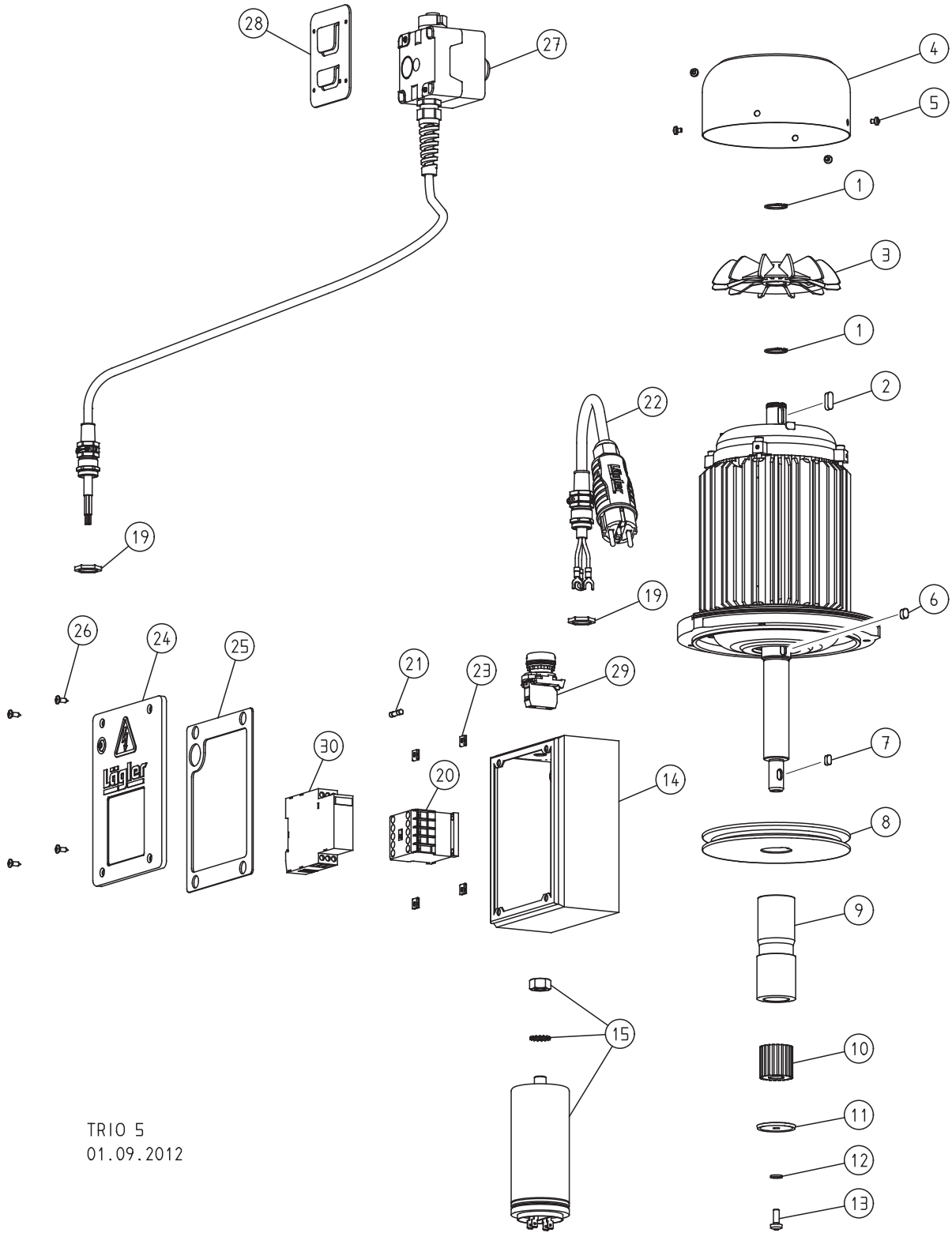

TRIO 5  
01.09.2012

## SPARE PARTS TRIO

Item	Part number	Description
	900.65.00.100	Motor, 230 V / 50 CPS / 1.8 kW
	901.65.00.100	Motor, 230 V / 60 CPS / 1.8 kW
	902.65.00.100	Motor, 220 V / 60 CPS / 1.8 kW, USA
	905.65.00.100	Motor, 400 V / 50 CPS / 2.2 kW, three-phase current
1	0471.0020.000	Circlip
2	6885.0606.018	Parallel key
3	900.65.08.100	Fan blade
4	900.65.09.100	Fan cover
5	7985.1004.805	Screw
6	6885.0606.010	Parallel key
7	6885.0505.010	Parallel key
8	900.65.06.100	Motor pulley
9	900.65.43.200	Spacer sleeve
10	900.65.41.105	Pinion
11	900.65.42.100	Washer
12	0127.1006.000	Spring washer
13	7985.1006.816	Screw
14	900.65.40.200	Switch box
15	000.65.10.041	Running capacitor 40 $\mu$ F
19	000.68.60.207	Nut (from year of manufacture 2008)
	000.68.60.163	Nut (up to year of manufacture 2007)
20	000.65.20.012	Contacto
	000.65.20.015	Contacto for three-phase AC motor
21	000.65.80.061	Fuse, 6.3 A
22	100.65.75.100	Motor cable 3 x 2.5 mm <sup>2</sup> (from year of manufacture 2008)
	000.65.43.251	Motor cable 3 x 2.5 mm <sup>2</sup> (up to year of manufacture 2007)
	102.65.75.100	Motor cable 3 x 2.5 mm <sup>2</sup> , USA (from year of manufacture 2008)
	000.65.43.257	Motor cable 3 x 2.5 mm <sup>2</sup> , USA (up to year of manufacture 2007)
	105.65.75.100	Motor cable 5 x 1.5 mm <sup>2</sup> for three-phase AC motor (from year of manufacture 2008)
	000.65.45.151	Motor cable 5 x 1.5 mm <sup>2</sup> for three-phase AC motor (up to year of manufacture 2007)
23	000.50.10.109	Clip nut
24	900.65.47.100	Cover with seal
25	465.65.48.105	Cover seal
26	7983.1042.013	Screw
27	900.65.60.200	Switch, complete (from year of manufacture 2008)
	900.65.60.100	Switch, complete (up to year of manufacture 2007)
28	900.65.55.200	Bracket
29	000.65.25.020	Lamp red for three-phase AC motor
30	000.65.20.220	Relay for three-phase AC motor

ATTENTION: Please specify in inquiries and spare part orders always the serial numbers of your machines (→ Section 3.1)!

SPARE PARTS TRIO

ATTENTION: Please specify in inquiries and spare part orders always the serial numbers of your machines (→ Section 3.1)!

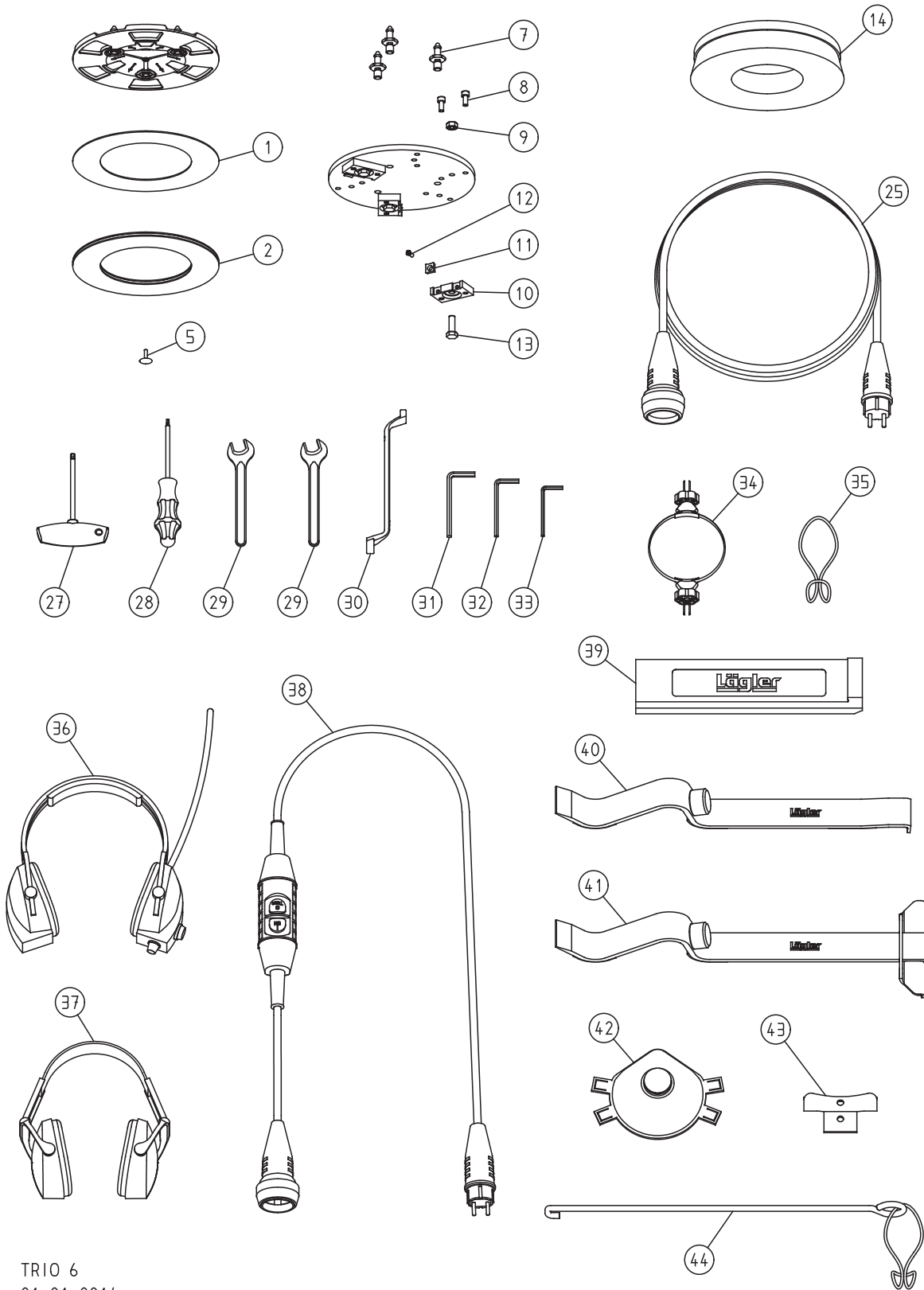

TRIO 6  
01.01.2014

## SPARE PARTS TRIO

Item	Part number	Description
	900.02.10.200	Sanding plate, complete
1	900.02.12.305	Velcro ring 200 mm
2	900.02.13.205	Velcro ring flexible 200/125 mm diameter
5	900.02.23.205	Plastic pin
	900.02.40.100	Milling disc TRIO, complete
7	900.02.42.105	Fastening bolt
8	0912.1006.014	Screw
9	0934.1008.000	Nut
10	900.02.43.100	Holder for indexable inserts
11	900.02.45.105	Carbide indexable insert (10 pieces per box)
12	900.02.47.105	Screw for indexable insert
13	900.02.49.105	Special screw
14	900.02.30.105	Brushing disc TRIO
25	000.65.53.251	Extension cable 3 x 2.5 mm <sup>2</sup> , 10 m long
	000.65.53.252	Extension cable 3 x 2.5 mm <sup>2</sup> , 20 m long
	000.65.55.151	Extension cable 5 x 1.5 mm <sup>2</sup> , 10 m long, for three-phase AC motor
27	000.91.40.301	Torx screwdriver T30
28	000.91.30.151	Torx screwdriver T15
29	000.95.11.171	Open mouth wrench 17 mm
30	000.95.21.103	Closed mouth wrench 10/13 mm
31	000.93.11.061	Hexagonal socket screw wrench 6 mm
32	000.93.11.051	Hexagonal socket screw wrench 5 mm
33	000.93.11.041	Hexagonal socket screw wrench 4 mm
34	000.01.40.112	MultiClip TRIO
35	00.000.41.002	Strain relief ring
36	000.01.10.011	Foldable earmuff type MUSIMUFF with FM radio
37	000.01.10.021	Foldable earmuff type POCKET
38	000.01.65.020	Safety switch PRCD-S (for German mains supply)
39	701.10.00.100	Impact tool
40	702.00.00.200	Parquet layer tool ZUGEISEN, small
41	703.00.00.200	Parquet layer tool ZUGEISEN, broad
42	000.01.20.010	Respiratory protection mask P3
43	900.70.56.100	Cable support bracket
44	100.20.26.100	Cable support, complete

ATTENTION: Please specify in inquiries and spare part orders always the serial numbers of your machines (→ Section 3.1)!

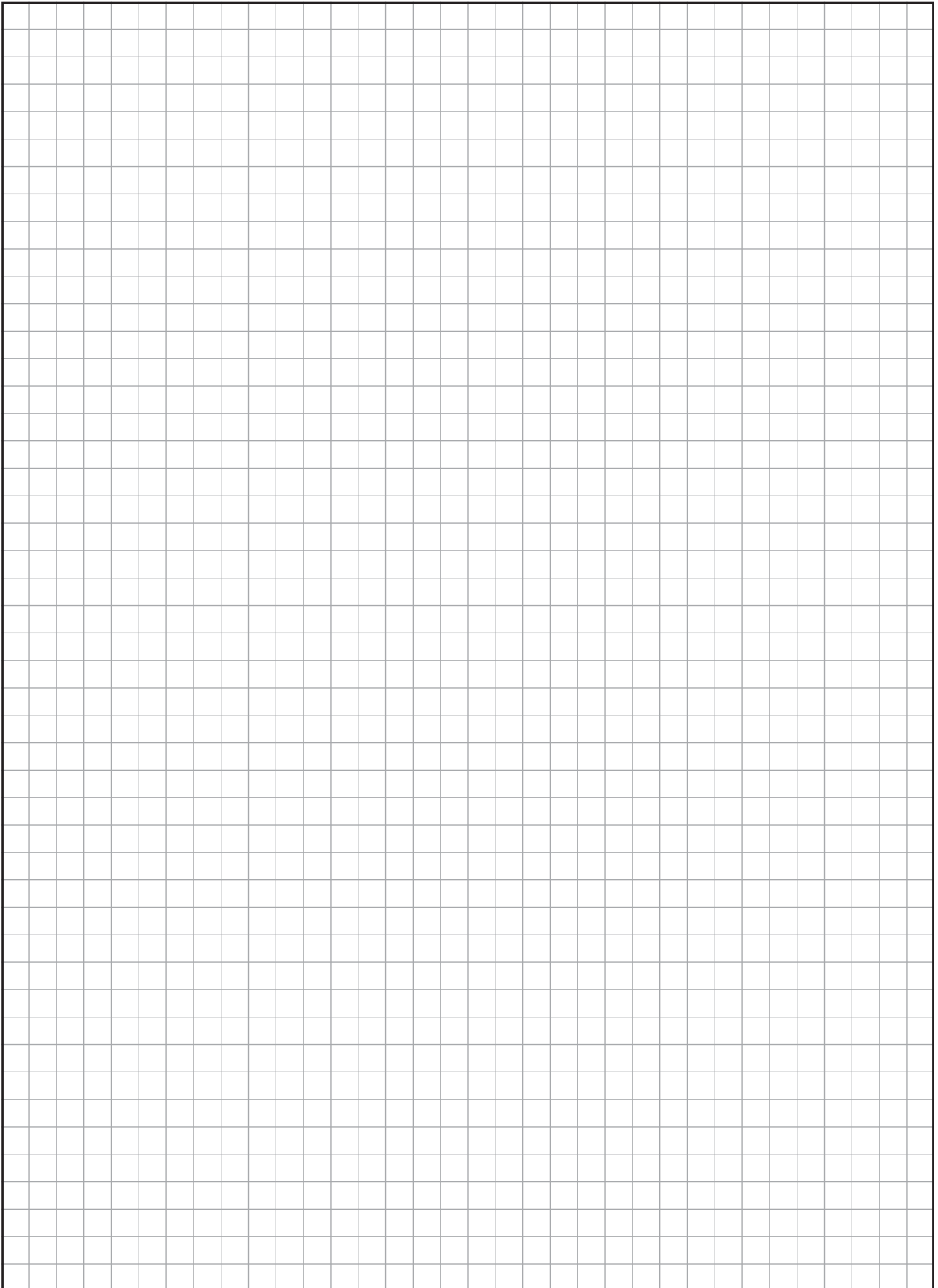

# Service passport

**Please enter the serial number and the year of manufacture of your machine (see type plate) on the rear side of these operating instructions! Otherwise the service passport will not be valid!**

This service passport is a document. Make sure that all the tests and maintenance work carried out on the machine are confirmed by the servicing company here.

<p>Date of test and maintenance work: _____</p>          <p>Signature and company stamp</p>	<p>Date of test and maintenance work: _____</p>          <p>Signature and company stamp</p>	<p>Date of test and maintenance work: _____</p>          <p>Signature and company stamp</p>
<p>Date of test and maintenance work: _____</p>          <p>Signature and company stamp</p>	<p>Date of test and maintenance work: _____</p>          <p>Signature and company stamp</p>	<p>Date of test and maintenance work: _____</p>          <p>Signature and company stamp</p>
<p>Date of test and maintenance work: _____</p>          <p>Signature and company stamp</p>	<p>Date of test and maintenance work: _____</p>          <p>Signature and company stamp</p>	<p>Date of test and maintenance work: _____</p>          <p>Signature and company stamp</p>
<p>Date of test and maintenance work: _____</p>          <p>Signature and company stamp</p>	<p>Date of test and maintenance work: _____</p>          <p>Signature and company stamp</p>	<p>Date of test and maintenance work: _____</p>          <p>Signature and company stamp</p>
<p>Date of test and maintenance work: _____</p>          <p>Signature and company stamp</p>	<p>Date of test and maintenance work: _____</p>          <p>Signature and company stamp</p>	<p>Date of test and maintenance work: _____</p>          <p>Signature and company stamp</p>

# EU Declaration of conformity for machines (EU Directive 2006/42/EC)

The manufacturer **Eugen Lägler GmbH, Kappelrain 2, D-74363 Güglingen-Frauenzimmern, Germany**  
 Tel.: 0049 - 7135 - 98 90-0 · Fax: 0049 - 7135 - 98 90-98  
 E-Mail: info@laegler.com · http://www.laegler.com

certified herewith, that the machine Generic denomination: **Floor sanding machine**  
 Function: **Dry sanding of wooden floors**  
 Model: **TRIO**  
 Serial number: **See type plate**  
 Commercial name: **Three disc sanding machine**

fulfils all the relevant provisions of the specified above European Directive.

The machine also fulfils all the relevant provisions of the European Directive  
**Electromagnetic compatibility (2004/108/EG).**

**The following harmonized standards have been applied:**

**DIN EN ISO 12100:** Safety of machinery - General principles for design - Risk assessment and risk reduction

**DIN EN 60204-1:** Safety of machinery - Electrical equipment of machines - Part 1

**DIN EN 55014-1:** Electromagnetic compatibility - Requirements for household appliances, electric tools and similar apparatus - Part 1

**DIN EN 55014-2:** Electromagnetic compatibility - Requirements for household appliances, electric tools and similar apparatus - Part 2

**DIN EN 61000-3-2:** Electromagnetic compatibility (EMC) - Part 3-2: Limits

**DIN EN 61000-3-3:** Electromagnetic compatibility (EMC) - Part 3-3: Limits

Güglingen-Frauenzimmern, April 1, 2015

*Volker Wörner*

Volker Wörner, Development Department  
 Person Responsible for Documents  
 Eugen Lägler GmbH, Kappelrain 2  
 D-74363 Güglingen-Frauenzimmern  
 Germany

**TRIO**

**Serial number:**

**Year of manufacture:**

\_\_\_\_\_

\_\_\_\_\_

**Lägler**  

[www.laegler.com](http://www.laegler.com)