



English / Englisch

Operating Instructions

Translation of original operating instructions
for the edge-, stair- and corner-sanding machine

ELAN

Lägler
www.laegler.com





CONTENTS

1	Introduction.....	5
1.1	Features of the machine	5
1.2	Description of the machine	5
1.3	Intended use of the machine.....	5
1.4	Protective devices.....	6
1.5	Machine configuration.....	6
1.5.1	Basic equipment.....	6
1.5.2	Optional equipment.....	6
1.5.3	Wearing parts and safety-related parts	7
2	Hazard warnings and safety instructions	8
2.1	Hazard warnings.....	8
2.2	General safety instructions	12
3	Technical data	14
3.1	Data on type plate	14
3.2	Machine data	15
4	Commissioning	17
4.1	Preparing the machine.....	17
4.2	Connecting the power cable	18
4.3	Switching on the machine	19
4.4	Switching off the machine.....	20
5	Working with the ELAN	21
5.1	General application tips.....	21
5.2	Replacing the sanding disc	22
5.2.1	Replacing the Velcro sanding disc.....	22
5.2.2	Replacing the conventional sanding disc.....	23
5.3	Replacing the sanding plate covering.....	23
5.4	Replacing the attachment.....	24
5.5	Emptying the dust bag.....	26
6	Transport and storage.....	28
7	Maintenance work and replacement of wearing parts	29
7.1	Cleaning and care.....	30
7.2	Tensioning the V-belt.....	31
7.3	Replacing the V-belt.....	32
7.3.1	Removing the V-belt.....	32
7.3.2	Installing the V-belt.....	32
7.4	Replacing the attachment pulley	33
7.5	Replacing the motor pulley.....	34
7.6	Replacing the carbon brushes	35
7.7	Checking the dust suction system	37
7.8	Adjusting the guide rollers	38
7.9	Replacing the wheels and the guide rollers	41
7.9.1	Replacing the wheels	41
7.9.2	Replacing the guide rollers	41
7.10	Replacing the wall-protecting roller	42

CONTENTS

8	Regular inspection and maintenance work in accordance with accident prevention regulations	43
9	Causes of faults	45
9.1	The machine does not run or has switched off automatically.....	45
9.2	The machine attempts to start up but is not able to do so.....	46
9.3	The machine runs but has no or very little sanding power capacity.....	46
9.4	The machine vibrates intensely and runs noisily.....	47
9.5	The machine runs but creates a great deal of dust.....	47
9.6	Sanding problems (waves, strips, grooves).....	48
10	Circuit diagrams.....	50
11	Spare parts ELAN	52
12	Service passport	59
13	EC Declaration of conformity for machines (EC Directive 2006/42/EC)	60

Safety notes used in this operating instructions and their meaning:

 <u>WARNING!</u>	Death, severe physical injury or significant property damage can occur if the corresponding cautionary measures are not taken!
 <u>CAUTION!</u>	Moderate to light physical injury or property damage can occur if the corresponding cautionary measures are not taken!
<u>ATTENTION!</u>	An undesired event can occur if the corresponding instructions are not followed!

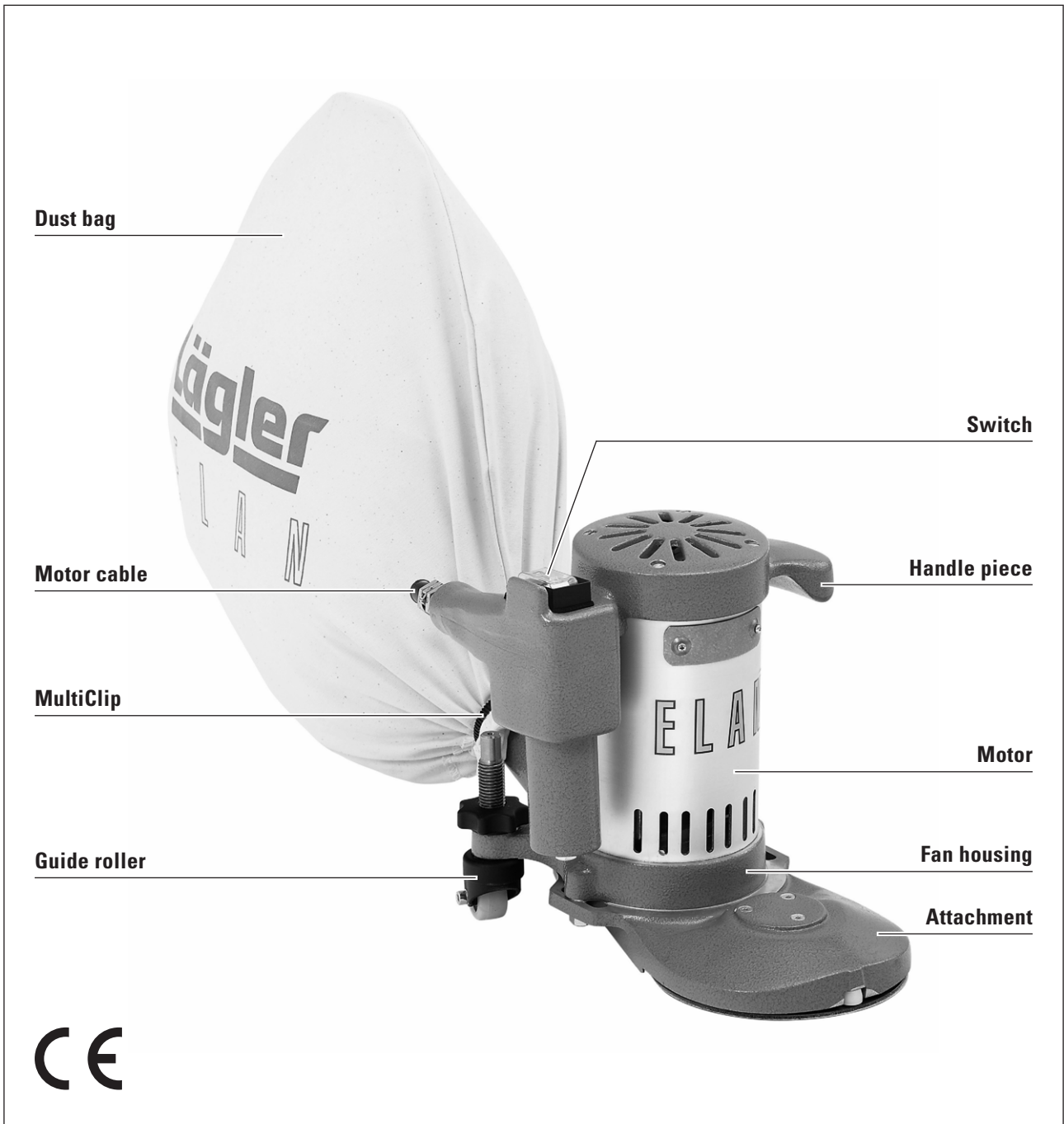

Fig. 1 Main features of the edge-, stair- and corner-sanding machine ELAN

Introduction

1.1 FEATURES OF THE MACHINE

In figure 1, we have indicated the most important components of the ELAN. Take your time to become familiar with the machine.

1.2 DESCRIPTION OF THE MACHINE

The edge-, stair- and corner-sanding machine ELAN works with a sanding disc on which Velcro sanding discs can be fastened. Traditional sanding discs fastened with a tensioning screw can, of course, also be used. The work zone is protected by the attachment. The fan housing, on which the electric motor is mounted in vertical position, is located on the attachment. A motor power supply cable is used to connect the machine to the power supply system. The motor switch with ON / OFF is located on the right side in the handle piece. The machine is moved by means of two guide rollers at the rear side of the machine. The handles are located on top of the motor. The suction muff, to which the dust bag clamp and the dust bag are attached, is located underneath the handles.

For the ELAN are three different attachments available (part numbers in *Section 11, Spare parts ELAN*):

- short attachment for sanding edges and stairs
- long attachment for sanding edges and under radiators, cabinets, shelves and the like
- corner attachment for sanding in corners

1.3 INTENDED USE OF THE MACHINE

The edge-, stair- and corner-sanding machine ELAN is suitable for the dry sanding of wooden floors, cork floors and wooden stairs in the professional and rental business sectors.

Any other form of use is not permitted without the approval of the manufacturer!

You have purchased a high-quality product from LÄGLER®. We wish you a great deal of success with your ELAN. All LÄGLER® products are subjected to a thorough inspection before leaving the factory.

Read these operating instructions completely before working with the ELAN for the first time! These operating instructions include important information on occupational safety and will provide you with answers to many questions so that you can work with the machine safely and without any problems. If you cannot find a specific subject in these operating instructions, please read the LÄGLER® application technique manual "Sanding of wooden floors" (<http://www.laegler.com>) or contact our service department, your retailer or your importer.



WARNING!

RISK OF DEATH from electrical shock:

The machine may never be used for wet processing operations of any kind!

INTRODUCTION

1.4 PROTECTIVE DEVICES

The following parts of the machine are protective devices and thus must always be kept in perfect condition:

attachment	= protection against sanding disc, protection against V-belt
attachment cover	= dust protection, protection against sanding disc, protection against V-belt
handle, motor housing	= protection against current-carrying parts

1.5 MACHINE CONFIGURATION

1.5.1 BASIC EQUIPMENT

- 1 machine ready for operation
- 1 operating instructions
- 1 dust bag
- 1 dust bag clamp
- 1 MultiClip for fastening the dust bag
- 1 extension cable 3 x 1.5 mm² (3 x 0.0023 sq. in.),
length 10 m (394")
- 1 closed mouth wrench, size 10 mm and size 13 mm
- 1 cotton bag
- 1 Velcro disc, diameter 150 mm (5.9")
- 1 felt disc, diameter 150 mm (5.9")
- 1 respiratory protective mask, filter class P3

1.5.2 OPTIONAL EQUIPMENT

- long attachment
- corner attachment
- foldable earmuff
- safety switch for fault current PRCD-S (for German mains supply)

NOTE:

You will find the corresponding part numbers for the optional equipment and wearing parts in *Section 11, Spare parts ELAN*.

1.5.3 WEARING PARTS AND SAFETY-RELATED PARTS

Check the condition of the wearing parts and safety-related parts mentioned below at regular intervals in order to be able to work safely and optimally at all times.

Replace the following parts in case of wear and/or damage:

- extension cable
- motor cable
- switch
- felt disc
- Velcro disc on sanding plate
- V-belt
- motor pulley
- sanding plate, complete
- sanding disc axle
- dust bag
- MultiClip
- guide roller
- paper tensioning disc
- hexagonal nut for paper tension
- carbon brushes

Hazard warnings and safety instructions



WARNING!

RISK OF DEATH, RISK OF INJURY, RISK OF FIRE:

- **Be certain to read the hazard warnings and safety instructions before using the machine!**
- **Instruct your co-workers and colleagues accordingly! Otherwise these persons could be exposed to danger or injured!**
- **Keep these hazard warnings and safety instructions in a safe place!**
- **Observe the applicable regulations and legal requirements in your country!**

2.1 HAZARD WARNINGS



WARNING!

RISK OF DEATH from suffocation and RISK OF INJURY:

- **Never** wrap the power cable around your neck or other parts of the body!

RISK OF DEATH from electrical shock:

- The machine may **never** be used for wet processing operations of any kind!
- Do not expose the machine to rain! Do not use the machine in moist or wet environments!
- **Never** connect the machine to hazardous electrical power sources! Only use safety sockets!
- To protect yourself and the machine against faults in the mains supply use a safety switch (for German mains supply → part number in *Section 11, Spare parts ELAN*)!
Observe the applicable regulations and legal requirements in your country!
- All extensive maintenance work, especially on the electrical equipment, **must** be conducted by a qualified expert for safety reasons!
- The machine **must** be switched off and the power plug **must** be removed from the socket during all maintenance work and all work on the electrical equipment!
- Avoid body contact with grounded parts, e.g. pipes, radiators, ovens, refrigerators!
- The quality of the motor cable and the power cables **must** match the quality of the original LÄGLER® cables!
- The motor cable and the power cables must be protected from mechanical and electrical damages in the workplace!
- Do not carry or pull by the machine by the cable! Do not pull on the cable to remove the plug from the socket! Protect the cables against heat, oil and sharp edges!

**WARNING!****RISK OF DEATH and RISK OF PROPERTY DAMAGE from unsecured load:**

- When transported in a car or the like, the machines and all parts must be secured against sliding!

RISK OF EXPLOSION due to sparks while sanding or a high dust concentration in the air:

- Do not use the machine near
 - sources of fires,
 - flammable liquids or gases,
 - potentially explosive areas!
- Do not smoke in a dusty environment, e.g. while sanding, emptying the dust bag or cleaning the machine!

RISK OF FIRE from sparks while sanding or from spontaneous combustion:

- Prior to sanding a nailed or screwed floor all nails or screws must be countersunk deeply enough so that they cannot be sanded:
 - Countersink the nails for example with a hammer and a punch!
 - Tighten the screws!
- There is a high risk of fire when sanding woods with a large amount of resin, oiled or waxed floors or metal! Therefore, the machine must **always** be cleaned carefully **directly** after sanding! **Be certain** to note the warning notices of the manufacturers of paint, oil and wax!
- Cloths, pads, et cetera which have been immersed in oil or wax can spontaneously combust! **Be certain** to note the warning notices of the manufacturers of paint, oil and wax!
- The dust bag must **always** be removed from the machine **directly** after sanding and emptied into a **non-combustible** container outdoors! Cover this container with a **non-combustible** cover and **be certain** to store it and the dust bag **outdoors** in **non-combustible** environment (→ *Section 5.5, Emptying the dust bag*)!
- Always transport and store used dust bags in **closed** and **non-combustible** containers!
- Always transport and store the machine **without** dust bag!

**WARNING!****RISK OF FIRE from the overheating of the cables:**

- Only cables with **three** wires and wire cross-sections of **at least** 1.5 mm² (0.0023 sq. in.) may be used as motor cables and power cables!
- The **maximum** cable length in order to connect the machine to the mains supply must not exceed 20 m (790")!

HEALTH RISK caused by dust:

- Make sure that the dust bag is properly fastened to the machine!
- Do not use damaged, washed or repaired dust bags!
- Do not work with an overfilled dust bag (→ *Section 5.5, Emptying the dust bag!*)
- If the machine is operated **correctly**, the mandatory dust emission values will not be exceeded! Empty the dust bag **outdoors!** At the same time a respiratory protective mask (at least filter class P2) **must** be worn!
- A respiratory protective mask (at least filter class P2) must be worn when conducting all work that creates dust, e.g. emptying the dust bag or cleaning of the machine!

**CAUTION!**

RISK OF INJURY and RISK OF PROPERTY DAMAGE from rotating tools and parts of the machine:

- For all operating conditions of the machine only **one** operator is required! As a consequence, for safety reasons only **one person** must be in the working area while operating the machine!
- Before switching on the machine, make sure that all tools and adjustment tools have been removed from the machine!
- The machine **may not be started** if the sanding plate is on the floor! Therefore, tip the machine backwards slightly to start the machine (→ *Section 4.3, Switching on the machine*)!
- **Never** leave the operational machine unattended!
- Do not reach into rotating tools or parts of the machine!
- Do not wear any long articles of clothing or jewelry! These could be caught by moving parts!

RISK OF INJURY and RISK OF PROPERTY DAMAGE from unintentional starting of the machine:

- The power plug **must always** be removed from the socket when the machine is switched off!
- Make sure that ON/OFF switch is not set to ON when connecting the machine to the mains supply!

RISK OF INJURY and RISK OF PROPERTY DAMAGE from the rolling away, tipping or falling of the machine:

- The machine must be secured against rolling away, tipping or falling when not in use!
- **Always** ensure that the machine is standing securely!

RISK OF INJURY and RISK OF PROPERTY DAMAGE from unsuitable parts:

- Only use tools, accessories and spare parts from LÄGLER® for the ELAN (→ *Section 11, Spare parts ELAN*)!
Warranty claims for foreign parts or damage caused thereby cannot be accepted!

**CAUTION!****HEALTH RISK caused by noise:**

- Use hearing protection when conducting work that produces noise! Observe the applicable regulations and legal requirements in your country!

RISK OF PROPERTY DAMAGE:

- Never use any cleaning products which contain solvents!
- Do not store the unused machine with sanding media on the sanding plate! Otherwise the sanding media can cause scratches on the ground!
- Never conduct a maintenance or a replacement of wearing parts on the newly sanded wooden floor! Thus, you will avoid scratches or other damage to the floor!
- Improper transport will result in damage to the machine!

2.2 GENERAL SAFETY INSTRUCTIONS

- **Check your machines for damage!**

Before using the machines, you must inspect the safety devices carefully to ensure that they are working perfectly and as intended.

Check whether the moving parts are working properly, that they are not sticking, that no parts are broken, whether all parts are in perfect condition and installed properly and whether all other conditions which could influence the operation of the machine are in order.

Damaged safety devices and parts must be properly repaired or replaced by an authorized service shop insofar as nothing to the contrary is indicated in the operating instructions.

Regularly inspect the motor cable and have it replaced by a qualified electrician if it is damaged. Inspect the extension cable regularly and replace it if it is damaged (part numbers in *Section 11, Spare parts ELAN*).

Damaged electrical components must be replaced by a qualified electrician (part numbers in *Section 11, Spare parts ELAN*).

Do not use the machine if it cannot be switched on and/or switched off by using its switch.

- **Maintain your machines with care!**
 - Keep your machines clean so that you can work better and more safely.
 - Follow the maintenance guidelines and the instructions for replacing tools.
 - Keep the handles dry and free of oil and grease.

- **Provide good illumination in the workplace!**

Well lit construction sites reduce the risk of injury and allow you to better evaluate the quality of your work.

- **Keep your work area tidy!**

Untidy work areas create a risk of accidents.

- **Use the proper machines!**

Do not use low-performance machines or additional devices for heavy jobs. Do not use the machine for purposes and work that it is not intended for.

- **Do not overload the machines!**

It works better and more safely in the power range noted.

- **Do not bend too far over the machine!**

Avoid unnatural postures. Make sure that you stay in a stable position and keep your balance at all times.

- **Be attentive!**

Pay attention to your work. Work carefully and do not use the machines if you are not concentrating.

- **Store your machines safely!**

Store your unused machines in a dry, closed location out of the reach of children!

Technical data



Fig. 2 Type plate on motor housing.

3.1 DATA ON TYPE PLATE

ATTENTION!

In order to receive the correct spare parts from us, please specify in inquiries and spare part orders always the serial numbers of your machines!

The type plate of ELAN is located on the motor housing (fig. 2).

The following technical data are specified on the type plate (fig. 3):

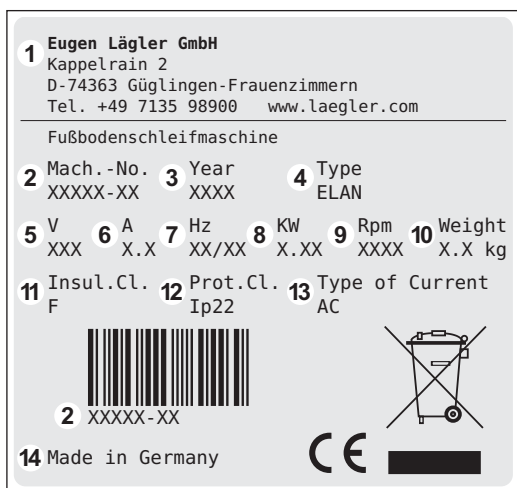

Fig. 3 Data on type plate.

- 1 Manufacturer
- 2 Serial number of machine (Mach.-No.)
- 3 Year of manufacture (Year)
- 4 Machine name (Type)
- 5 Required mains voltage in volt (V)
- 6 Current consumption in ampere (A)
- 7 Motor frequency in CPS (Hz)
- 8 Motor power in kilowatt (KW)
- 9 Motor speed in 1/min (Rpm)
- 10 Weight of machine (Weight)
- 11 Insulation class (Insul. Cl.)
- 12 Protection class (Prot. Cl.)
- 13 Type of current
- 14 Country of manufacture

3.2 MACHINE DATA

Manufacturer	Eugen Lägler GmbH
Machine type	edge-sanding machine
Machine name	ELAN
Serial number	see type plate (fig. 2)
Year of manufacture	see type plate (fig. 2)

Motor type	universal motor	
Type of current	alternating current (AC)	
Voltage	230 V	110 V / 120 V
Frequency	50 / 60 Hz (CPS)	50 / 60 Hz (CPS)
Motor power	1.2 kW	1.05 kW
Necessary fuse protection of power supply system	at least 10 A	at least 15 A
Insulation class	F	
Protection class	IP 22	
Safety devices	no-voltage release, thermal overload protection in motor	

Sanding disc diameter - short and long attachment - corner attachment	150 mm (approx. 5.9") 75 mm (approx. 3")
Sanding disc speed - short and long attachment - corner attachment	approx. 4000 1/min (rpm) approx. 8000 1/min (rpm)
Length - short attachment - long attachment - corner attachment	110 mm (approx. 4.3") 310 mm (approx. 12.2") 130 mm (approx. 5.1")
Height - short and long attachment - corner attachment	42 mm (approx. 1.7") 45 mm (approx. 1.8")

TECHNICAL DATA

NOTE on noise emission:

The values indicated are emission values and must not represent safe workplace values as well.

Although a correlation exists between emission levels and immission levels, it is not always possible to determine whether additional precautionary measures are required.

Factors that can have an effect on the immission level existing at the workplace include the duration of the effects, the characteristics of the work area and other sources of noise, e.g. the number of machines and processing operations in the vicinity. The permissible workplace values may also vary from country to country.

This information, however, is intended to enable the user to better estimate the dangers and risks.

Overall length of the machine without dust bag	
- with short attachment	380 mm (approx. 15")
- with long attachment	580 mm (approx. 22.8")
- with corner attachment	400 mm (approx. 15.7")
Overall height of the machine without dust bag	255 mm (approx. 10")
Overall width of the machine	230 mm (approx. 9.1")
Overall weight of the machine	8 kg (approx. 17.6 lbs)

Dust emissions at workplace	< 2 mg/m ³ (0.024 gr./cu.yd.)
Workplace-related noise emission values	89 dB(A)
Measurement uncertainty constant of the noise emission values	4 dB(A)
Vibration total value a_{hv} measured at the handle	< 2.5 m/s ²

Commissioning

This section describes how to put the ELAN into service on site. In order to prevent damage and malfunctions, you should proceed in the order of steps mentioned below. Before starting to work with the machine, you must be properly instructed by your dealer.

4.1 PREPARING THE MACHINE

ATTENTION!

Please note that the packaging serves as a transport container for the machine, accessories and the sanding medium! Furthermore, the machine can be sent back safely in the original packaging without risk should there be any problems!

- 1 Unpack the machine carefully. Dispose of the packing materials according to environmental regulations or keep them in order to be able to ship the machine in case of any problems.
- 2 Install the dust bag clamp in the drilled hole at the end of the suction muff (fig. 4).
- 3 Place the MultiClip over the opening of the dust bag (fig. 5).
- 4 Place the opening of the dust bag over the dust bag clamp and the suction muff (fig. 6).
- 5 Tying up the dust bag with the cord (fig. 7).
- 6 Make sure the nut of the MultiClip is facing upwards and tighten down the nut by hand. Make sure the dust bag is not lying in folds underneath the MultiClip (fig. 8).

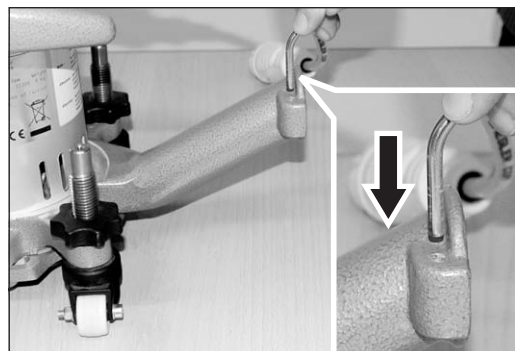

Fig. 4 Installation of the dust bag clamp.

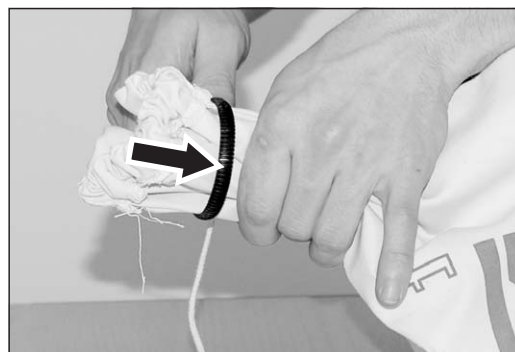

Fig. 5 Push the MultiClip over the dust bag.



Fig. 6 Place the dust bag over the clamp.



Fig. 7 Tying up the dust bag with the cord.



Fig. 8 Sealing the dust bag with the MultiClip.

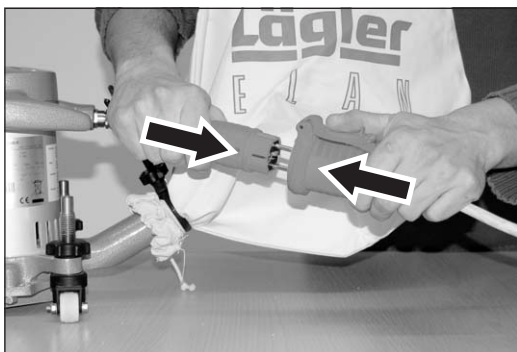

Fig. 9 Connect the motor cable to the extension cable.

4.2 CONNECTING THE POWER CABLE



WARNING!

RISK OF DEATH from electrical shock:

- **Never** connect the machine on hazardous electrical power sources! **Only use safety sockets!**
- To protect yourself and the machine against faults in the mains supply use a safety switch PRCD (for German mains supply → part number in *Section 11, Spare parts ELAN*)!
- Observe the applicable regulations and legal requirements in your country!

RISK OF FIRE from the overheating of the cable:

- Only cables with three wires and wire cross-section of at least 1.5 mm² (0.0023 sq. in.) may be used as motor cables and power cables!
- The maximum cable length in order to connect the machine to the mains supply must not exceed 20 m (790")!

- 1 Insert the plug of the motor cable in the coupling of the extension cable (fig. 9).
- 2 Insert the extension cable in a suitably protected socket with ground contacts.

4.3 SWITCHING ON THE MACHINE

**CAUTION!**

RISK OF INJURY and RISK OF PROPERTY DAMAGE from rotating parts of the machine:

- **Always tip the machine backwards slightly (fig. 10) before switching on the machine so that the sanding disc is raised off the floor!**
- **Never allow the machine to run unattended!**

- 1 **Tip the machine backwards slightly (fig. 10)!**
- 2 Push the switch to "I" (fig. 11). The switch button will snap into the place and the motor will be started.
- 3 Tip the machine forward and begin sanding (→ *Section 5, Working with the ELAN*).



Fig. 10 **Always tip the machine backwards slightly before switching on or switching off the machine.**

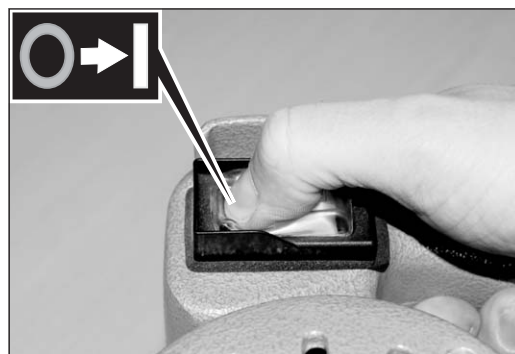

Fig. 11 **Push the switch to "I" and the motor will be started.**

**CAUTION!**

RISK OF PROPERTY DAMAGE:

If the switch button does not snap into switch position "I", do not continue sanding! Otherwise the motor can be permanently damaged!

Remedy the following causes for the malfunction:

- **The electrical network has undervoltage! Use a transformer if necessary.**
- **The extension cable is too long (longer than 20 m (790")) or the cable cross-sections of the extension cable are smaller than 1.5 mm² (0.0023 sq. in.)!**
- **The carbon brushes of the motor have reached their wear limit and must be replaced (→ *Section 7.6, Replacing the carbon brushes*).**
- **The switch is defective! It must be replaced by a qualified electrician (→ *Section 10, Circuit diagrams*)!**



Fig. 12 Push the switch to "0" and the motor will be switched off.

4.4 SWITCHING OFF THE MACHINE



CAUTION!

RISK OF INJURY and RISK OF PROPERTY DAMAGE from rotating parts of the machine:

Always tip the machine backwards slightly (fig. 10) before switching off the machine so that the sanding disc is raised off the floor!

- 1 **Tip the machine backwards slightly (fig. 10)!**
- 2 Push the switch to "0" (fig. 12). The switch button will snap into the place and the motor will be switched off.
- 3 **Wait until the sanding plate comes to a complete stop before stand the machine back on the sanding plate!**



CAUTION!

RISK OF INJURY and RISK OF PROPERTY DAMAGE:

Always remove the power plug from the socket after you have switched off the machine!

ATTENTION!

Do not store unused machines with sanding media on the sanding plate! The sanding media can cause scratches on the ground!

Working with the ELAN

5.1 GENERAL APPLICATION TIPS



WARNING!

RISK OF DEATH from electrical shock:

The machine may never be used for wet processing operations of any kind!

ATTENTION!

- Bear in mind that the ELAN operates at very high cutting speeds! For this reason, there is a risk of burn marks for finer grit grades!

- Do not apply excessive pressure to the attachment while sanding!

Excessive pressure

- significantly worsen the sanding finish by causing deep scratches or burn marks on the floor,
- could cause the motor to switch off from overheating!

- Do not touch the switch button while sanding (fig. 13)! Otherwise the wear of the switch increases significantly!

The ELAN is a very versatile machine. The attachment can be changed in a matter of seconds (→ Section 5.4, *Replacing the attachment*). The ELAN is used for the dry sanding of edges, stairs and corners.

- Move the ELAN with **short** or **long attachment** in circular motions **clockwise** while sanding (fig. 14)!

Move the ELAN with **corner attachment** in circular motions **counterclockwise** while sanding (fig. 15)!

- Deep sanding marks due to the selection of a too coarse grit grade can be prevented by starting the first sanding operation with the finest grit grade possible.
- Prevent sanding marks made by previously used grit grade by adhering to the order of the sandpaper grit grade and never skip more than one grit grade.

NOTE:

For more information free of charge, please contact: within Germany

- Telephone: 0800 / 52 34 537

- Fax: 0800 / 48 66 353

within the USA

- Telephone: 800-848-6635

or

- Telephone: 0049 - 7135 - 98 90 - 0

- Fax: 0049 - 7135 - 98 90 - 98

- E-mail: info@laegler.com

- Internet: <http://www.laegler.com>

You will also find important and interesting application tips in the LÄGLER® application technique manual "Sanding of wooden floors" (<http://www.laegler.com>)!



Fig. 13 Guide the ELAN with both hands. **Do not touch the switch button while sanding!**

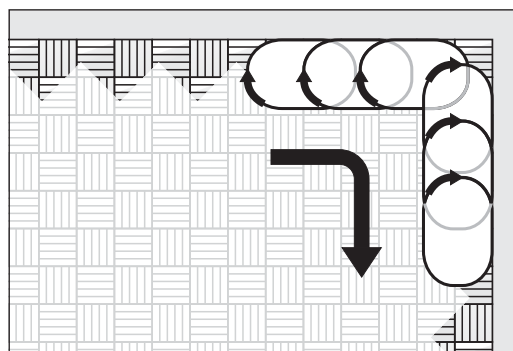

Fig. 14 ELAN with **short** or **long attachment**: Circular motions **clockwise**!

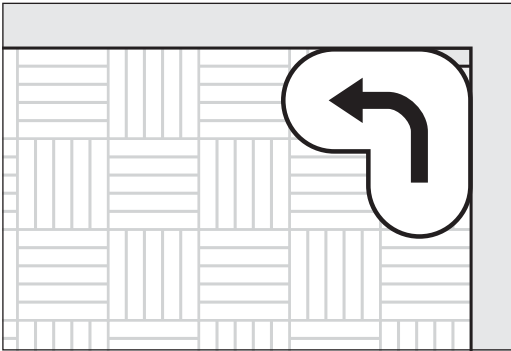

Fig. 15 ELAN with **corner attachment**:
Circular motions **counterclockwise!**

- After replacing the sanding disc, start working in poorly lit areas of the room in order to remove the initial aggressiveness of the sanding medium.
- Always vacuum the floor or stairs thoroughly **before the first** sanding operation **and after each additional one**.
- Clean the wheels of the machine regularly.

5.2 REPLACING THE SANDING DISC

ATTENTION!

- **Only use sanding discs with paper as the base! Do not use any sanding discs with thick bases such as fiber discs, cutting discs or similar materials! Otherwise the sanding plate will be damaged!**
- **Do not use any double sanding discs (with sanding grit on both sides)! Otherwise the Velcro coating on the sanding plate will be damaged!**
- **Always use only one sanding disc! Otherwise the sanding result will not be satisfactory and the dust suction system will not be fully operational!**
- **You will receive the best sanding finish and price/performance ratio with the Velcro sanding discs from LÄGLER®!**



Fig. 16 Simply pull off the Velcro sanding disc.

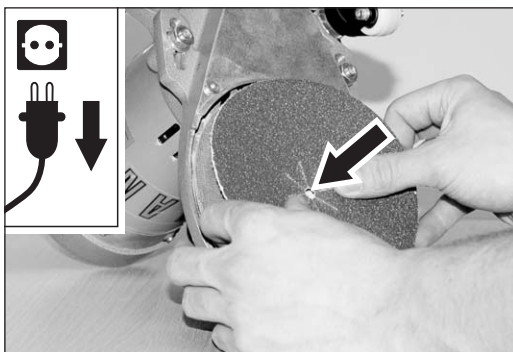

Fig. 17 Mount the new Velcro sanding disc in centered position and press down.

5.2.1 REPLACING THE VELCRO SANDING DISC

- 1 **Switch off the machine and pull the power plug out of the socket!**
- 2 Place the machine upside down carefully in order to prevent damage to the floor and machine.
- 3 Pull off the worn-out Velcro sanding disc from the sanding plate (fig. 16).
- 4 Place a new Velcro sanding disc on the sanding plate. The Velcro sanding disc must be seated in centered position on the sanding plate. A drilled hole in the center of the sanding disc and the sanding plate axle make this step easier (fig. 17).

5.2.2 REPLACING THE CONVENTIONAL SANDING DISC

- 1 **Switch off the machine and pull the power plug out of the socket!**
- 2 Place the machine upside down carefully in order to prevent damage to the floor and machine.
- 3 Use the closed mouth wrench to loosen the hexagonal nut of the paper tensioning device (fig. 18).
- 4 Rotate the hexagonal nut all the way out. Remove the paper tensioning disc and the sanding disc from the sanding plate and put these parts aside (fig. 19).
- 5 Place a new sanding disc on the sanding plate and press the paper tensioning disc onto the sanding plate axle.
- 6 Rotate the hexagonal nut onto the sanding plate axle. Make sure the sanding disc is fastened in centered position on the sanding plate.
- 7 Use the closed mouth wrench to tighten the hexagonal nut of the paper tensioning device (fig. 20).

ATTENTION!

Do not tighten the screw for attaching the sanding disc too tightly! The thread of the sanding plate could otherwise be damaged!

5.3 REPLACING THE SANDING PLATE COVERING

The ELAN is equipped with a factory-installed Velcro negative. Re-equipping to a felt covering is possible since the sanding plate coverings have been designed as self-adhesive versions. Traditional paper discs or Velcro sanding discs can be used on the Velcro covering.

The sanding plate covering must be replaced when worn-out or damaged.

- 1 **Switch off the machine and pull the power plug out of the socket!**

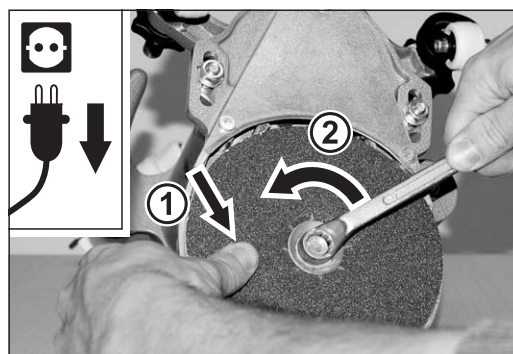

Fig. 18 Remove the conventional sanding disc by loosening the tensioning nut with the closed mouth wrench.

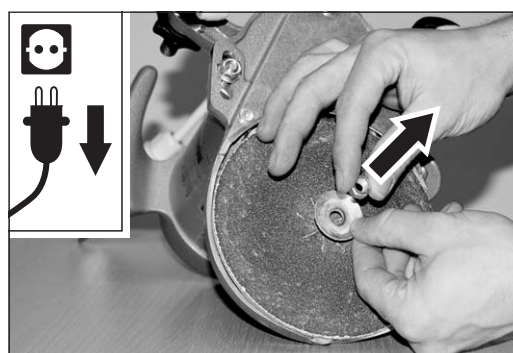

Fig. 19 Remove the nut and the paper tensioning disc from the sanding plate.

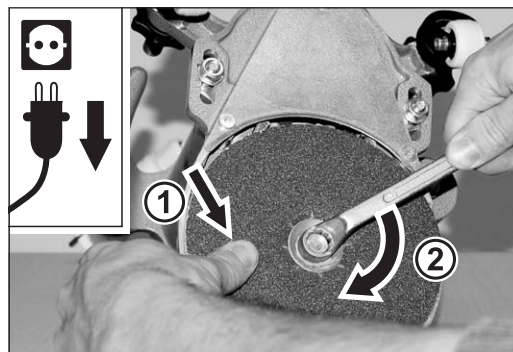

Fig. 20 Mount a new sanding disc and assemble again.



Fig. 21 After removing the sanding disc pull off the Velcro negative and clean the sanding plate.

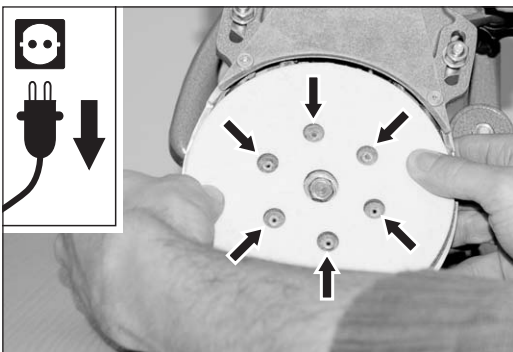

Fig. 22 Place the new sanding plate covering on the fastening rivets correctly lined up and press down over the entire surface and in the cone on the thread.

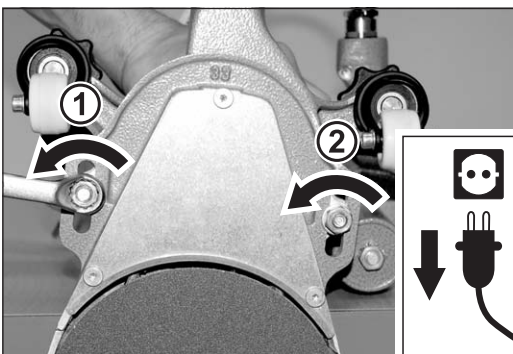

Fig. 23 Remove the two nuts and the washers with which the attachment is fastened.

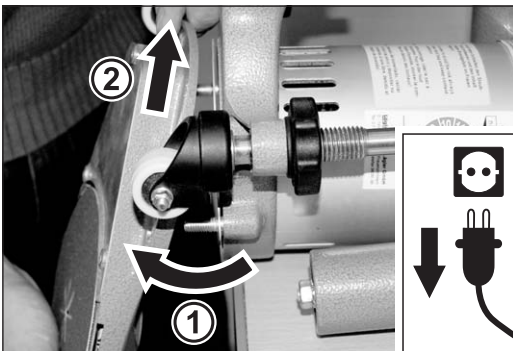

Fig. 24 Remove the attachment from the machine.

- 2 Place the machine upside down carefully in order to prevent damage to the floor and machine.
- 3 Remove the sanding disc and the old sanding plate covering (fig. 21).
- 4 Clean the steel sanding plate of all disc and adhesive residue.
- 5 Degrease the steel sanding plate using a thinner. **Observe the manufacturer's safety instructions!**
- 6 Stick the new sanding plate covering carefully onto the sanding plate and make sure the covering is seated in centered position and the drilled holes in the covering line up with the rivets of the sanding plate (fig. 22).
- 7 Depending on the sanding disc type you are now using, you must carry out the mounting procedure as described in *Section 5.2.1, Replacing the Velcro sanding disc* and *Section 5.2.2, Replacing the conventional sanding disc*.

5.4 REPLACING THE ATTACHMENT

For the ELAN are three different attachments available (part numbers in *Section 11, Spare parts ELAN*):

- short attachment for sanding edges and stairs
- long attachment for sanding edges and under radiators, cabinets, shelves and the like
- corner attachment for sanding in corners

Proceed as follows to replace the attachment:

- 1 **Switch off the machine and pull the power plug out of the socket!**
- 2 Lay the machine on its side or with the motor housing on a table. Avoid damages to the floor or table and the machine.
- 3 Use the closed mouth wrench to remove the two hexagonal nuts (wrench size 13 mm) and the washers which are used to fasten the attachment (fig. 23).
- 4 Remove the attachment from the machine (fig. 24).

- 5 Then place the other attachment on the machine by inserting the V-belt into the motor pulley first and then place the attachment on the machine (fig. 25).
- 6 Then screw the hexagonal nuts (wrench size 13 mm) onto the threaded studs. Make sure that washers are installed under the hexagonal nuts. **Do not tighten the nuts yet!**
- 7 Grab the ELAN at the suction muff and press the attachment forward with your thumb at the same time (fig. 26, 1). Make sure that the distances between the threaded studs in the long holes are equal on both sides (fig. 26, distance **A** = distance **B**).
- 8 With the attachment pushed forward, use the closed mouth wrench to tighten the two hexagonal nuts (wrench size 13 mm; fig. 26, 2 + 3).

ATTENTION!

Do not tighten the V-belt too much in order to prevent excessive wear of the V-belt and the pulleys!

- 9 Turn the sanding plate by hand (fig. 27). Look at the same time through the slots in the handle. The fan blade of the motor must rotate (fig. 28). Otherwise the points 5 to 9 must be repeated!
- 10 Check the machine setting (→ *Section 7.8, Adjusting the guide rollers*).

Check the belt tension again after running-in period of a few days and tighten the V-belt again if necessary!

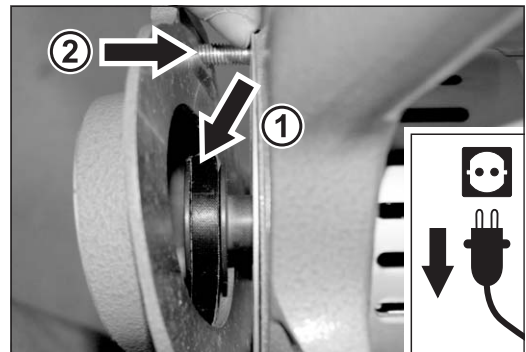

Fig. 25 The V-belt must be lying in the motor pulley.

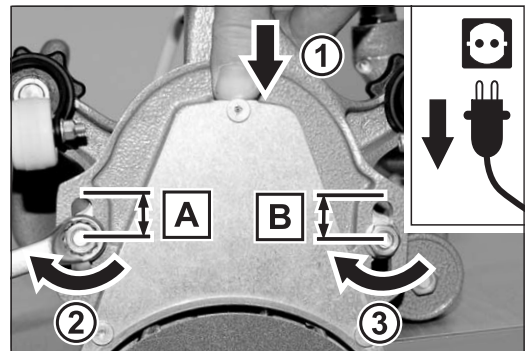

Fig. 26 Tighten the two nuts again while using your thumb to press the attachment forward in order to maintain the belt under tension. **A** and **B** should be equal.

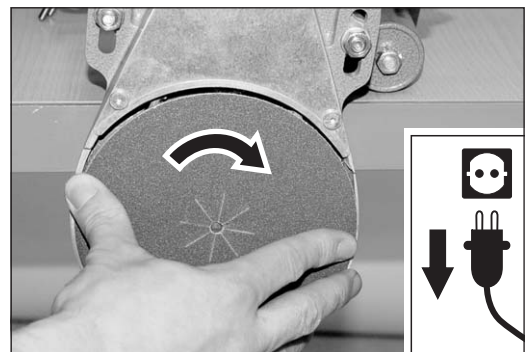

Fig. 27 While turning the sanding plate, ...

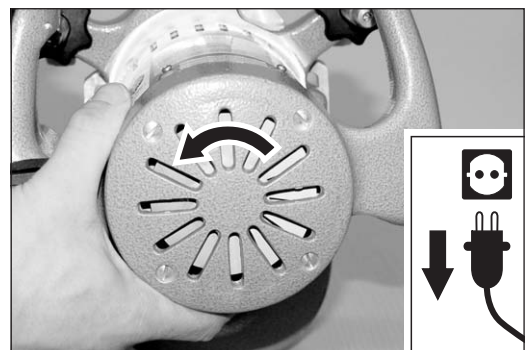

Fig. 28 ... the fan blade of the motor must rotate.

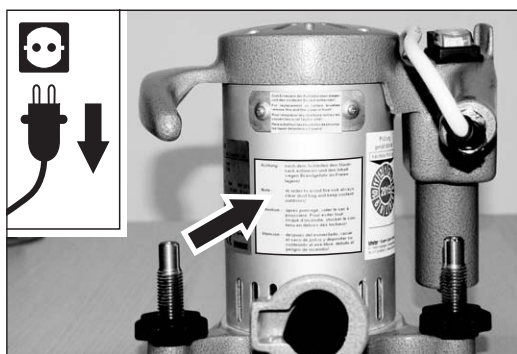

Fig. 29 Note the warning on the motor housing!

5.5 EMPTYING THE DUST BAG



WARNING!

RISK OF FIRE from the formation of sparks while sanding:

- **Note the warning on the motor housing (fig. 29)!**
- **The dust bag must always be removed from the machine directly after sanding and emptied into a non-combustible container outdoors!**
Cover this container with a non-combustible cover and be certain to store it and the dust bag outdoors in non-combustible environment!
- **Always transport and store used dust bags in closed and non-combustible containers!**

HEALTH RISK caused by dust:

In order to ensure that the dust values in the air do not exceed the prescribed threshold levels, please note:

- **The dust bag must be emptied when it is one-third full at the very latest in order to prevent a deterioration of the suction performance due to the lack of filtering surface area!**
- **Do not work with an overfilled dust bag!**
- **The dust bag must be emptied outdoors!**
- **When emptying the dust bag, wear a respiratory protective mask (at least filter class P2)!**
- **Do not wash, patch or repair the dust bag in any other manner!**
- **Damaged dust bags must be replaced with new ones!**

Proceed as follows to empty the dust bag:

- 1 Switch off the machine and pull the power plug out of the socket!**
- 2 Remove the plug of the motor cable from the extension cable coupler.**
- 3 Put on a respiratory mask (at least filter class P2)!**

- 4 Pick up the machine and shake the dust residue from the machine into the dust bag (fig. 30).
- 5 Undo the MultiClip fastener (fig. 31) and the cord of the dust bag (fig. 32).
- 6 Keep the opening of the dust bag closed and carefully pull it off from the pipe muff (fig. 33) and the clamp (fig. 34).
- 7 **Empty the dust bag into a non-combustible container outdoors! Cover this container with a non-combustible cover (RISK OF FIRE)!**
- 8 Attach the dust bag again (→ *Section 4.1, Preparing the machine*). **Wear the respiratory protective mask!**



Fig. 30 Before emptying, shake the dust residue into the dust bag.

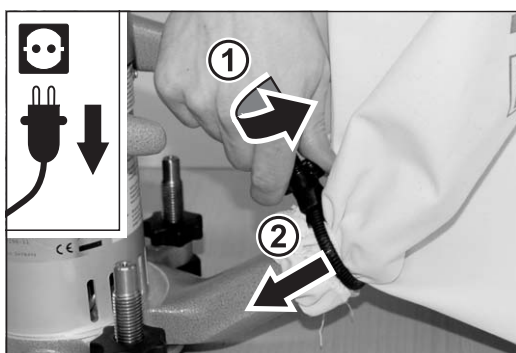

Fig. 31 Undo the MultiClip fastener of the dust bag.

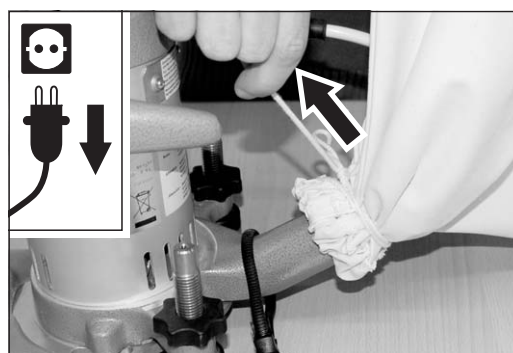

Fig. 32 Undo the cord of the dust bag.

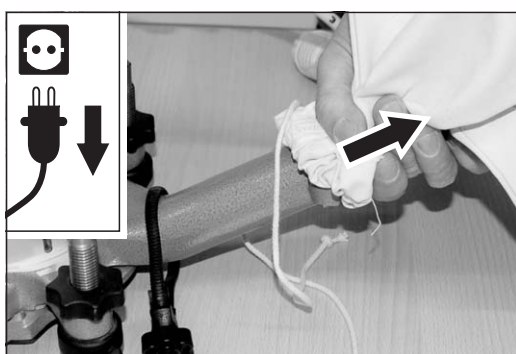

Fig. 33 Keep the opening closed and pull off the bag from the pipe muff.

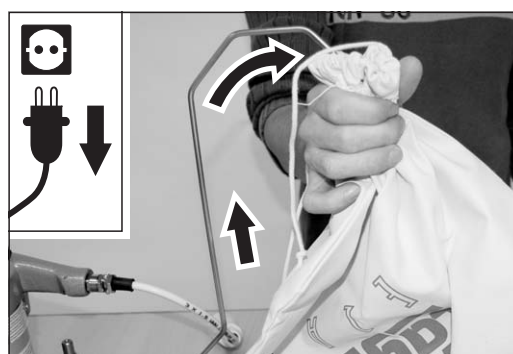

Fig. 34 Keep the opening closed and pull off the bag from the clamp.

Transport and storage

**WARNING!**

RISK OF DEATH and RISK OF PROPERTY DAMAGE from unsecured load:

When transported in a motor vehicle or the like, the machines and all parts must be secured against sliding!

RISK OF FIRE from spontaneous combustion or from the formation of sparks while sanding:

- **Oil or wax can lead to spontaneous combustion! Therefore, the machine must always be cleaned carefully directly after sanding!**
- **Always transport and store the cleaned machine without dust bag! Store used dust bags in closed and non-combustible containers!**

If the machine must be stored for a longer period of time, take the necessary measures to ensure dry and frost-free storage with minimum temperature fluctuations.

Store your unused machines in a dry, closed location out of the reach of children!

NOTE!

You can use parts of the transport packing to transport or store the machine!

Maintenance work and replacement of wearing parts



WARNING!

RISK OF DEATH from electrical shock and RISK OF INJURY from rotating parts of the machine:

- **All extensive maintenance work, especially on the electrical equipment, must be conducted by a qualified expert for safety reasons!**
- **All maintenance work and all work on the electrical equipment must be conducted with the machine switched off and with the power plug removed from the socket!**



CAUTION!

RISK OF INJURY and RISK OF PROPERTY DAMAGE:

- **Only use original spare parts from LÄGLER® (part numbers in *Section 11, Spare parts ELAM*)! This is the only way to ensure that your machine continues to perform! Warranty claims for foreign parts or damage caused thereby cannot be accepted!**
- **Never conduct the maintenance work and replacement of wearing parts on the newly sanded floor! Thus, you will avoid scratches or other damage to the floor!**
- **Do not use any cleaning products which contain solvents!**

From time to time, at the latest when damages are discovered, you must conduct various maintenance tasks and replace wearing parts. Work in a clean, well lit location and work according to these operating instructions.

An inspection of the machine can be conducted quickly and prevents the necessity of later complaints which can be caused by small damages to the machine or by worn-out parts. These measures contribute significantly to the preservation of the value of the machine and, ultimately, to your own safety.

7.1 CLEANING AND CARE

**WARNING!**

RISK OF FIRE from the formation of sparks while sanding or from spontaneous combustion:

- **There is a high risk of fire when sanding woods with a large amount of resin, oiled or waxed floors or metal! Therefore, the machine must always be cleaned carefully directly after sanding!**
- **Be certain to note the warning notices of the paint, oil and wax manufacturers!**

The following maintenance measures should be conducted before beginning work to ensure the proper functionality of the machine and the usual first-class sanding results.

- Clean the wheels of the machine.
- Check the tension of the V-belt and correct this if necessary (→ *Section 7.2, Tensioning the V-belt*).
- Clean the paper tensioning nut and the thread of the sanding disc axle. Otherwise the threads will be damaged.
- Check the dust suction system and the dust bag for leaks and damages.
- Conduct a visual inspection of the electrical equipment (switch, extension cable, plug, couplers).

Following restoration tasks, residual material consisting of adhesive, wax or sealing lacquer may have accumulated in the pulleys or in the attachment.

This can impair the running characteristics of the machine and reduce the suction performance. This kind of soiling is indicated in most cases by unsteady running, difficult starting, reduced working speed and increased development of noise. The suction performance also decreases. In this case, the V-belt must be removed (→ *Section 7.3, Replacing the V-belt*) and the attachment and flanks of the pulley must be cleaned. Check whether there are any deposits in the fan housing or on the fan blades and remove these if necessary. Wear a respiratory protective mask.

7.2 TENSIONING THE V-BELT

ATTENTION!

Do not overtighten the V-belt! This will allow you to avoid excessive wearing of the V-belt and the pulleys!

The V-belt must be re-tightened from time to time. Proceed in the following manner:

- 1 **Switch off the machine and pull the power plug out of the socket!**
- 2 Lay the machine on its side or with the motor housing on a table. Avoid damages to the floor or table and the machine.
- 3 Use the closed mouth wrench to loosen the two hexagonal nuts (wrench size 13 mm) which are used to fasten the attachment (fig. 35).
- 4 Grab the ELAN at the suction muff and press the attachment forward with your thumb at the same time (fig. 36, 1). Make sure that the distances between the threaded studs in the long holes are equal on both sides (fig. 36, distance **A** = distance **B**).
- 5 With the attachment pushed forward, use the closed mouth wrench to tighten the two hexagonal nuts (wrench size 13 mm; fig. 36, 2 + 3).

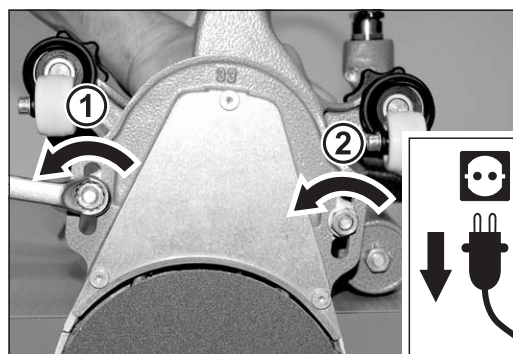

Fig. 35 Undo the two nuts with which the attachment is fastened.

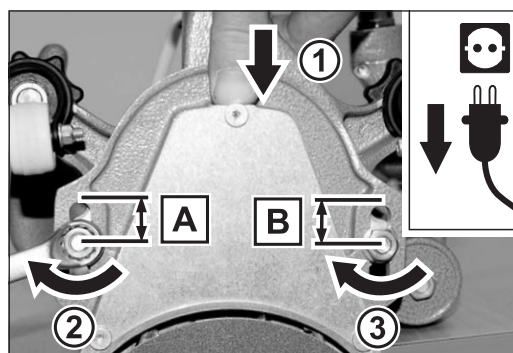

Fig. 36 Tighten the two nuts again while using your thumb to press the attachment forward in order to maintain the belt under tension. **A** and **B** should be equal.

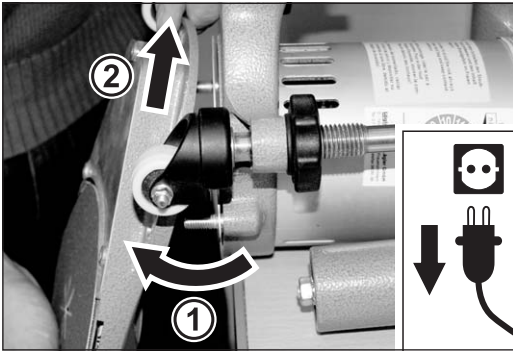

Fig. 37 Remove the two nuts and washers with which the attachment is fastened and the attachment from the machine.

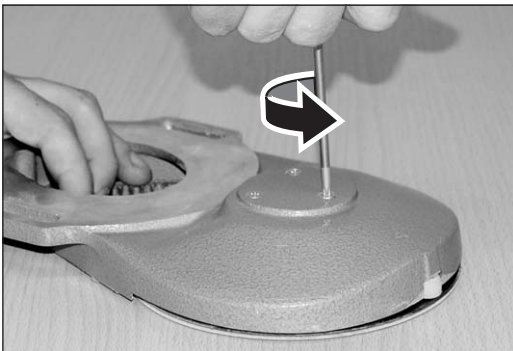

Fig. 38 With a few **light** hammer taps, the three screws are loosened and then unscrewed. Use a screwdriver with a continuous blade only.



Fig. 39 Remove the attachment from the complete sanding plate.

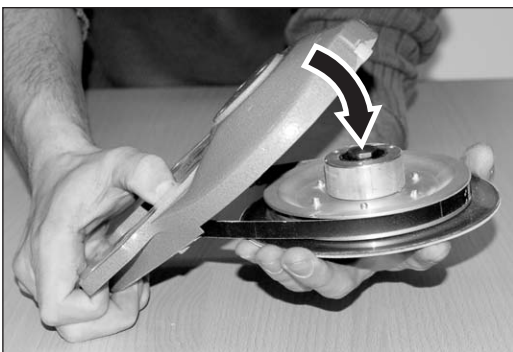

Fig. 40 Push the complete sanding plate with the V-belt into the attachment.

7.3 REPLACING THE V-BELT

Use only original LÄGLER® V-belts (part number in *Section 11, Spare parts ELAN*)!

The V-belt must be replaced when the V-belt cannot be re-tightened because the threaded studs for fastening the attachment are at the end of the long holes.

7.3.1 REMOVING THE V-BELT

- 1 **Switch off the machine and pull the power plug out of the socket!**
- 2 Lay the machine on its side or with the motor housing on a table. Avoid damages to the floor or table and the machine.
- 3 Use the closed mouth wrench to remove the two hexagonal nuts (wrench size 13 mm) and the washers which are used to fasten the attachment (fig. 35).
- 4 Remove the attachment from the machine (fig. 37) and put away the attachment with the sanding disc facing downward.
- 5 Use a screwdriver to loosen the three fastening screws of the sanding plate bearing piece and unscrew them (fig. 38).
- 6 Then remove the attachment from the complete sanding plate (fig. 39).
- 7 Remove the worn-out V-belt from the attachment.
- 8 Clean the two pulleys and the attachment. Wear a respiratory protective mask (at least filter class P2) as required.

7.3.2 INSTALLING THE V-BELT

- 1 Place the new V-belt on the sanding plate disc.
- 2 Push the complete sanding plate with the V-belt into the attachment (fig. 40). Make sure that the sanding plate can be rotated by hand and that the V-belt was correctly installed in the attachment.

- 3 Rotate the hole pattern of the sanding plate bearing piece so that it fits the hole pattern of the attachment and then insert the three screws (fig. 41).
- 4 Use a screwdriver to tighten the three screws (fig. 42).
- 5 Mount the attachment on the machine (→ *Section 5.4, Replacing the attachment, points 5 to 9*).

Check the belt tension again after running-in period of a few days and tighten the V-belt again if necessary!

7.4 REPLACING THE ATTACHMENT PULLEY

Use only original LÄGLER® attachment pulleys (part number in *Section 11, Spare parts ELAN*)!

If, when the V-belt is being changed, it is determined that the attachment pulley is worn-out, you must proceed in the following manner:

- 1 **Switch off the machine and pull the power plug out of the socket!**
- 2 Remove the attachment from the machine and then remove the attachment from the complete sanding plate (→ *7.3.1, Removing the V-belt, points 2 to 6*).
- 3 Hold down the pulley firmly with your hand and unscrew the axle **clockwise (left-hand thread)** using a wrench with wrench size 17 mm (fig. 43).
- 4 Install the new pulley and rotate until tightened down firmly.
- 5 Re-assemble the attachment again (→ *Section 7.3.2, Installing the V-belt*),

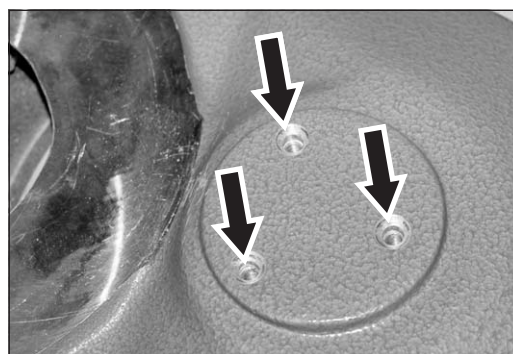

Fig. 41 Pay attention to centered insertion of the sanding plate bearing piece during assembly!

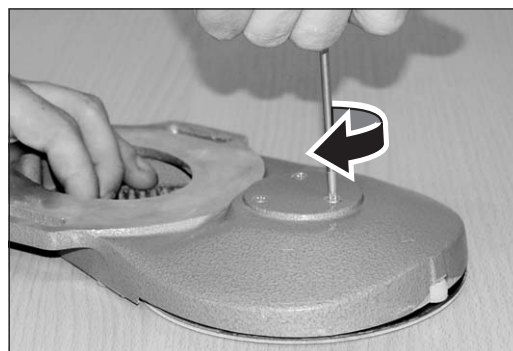

Fig. 42 Insert and tighten the three screws.



Fig. 43 Unscrew the axle **clockwise (left-hand thread)**.

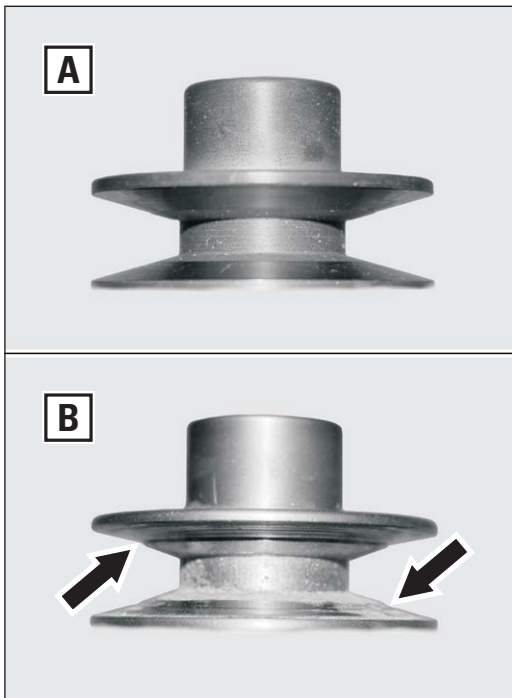

Fig. 44 **A** New motor pulley.
B Run-in motor pulley that must be replaced.

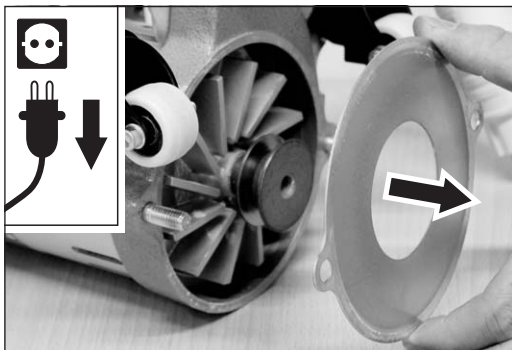

Fig. 45 Remove the fan cover.

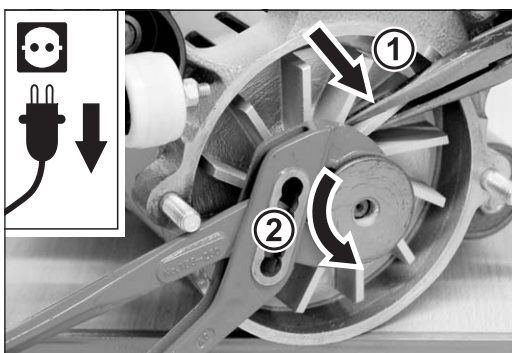

Fig. 46 Use two pairs of pliers to unscrew the motor pulley from the motor shaft.

7.5 REPLACING THE MOTOR PULLEY

Use only original LÄGLER® motor pulleys (part number in *Section 11, Spare parts ELAN*)!

Due to the high motor speed of the ELAN, the motor pulley is subjected to increased wear. The motor pulley should therefore be replaced on time in order to prevent excessive V-belt wear (fig. 44).

- 1 **Switch off the machine and pull the power plug out of the socket!**



WARNING!

RISK OF DEATH from electrical shock:

When disassembling the motor, the power plug must always be removed from the socket!

- 2 Remove the attachment from the machine (→ *Section 7.3.1, Removing the V-belt*, points 2 to 4).
- 3 Remove the fan cover (fig. 45).
- 4 Then use a pair of pliers to hold the fan wheel (fig. 46, 1) and use another pair of pliers to unscrew the motor pulley from the motor shaft **counterclockwise** (right-hand thread; fig. 46, 2).
- 5 Clean the contact surface of the motor pulley and the shaft butt end completely.
- 6 Rotate the new motor pulley onto the motor shaft **clockwise** (fig. 47).

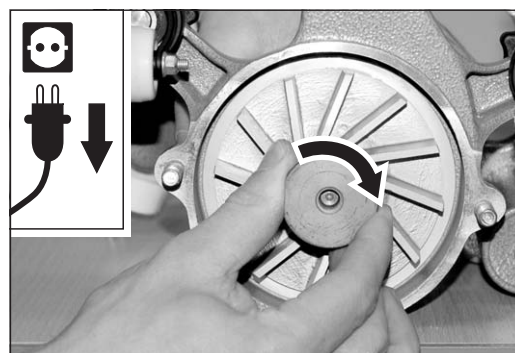

Fig. 47 Rotate the new motor pulley onto the motor shaft.

- 7 Use the two pairs of pliers to tighten down the motor pulley (fig. 48).
- 8 Place the fan cover on the machine (fig. 49).
- 9 Mount the attachment on the machine (→ *Section 5.4, Replacing the attachment, points 5 to 9*).

7.6 REPLACING THE CARBON BRUSHES

Use only original LÄGLER® carbon brushes (part number in *Section 11, Spare parts ELAN*)!

In order to prevent damage to the collector from excessively worn-out carbon brushes, LÄGLER® carbon brushes with safety contacts are used. These safety contacts automatically switch off the motor when the wear limit is reached. The carbon brushes should, however, be replaced at least once a year to avoid damage to the motor!

ATTENTION!

- **The carbon brushes must be replaced at the latest upon the reaching of the wear limit and the automatic switching off of the motor! While the automatic switching off can be prevented by pressing and holding the switch, this will cause permanent damage to the switch and the collector! These parts will then have to be replaced! There are no warranty claims for damages of this nature!**
- **Use only original ELAN carbon brushes with safety contacts (part number in *Section 11, Spare parts ELAN*)!**
- **In order to extend the service life of the motor, a qualified electrician should remove the carbon remnants on the collector every other time the carbon brushes are replaced!**



WARNING!

RISK OF DEATH from electrical shock:

- **When disassembling the motor, the power plug must always be removed from the socket!**
- **Make sure that no parts fall into the motor!**

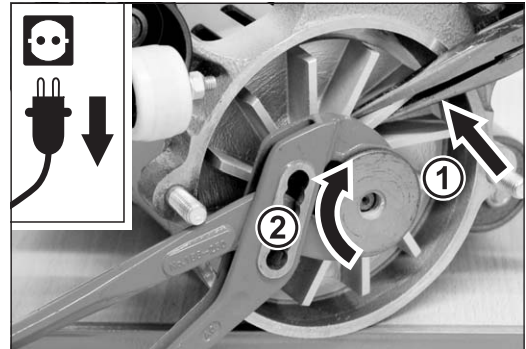

Fig. 48 Use the two pairs of pliers to tighten down the motor pulley.

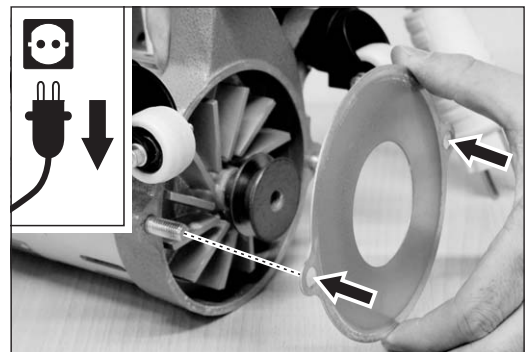

Fig. 49 Place the fan cover on the machine.



Fig. 50 Unscrew the two covers on the casing tube.

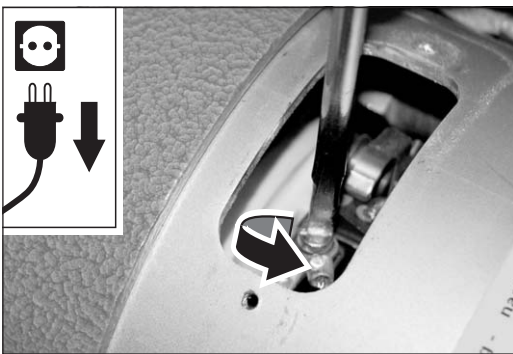

Fig. 51 Remove the fastening screw of the carbon brush.
Make sure that no parts fall into the motor!

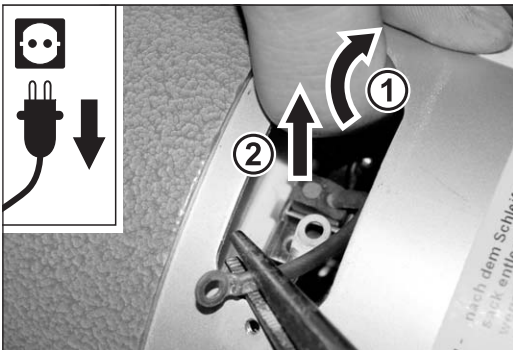

Fig. 52 Fold the tension clamp toward the right (1) and remove the carbon brush (2).

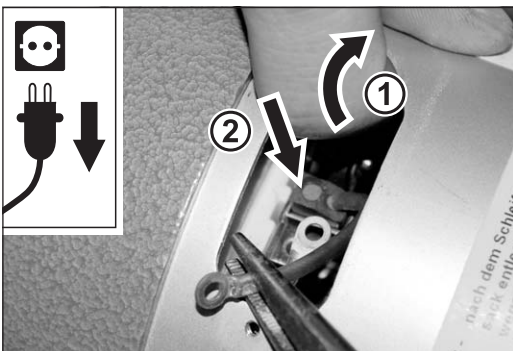

Fig. 53 With the tension clamp being held back (1), insert the new carbon brush (2).

- 1 **Switch off the machine and pull the power plug out of the socket!**
- 2 Remove and empty the dust bag (→ *Section 5.5, Emptying the dust bag, points 2 to 7*).
- 3 Remove the two cover panels at the front and rear side of the casing tube (fig. 50).
- 4 Remove the fastening screw of a carbon brush (fig. 51).
- 5 Fold down the brass pressure clamp toward the rear side, remove the worn-out carbon brush (fig. 52) and insert the new carbon brush (fig. 53).
- 6 Press down the carbon brush carefully into place.
- 7 Tighten down the cable of the carbon brush (fig. 54, **A**) and the cable of the motor winding (fig. 54, **B**).
- 8 Replace the second carbon brush as well as the first carbon brush.
- 9 Then install the two cover panels on the casing tube.



WARNING!

RISK OF DEATH from electrical shock:

Do not pinch any cables while installing the handle!

- 10 Attach the dust bag again (→ *Section 4.1, Preparing the machine*). **Wear a respiratory protective mask!**

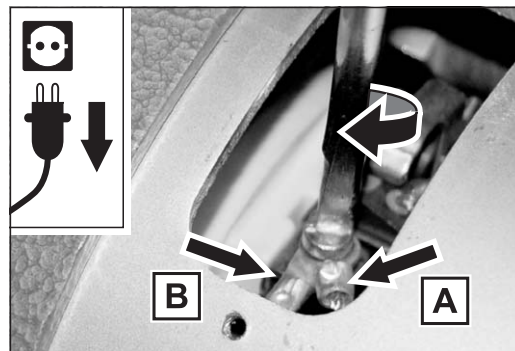

Fig. 54 Tighten down the cable of the carbon brush (**A**) and the cable of the motor winding (**B**).
Make sure that no parts fall into the motor!

7.7 CHECKING THE DUST SUCTION SYSTEM

In order to guarantee optimal dust suction for your safety and for the safety of other persons, the following items must be taken into account:

- Use only original LÄGLER® dust bags for the ELAN (part number in *Section 11, Spare parts ELAN*)!
- Do not use damaged, washed or repaired dust bags!
- Make sure that the machine is correctly adjusted (→ *Section 7.8, Adjusting the guide rollers*)!
- Make sure that the dust bag is properly fastened to the machine (→ *Section 4.1, Preparing the machine*)!
- Check the suction system for any clogged-up material or deposits!



Fig. 55 Setting of the guide rollers for short attachment and corner attachment.



Fig. 56 Setting of the guide rollers for long attachment.



Fig. 57 Flat machine setting for fine sanding tasks.



Fig. 59 Steep machine setting for rough sanding tasks.

7.8 ADJUSTING THE GUIDE ROLLERS

When using other attachments (long attachment or corner attachment; → *Section 5.4, Replacing the attachment*), the adjustment of the guide rollers must be adapted according to the changed conditions in order to achieve good sanding results (fig. 55, fig. 56).

The position of the guide rollers will affect the sanding results and the aggressiveness of the machine.

For fine sanding tasks, a flat machine setting is selected (fig. 57, fig. 58). For rough sanding tasks or if a higher amount of removed material is demanded, **no additional** pressure may be placed on the attachment; instead the machine setting must be made steeper (fig. 59, fig. 60).

The high cutting speed of the machine allows you to work fast. The machine must be moved quickly without applying extra pressure.

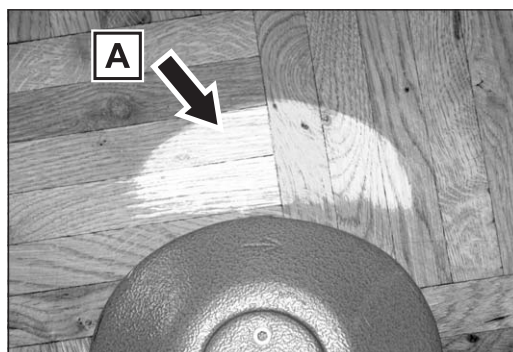

Fig. 58 Large sanding area **A** and therefore low aggressiveness of the sanding disc.

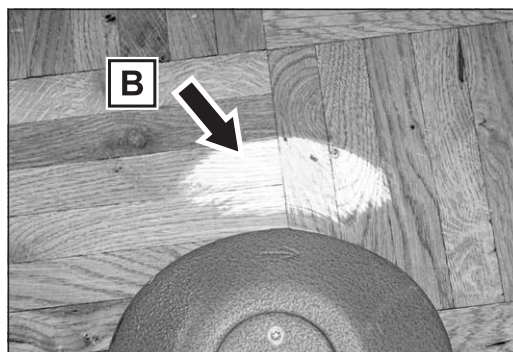

Fig. 60 Small sanding area **B** and therefore high aggressiveness of the sanding disc.

 MAINTENANCE WORK AND REPLACEMENT OF WEARING PARTS

To adjust the guide rollers, proceed in the following manner:

- 1 **Switch off the machine and pull the power plug out of the socket!**
- 2 Loosen the lock nuts of the guide rollers (fig. 61).
If a lock nut is screwed on too tightly, you can turn the guide roller axis counterclockwise with a screwdriver (Torx T15) to loosen the lock nut.
- 3 Then rotate the guide rollers into the desired direction.
To get a **flatter** machine setting for **fine** sanding tasks rotate the guide roller axis **counterclockwise** (fig. 62, 1 + 2). Thereby the fan housing is **lowered** (fig. 62, 3).
To get a **steeper** machine setting for **rough** sanding tasks rotate the guide roller axis **clockwise** (fig. 63, 1 + 2). Thereby the fan housing is **lifted** (fig. 63, 3).
- 4 Tighten down the lock nuts again.
- 5 Perform a trial sanding operation and check the sanding results.
- 6 If the machine sands **centrically** (fig. 64), the guide rollers are properly adjusted.

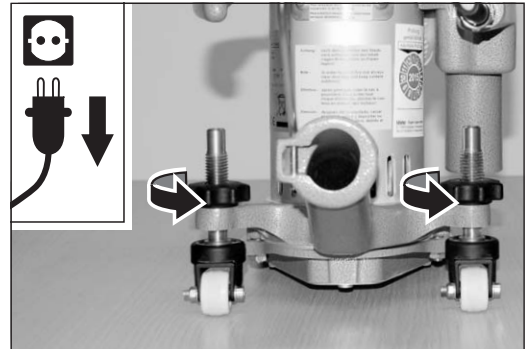

Fig. 61 Loosen the lock nuts of the guide rollers.

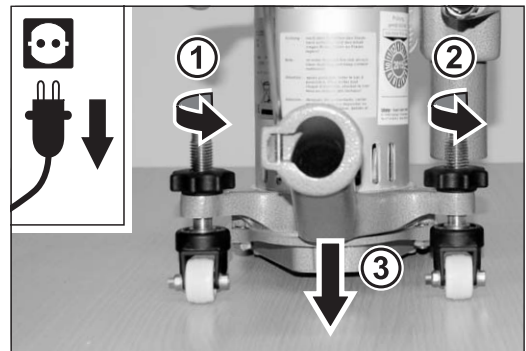

Fig. 62 For a **flatter** machine setting rotate the guide roller axis **counterclockwise** (1 + 2). Thereby the fan housing is **lowered** (3).

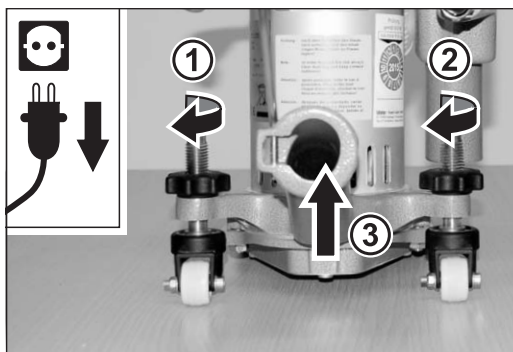

Fig. 63 For a **steeper** machine setting rotate the guide roller axis **clockwise** (1 + 2). Thereby the fan housing is **lifted** (3).

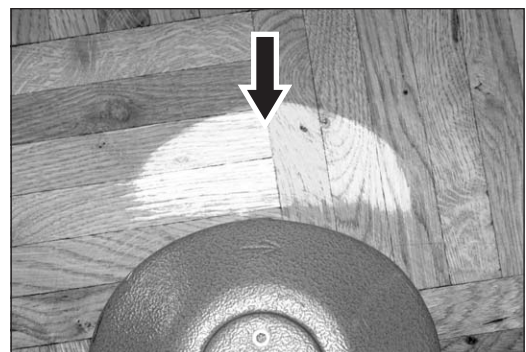

Fig. 64 **Proper** adjustment of the guide rollers:
The machine sands **centrically**.



Fig. 65 **Improper** adjustment of the guide rollers:
The sanding zone of the machine is too much to the **right**.



Fig. 66 The sanding zone of the machine is too much to the **right** means, the **left** guide roller (**A**) is lifting the machine more than the right guide roller (**B**).

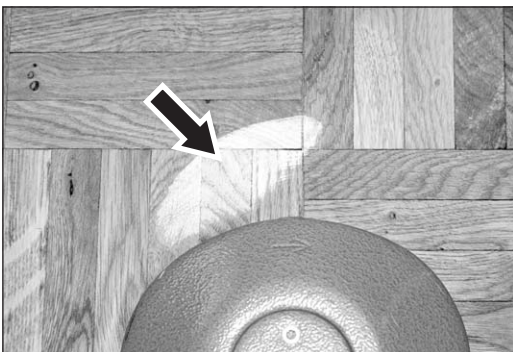

Fig. 67 **Improper** adjustment of the guide rollers:
The sanding zone of the machine is too much to the **left**.



Fig. 68 The sanding zone of the machine is too much to the **left** means, the **right** guide roller (**A**) is lifting the machine more than the left guide roller (**B**).

7 If the machine sands too much to the right (fig. 65) or to the left (fig. 67), the guide rollers are **not adjusted to the same height** (fig. 66, fig. 68)!

8 Adjust both guide rollers to the **same height** (points 1 to 4) and repeat the trial sanding operation.

7.9 REPLACING THE WHEELS AND THE GUIDE ROLLERS

ATTENTION!

- **Blocked wheels or guide rollers restrict the mobility of the machine and leave marks on the floor! These parts must be replaced!**
- **Always replace both wheels or guide rollers!**

7.9.1 REPLACING THE WHEELS

Use only original LÄGLER® wheels (part number in *Section 11, Spare parts ELAN*)!

The wheels must be replaced when the contact surfaces are worn-out or damaged or the wheels can only be turned by applying additional force.

- 1 Switch off the machine and pull the power plug out of the socket!**
- Remove the screw with the two washers and the nut from the wheel fork (fig. 69, 1).
- Remove the wheel from the wheel fork (fig. 69, 2).
- Install the new wheel in the reverse order.

7.9.2 REPLACING THE GUIDE ROLLERS

Use only original LÄGLER® guide rollers (part number in *Section 11, Spare parts ELAN*)!

The guide rollers must be replaced when the wheel forks only rotate around the vertical guide roller axes with increased force!

- 1 Switch off the machine and pull the power plug out of the socket!**
- Remove the lock nut of the guide roller (fig. 61).

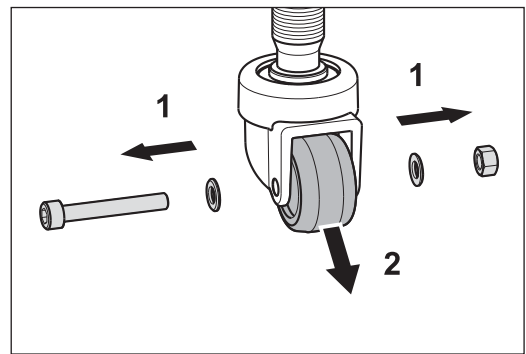

Fig. 69 Remove the screw, the two washers and the nut (1) and remove the wheel from the wheel fork (2).

- 3 Rotate the vertical guide roller axis completely out of the fan housing.

NOTE:

A light film of oil on the thread of the new guide roller makes the adjustment work easier.

- 4 Rotate the vertical axis of the new guide roller into the fan housing.
- 5 Mount the lock nut and tighten it.
- 6 Check the setting of the guide rollers (→ *Section 7.8, Adjusting the guide rollers*).

7.10 REPLACING THE WALL-PROTECTING ROLLER

Use only original LÄGLER® wall-protecting rollers (part number in *Section 11, Spare parts ELAN*)!

- 1 **Switch off the machine and pull the power plug out of the socket!**
- 2 Remove the attachment from the machine and then remove the attachment from the complete sanding plate (→ *Section 7.3.1, Removing the V-belt, points 2 to 6*).
- 3 Unscrew and remove the wall-protecting roller from the attachment.
- 4 Mount a new wall-protecting roller.
- 5 Mount the complete sanding plate with V-belt into the attachment and then mount the attachment on the machine (→ *Section 7.3.2, Installing the V-belt*).

Regular inspection and maintenance work in accordance with accident prevention regulations

The electrical operating equipment and machine parts must be inspected at least once a year by a qualified electrician with respect to electrical and mechanical safety, then be repaired as required. Afterwards, the operational safety must be confirmed by the attachment of an inspection label on the machine (fig. 70).

The elements required for the dust suction system must be checked at least once a year by a qualified expert and repaired as required. The functional efficiency must also be confirmed.

Ensure that only original LÄGLER® spare parts are used for maintenance work! You should only allow the customer service work to be conducted by LÄGLER® or an authorized LÄGLER® service center!

The service passport in these operating instructions (*Section 12*) documents when and where your machine was serviced.

Enter the serial number and the year of manufacture of your machine (please see the type plate) on the back cover of these operating instructions! If you do not do this, your service passport is invalid!

Make sure that the maintenance tasks in the service passport are confirmed by filling in a corresponding field with the date, stamp and signature.

REGULATIONS VALID IN GERMANY

The German Ordinance on Industrial Safety and Health (BetrSichV) requires every employer to define the testing intervals on the work equipment they provide according to a risk analysis and to document all of this.



WARNING!

Tests and testing intervals must comply with and be performed in accordance with the applicable regulations and legal requirements in your country!



Fig. 70 The inspection label on the motor housing confirms the electrical and mechanical safety of the machine.



WARNING!

In order to ensure the safety of the machines and equipment (= working equipment), the German Ordinance on Industrial Safety and Health (BetrSichV) must be complied with in Germany!

NOTE:

- All LÄGLER® machines and electrical equipment are subjected to an electrical inspection as well as a thorough visual and functional test before they leave the factory.
- A recurring inspection of the machines and electrical equipment must be conducted in Germany at certain intervals.
- LÄGLER® recommends using the guidelines of the German accident prevention regulations “**DGUV Vorschrift 3**” for inspections and inspection intervals.
- You can, of course, arrange for repairs and recurring inspections of LÄGLER® machines to be conducted by the LÄGLER® service department.

EXCERPT FROM THE GERMAN ACCIDENT PREVENTION REGULATIONS “DGUV VORSCHRIFT 3” (November 2013)

§ 5 Inspections

- (1) The employer must ensure that the proper condition of the electrical systems and equipment is inspected
 1. before using the equipment for the first time and after an alteration or repair before being used again by an electrician or under the supervision of an electrician and
 2. at regular intervals.

The intervals are to be calculated in such a manner that defects which must be handled are detected in a timely manner.

- (2) The electrical engineering regulations relevant to the inspection are to be followed.
- (3) Upon request by the professional association, an inspection log with specific entries is to be maintained.
- (4) The inspection before the first commissioning as per paragraph 1 is not required if the employer receives confirmation from the manufacturer or installer that the electrical systems and equipment have been correspondingly procured in accordance with these accident prevention guidelines.

Table 1B: Recurring inspections of portable electrical equipment:

Systems/equipment (which are to be inspected)

- portable electrical equipment (insofar as is used)
- extension and device connection cables with plugs
- connection cables with plugs
- movable cables with plugs and fixed connections

Inspection interval

Every 6 months as a reference value, **3 months on construction sites***).

If an error rate of less than 2% is reached during the inspection, the inspection interval can be extended to a maximum of 1 year (valid for machines on construction sites, in production facilities and workshops).

*) See the BG information “Selection and Operation of Electrical Systems and Equipment on Construction Sites” (DGUV Information 203-006) for more details.

Type of inspection

The proper condition of the machines and equipment must be inspected.

Inspector

Electricians or persons trained in electrical engineering when using suitable measurement and inspection devices.

Causes of faults

This section shows you how to remedy possible malfunctions. If none of the measures listed here are successful, please contact our service department, your retailer or your importer.

9.1 THE MACHINE DOES NOT RUN OR HAS SWITCHED OFF AUTOMATICALLY

- The machine is not connected to the electrical network. Check the following items:
 - Is the motor cable connected to the extension cable?
 - Is the extension cable inserted into the power socket?
- The power socket is not properly connected. This error must be corrected by an expert.
- The electrical safety device of the electrical network interrupted the electrical circuit, e.g. because
 - too many electricity consumers are connected to the same electrical circuit,
 - improper electrical installation.
 The causes for the error must be repaired by an expert.
- The electrical network is not providing sufficient voltage (undervoltage). Use a transformer if necessary (e.g. LÄGLER® part number 708.00.00.100 for 230 volts).
- The temperature switch in the motor has switched off the machine because
 - the power cables have a total length of more than 20 m (790"),
 - the power cables have wire cross-sections smaller than 1.5 mm² (0.0023 sq. in.),
 - or too much pressure was applied to the attachment while sanding.
 The motor must cool off and the causes for the problems named above must be remedied.
- An electrical component of the machine (e.g. cable, switch) is defective and must be inspected by a qualified electrician and replaced if necessary.
- The wear limit of the carbon brushes has been reached. The carbon brushes must be replaced.

Use only original LÄGLER® ELAN carbon brushes with safety contacts (part number in Section 11, Spare parts ELAN)!

➔ Section 7.6, Replacing the carbon brushes



WARNING!

RISK OF DEATH from electrical shock:

Work on the electrical equipment is to be conducted exclusively by a qualified electrician (circuit diagrams in *Section 10*)! The machine must be switched off and the power plug removed from the socket during this work!

RISK OF INJURY due to unsuitable parts:

Make sure that only original LÄGLER® spare parts and original LÄGLER® accessories are used!

9.2 THE MACHINE ATTEMPTS TO START UP BUT IS NOT ABLE TO DO SO

- At low temperatures: The machine is too cold and must be heated up to room temperature in a warm room.
- Cables which are too long or too thin are used for the electrical connection:
 - The power cables have a total length of more than 20 m (790").
 - The power cables have wire cross-sections smaller than 1.5 mm² (0.0023 sq. in.).
 This causes of faults lead to a loss of power and are not allowed for safety reasons!
- The electrical network is not providing sufficient voltage (undervoltage). Use a transformer if necessary (e.g. LÄGLER® part number 708.00.00.100 for 230 volts).
- The V-belt is too tight and must be loosened.
 ➔ *Section 7.2, Tensioning the V-belt*

9.3 THE MACHINE RUNS BUT HAS NO OR VERY LITTLE SANDING POWER CAPACITY

- The sanding medium is incorrect or dull and must be replaced.
 ➔ *Section 5.2, Replacing the sanding disc*
- At low temperatures: The machine is too cold and must be heated up to room temperature in a warm room.
- Cables which are too long or too thin are used for the electrical connection:
 - The power cables have a total length of more than 20 m (790").
 - The power cables have wire cross-sections smaller than 1.5 mm² (0.0023 sq. in.).
 This causes of faults lead to a loss of power and are not allowed for safety reasons!
- The electrical network is not providing sufficient voltage (undervoltage). Use a transformer if necessary (e.g. LÄGLER® part number 708.00.00.100 for 230 volts).
- The V-belt is not tight enough and must be tensioned a bit.
 ➔ *Section 7.2, Tensioning the V-belt*
- The machine setting angle is too flat. The guide rollers must be properly adjusted.
 ➔ *Section 7.8, Adjusting the guide rollers*

9.4 THE MACHINE VIBRATES INTENSELY AND RUNS NOISILY

- The sanding medium does not have the proper tension. The tension must be corrected.
➔ *Section 5.2, Replacing the sanding disc*
- The sanding medium is damaged or incorrect and must be replaced.
➔ *Section 5.2, Replacing the sanding disc*
- The V-belt is dirty, damaged or worn-out and must be replaced.
➔ *Section 7.3, Replacing the V-belt*
- A pulley is dirty, damaged or worn-out and must be cleaned or replaced.
➔ *Section 7.4, Replacing the attachment pulley*
➔ *Section 7.5, Replacing the motor pulley*
- There are clogged materials and deposits in the machine that must be removed.
➔ *Section 7.1, Cleaning and care*

9.5 THE MACHINE RUNS BUT CREATES A GREAT DEAL OF DUST

- The dust bag is more than one third full and must be emptied.
➔ *Section 5.5, Emptying the dust bag*
- The dust bag is not correctly attached or is damaged and must be replaced.
➔ *Section 4.1, Preparing the machine*
- There are clogged materials and deposits in the machine that must be removed.
➔ *Section 7.1, Cleaning and care*
- More than one sanding disc is mounted. Only install one sanding disc.
➔ *Section 5.2, Replacing the sanding disc*
- The machine setting is too steep. The guide rollers must be properly adjusted.
➔ *Section 7.8, Adjusting the guide rollers*

- The movement of the machine while sanding is incorrect:
 - Move the ELAN with **short or long attachment** in **circular** motions **clockwise!**
 - Move the ELAN with **corner attachment** in **circular** motions **counterclockwise!**
 ➔ *Section 5.1, General application tips*
- Too much pressure is placed on the sanding disc while sanding. Do not press too hard on the attachment while sanding.

9.6 SANDING PROBLEMS (WAVES, STRIPS, GROOVES)

- The floor or stairs were not vacuumed before sanding. The floor or stairs must always be vacuumed thoroughly before the first and after each additional sanding operation.
- The sanding disc was not lifted from the floor while the machine was switched on or off. Always tilt the machine backwards slightly before switching on or off so that the sanding disc is lifted off the floor.
 - ➔ *Section 4.3, Switching on the machine*
 - ➔ *Section 4.4, Switching off the machine*
- The machine is being moved too slowly and must be sped up.
- The movement of the machine while sanding is incorrect:
 - Move the ELAN with **short or long attachment** in **circular** motions **clockwise!**
 - Move the ELAN with **corner attachment** in **circular** motions **counterclockwise!**
 ➔ *Section 5.1, General application tips*
- The sanding medium does not have the proper tension. The tension must be corrected.
 - ➔ *Section 5.2, Replacing the sanding disc*
- The sanding medium is damaged or incorrect and must be replaced.
 - ➔ *Section 5.2, Replacing the sanding disc*
- The machine setting is incorrect. The guide rollers must be properly adjusted.
 - ➔ *Section 7.8, Adjusting the guide rollers*
- The wheels are dirty or damaged and must be cleaned or replaced.
 - ➔ *Section 7.9, Replacing the wheels and the guide rollers*

CAUSES OF FAULTS

- The V-belt is dirty, damaged or worn-out and must be replaced.
➔ *Section 7.3, Replacing the V-belt*
- A pulley is dirty, damaged or worn-out and must be cleaned or replaced.
➔ *Section 7.4, Replacing the attachment pulley*
➔ *Section 7.5, Replacing the motor pulley*
- Too much pressure is placed on the sanding disc while sanding. Do not press too hard on the attachment while sanding.

CIRCUIT DIAGRAMS

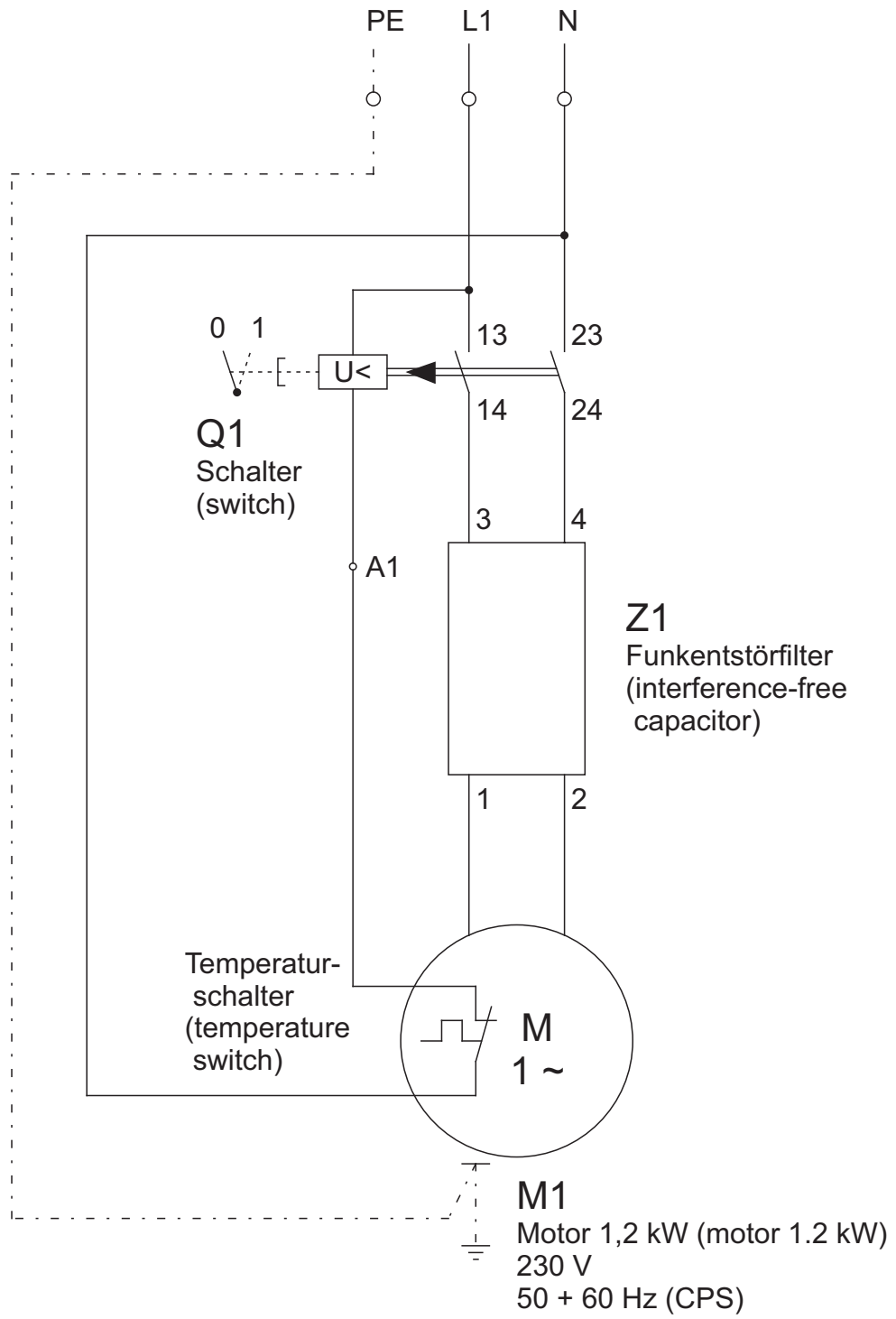

01.04.2008

<p>ELAN: Universalmotor (universal motor)</p>	<p>1,2 kW (1.2 kW) / 230 V / 50 + 60 Hz (CPS)</p>	
<p>EUGEN LÄGLER GMBH Kappelrain 2 D-74363 Güglingen-Frauenzimmern</p>	<p>Telefon Phone: 0049 - 7135 - 98 90 - 0 Fax: 0049 - 7135 - 98 90 - 98</p>	<p>e-mail: info@laegler.com Internet: http://www.laegler.com</p>

CIRCUIT DIAGRAMS

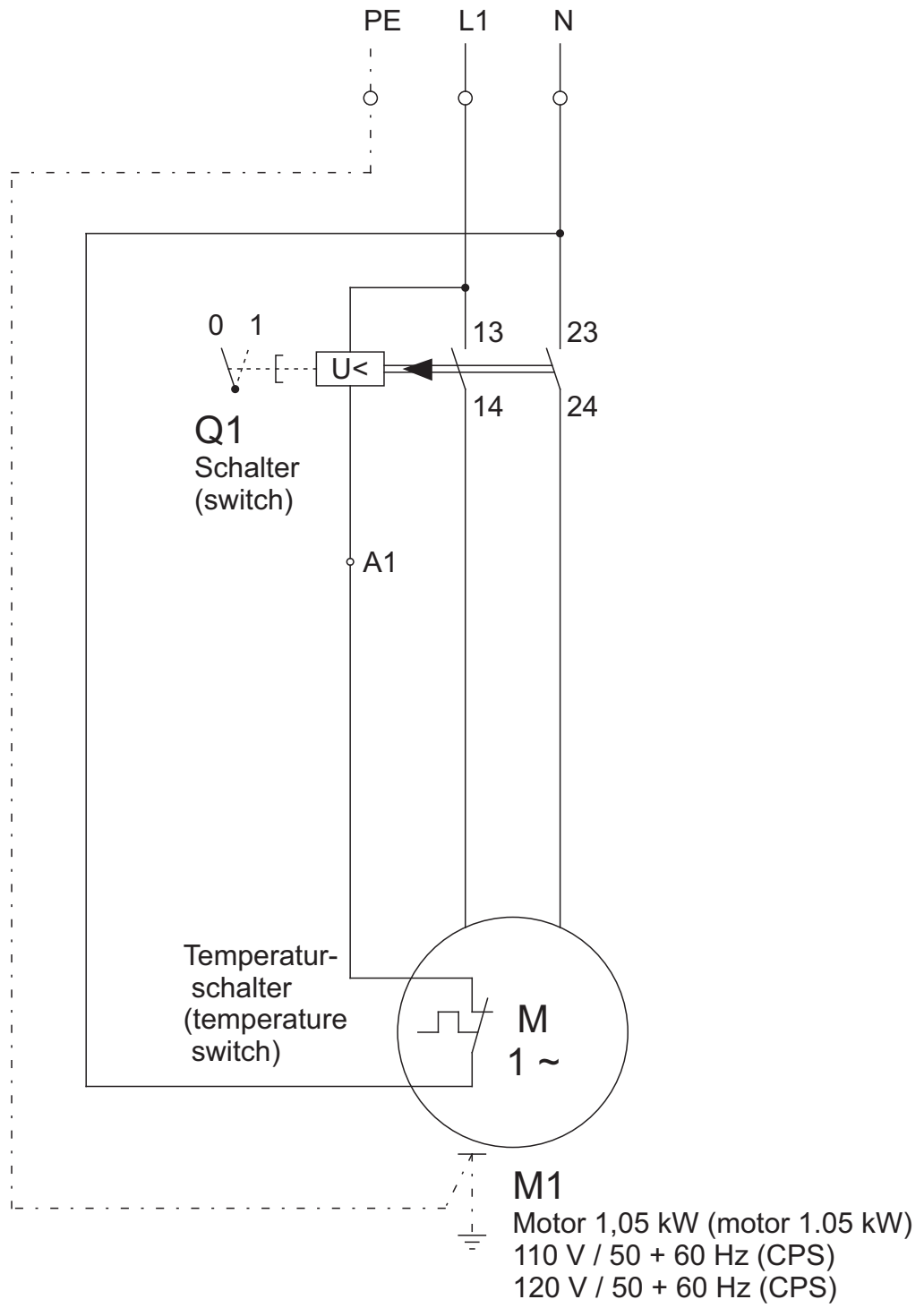

01.01.2014

<p>ELAN: Universalmotor (universal motor)</p>	<p>1,05 kW (1.05 kW) / 110 V / 50 + 60 Hz (CPS) 1,05 kW (1.05 kW) / 120 V / 50 + 60 Hz (CPS)</p>	
<p>EUGEN LÄGLER GMBH Kappelrain 2 D-74363 Güglingen-Frauenzimmern</p>	<p>Telefon Phone: 0049 - 7135 - 98 90 - 0 Fax: 0049 - 7135 - 98 90 - 98</p>	<p>e-mail: info@laegler.com Internet: http://www.laegler.com</p>

SPARE PARTS ELAN

ATTENTION: Please specify in inquiries and spare part orders always the serial numbers (→ Section 3.1)!

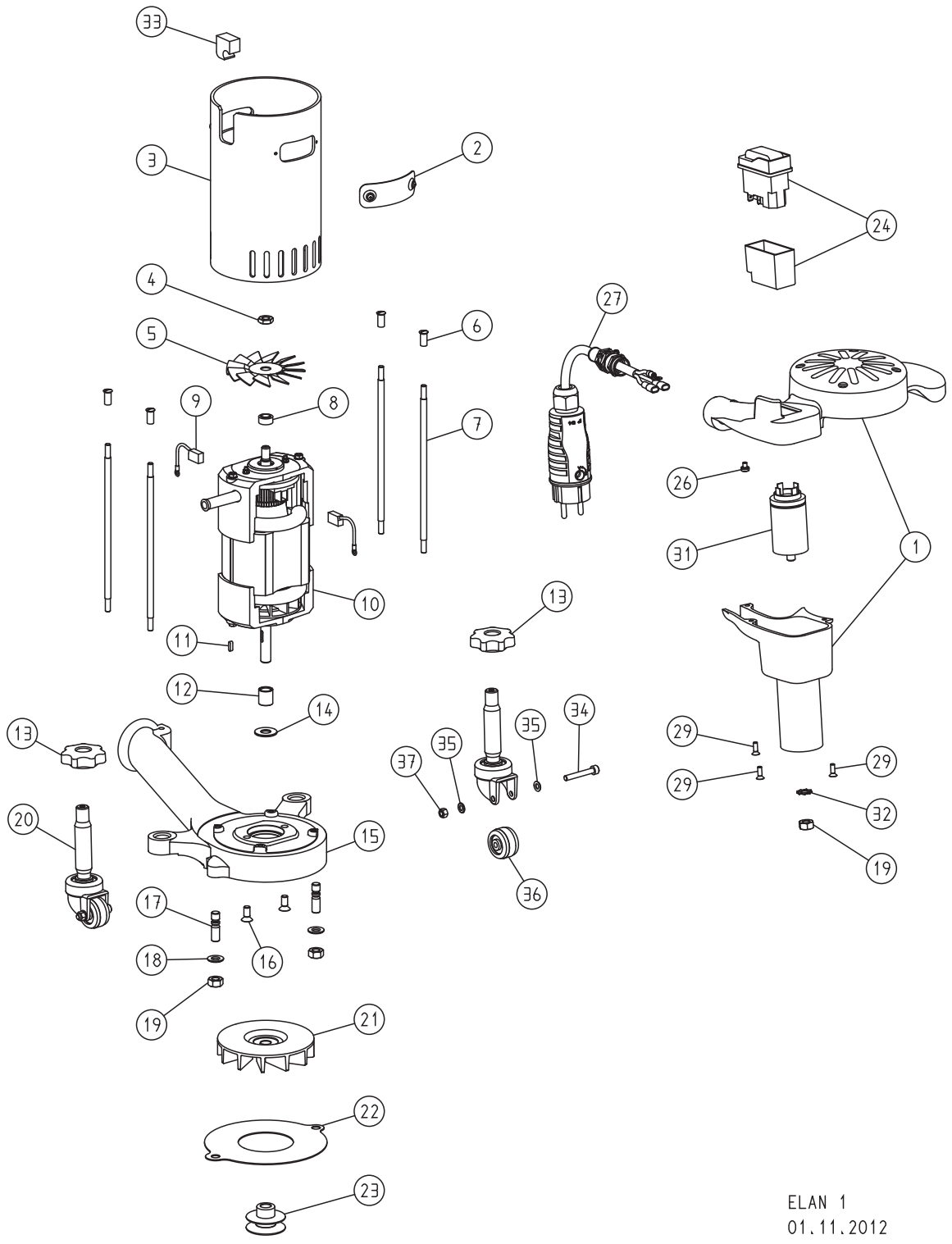

ELAN 1
01.11.2012

SPARE PARTS ELAN

Item	Part number	Description
1	350.05.00.100	Handle ELAN, complete
	352.05.00.100	Handle ELAN USA, complete
2	350.05.15.100	Cover, complete
3	350.05.10.100	Casing tube, complete
4	0439.1008.800	Nut, left-handed thread
5	350.65.02.100	Fan blade
6	000.50.14.051	Sleeve nut
7	350.01.03.105	Spacer bolt
8	350.65.04.105	Spacer ring
9	350.65.82.105	Carbon brush ELAN
10	350.65.00.200	Universal motor, 230 V / 50 + 60 CPS
	352.65.00.200	Universal motor, 110 V / 50 + 60 CPS
11	6885.0303.010	Parallel key
12	350.65.06.105	Spacer bush
13	320.05.11.205	Star grip (locknut)
14	000.10.10.104	Washer
15	350.01.01.100	Fan housing
16	0965.1006.814	Screw
17	0939.1008.020	Stud
18	0125.1008.000	Washer
19	0934.1008.000	Nut
20	320.05.00.200	Guide roller, complete
21	350.65.03.100	Fan wheel
22	350.01.02.100	Fan cover
23	350.65.05.100	Motor pulley
24	000.65.60.255	Switch 230 V / 50 + 60 CPS with dust cover
	000.65.60.155	Switch 110 V / 50 + 60 CPS with dust cover
	000.65.62.160	PVC cap with switch frame
26	7985.4004.006	Screw
27	000.65.43.151	Motor cable 3 x 1.5 mm ²
	000.65.43.153	Motor cable 3 x 1.5 mm ² , USA
29	7500.1004.812	Screw
31	000.65.18.010	Interference-free capacitor
32	6797.1008.900	Washer
33	350.05.31.100	Sealing rubber
34	0912.1005.035	Screw
35	0125.1005.000	Washer
36	320.05.09.305	Wheel
37	0980.1005.000	Nut

ATTENTION: Please specify in inquiries and spare part orders always the serial numbers of your machines (→ Section 3.1)!

SPARE PARTS ELAN

ATTENTION: Please specify in inquiries and spare part orders always the serial numbers of your machines (→ Section 3.1)!

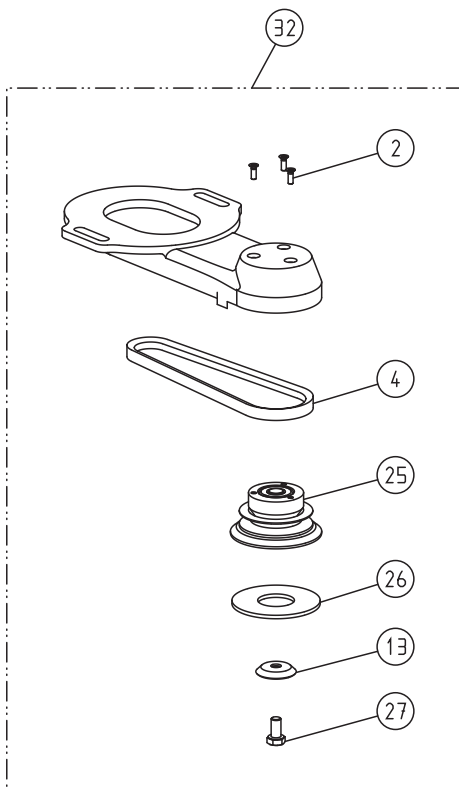
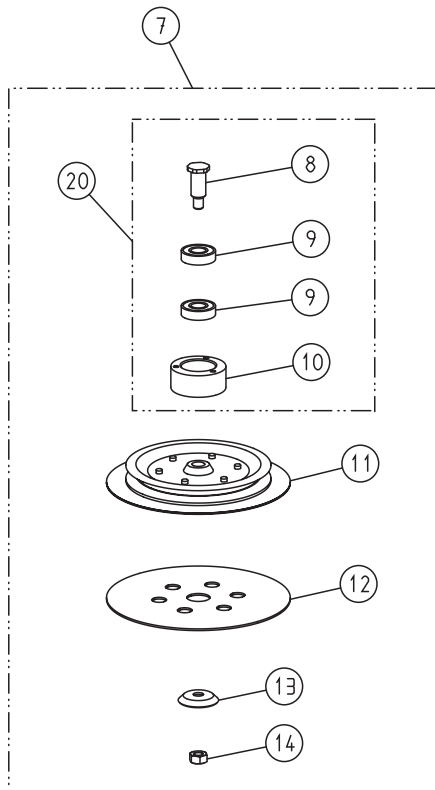
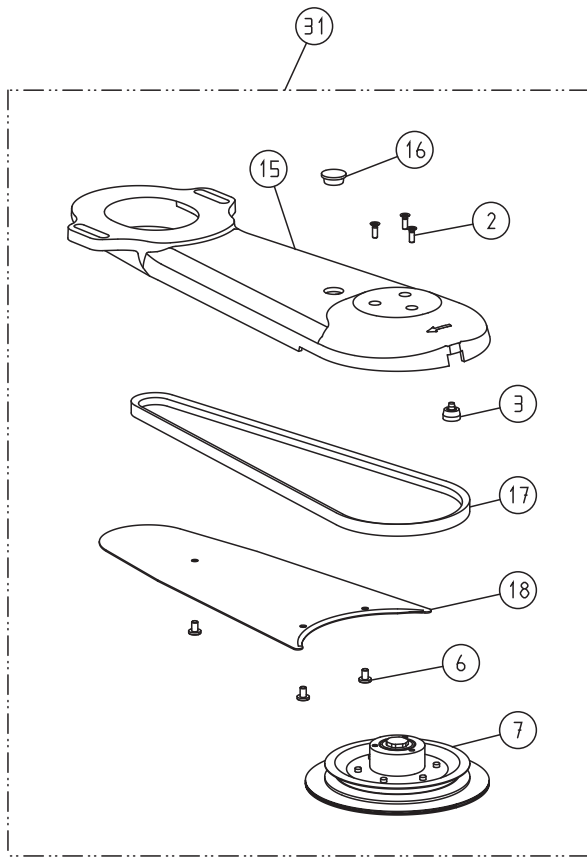
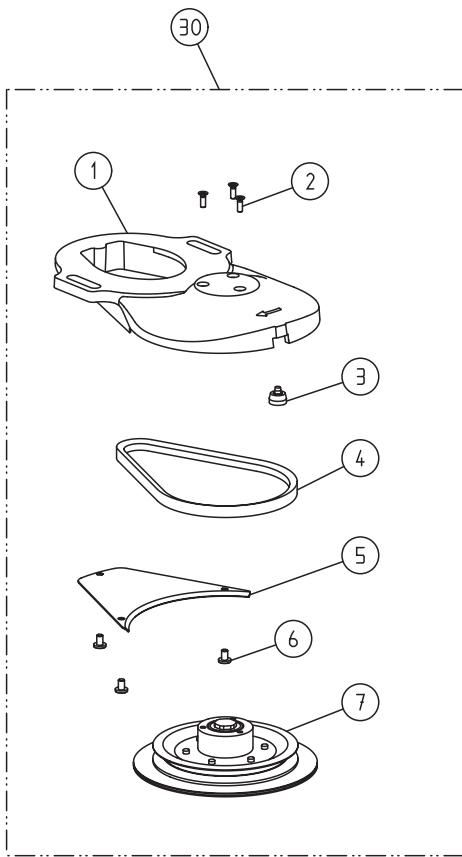

ELAN 2
01.01.2019

SPARE PARTS ELAN

Item	Part number	Description
1	350.03.01.100	Short attachment ELAN (only housing)
2	7500.1004.812	Screw
3	350.03.25.100	Wall-protecting roller, complete
4	000.70.10.045	V-belt
5	350.03.02.100	Cover, short
6	000.10.12.051	Screw
7	350.03.52.100	Sanding plate, complete
8	350.03.12.105	Sanding disc axle
9	6001.0012.202	Ball bearing
10	350.03.11.100	Bearing ring
11	350.03.56.100	Attachment pulley, complete
12	350.03.35.205	Velcro disc 150 mm
	350.03.34.105	Felt disc 150 mm
13	350.03.16.100	Paper tensioning disc
14	0934.1008.000	Nut
15	350.04.01.100	Long attachment ELAN (only housing with plug)
16	000.40.30.017	Plug
17	000.70.10.085	V-belt
18	350.04.02.100	Cover, long
20	350.03.48.100	Bearing ring, complete
25	350.08.10.100	Sanding plate 75 mm, complete
26	350.08.13.105	Felt disc 75 mm
27	0933.1008.016	Screw
30	350.03.50.100	Short attachment ELAN, complete
31	350.04.50.100	Long attachment ELAN, complete
32	350.08.00.100	Corner attachment ELAN, complete

ATTENTION: Please specify in inquiries and spare part orders always the serial numbers of your machines (→ Section 3.1)!

SPARE PARTS ELAN

ATTENTION: Please specify in inquiries and spare part orders always the serial numbers of your machines (→ Section 3.1)!

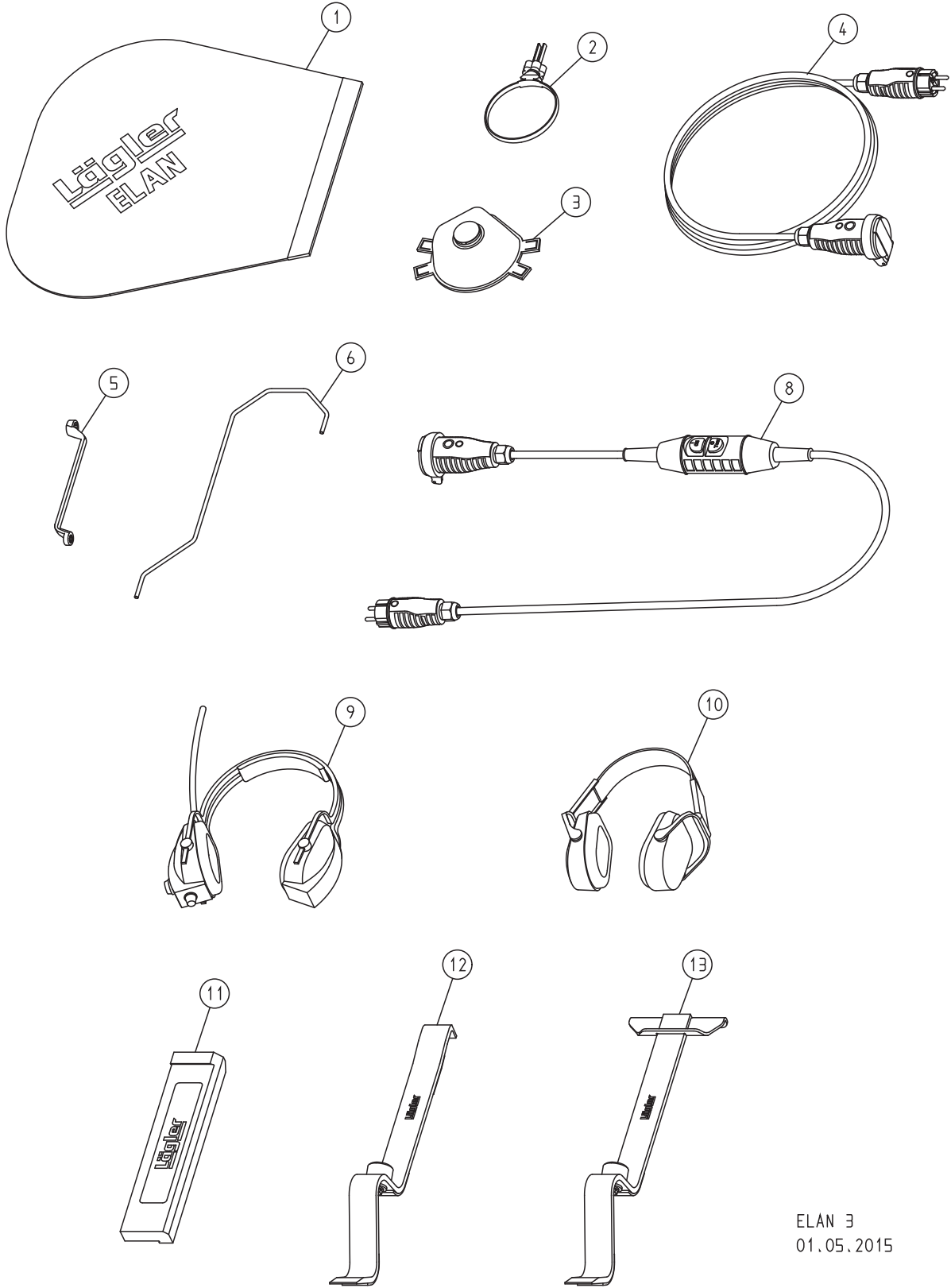

ELAN 3
01.05.2015

SPARE PARTS ELAN

Item	Part number	Description
1	350.00.80.105	Dust bag ELAN
2	000.01.40.110	MultiClip
3	000.01.20.010	Respiratory protection mask P3
4	000.65.53.151	Extension cable 3 x 1.5 mm ² , 10 m long
5	000.95.21.103	Closed mouth wrench 10/13 mm
6	350.01.05.200	Dust bag clamp
8	000.01.65.020	Safety switch PRCD-S (for German mains supply)
9	000.01.10.011	Foldable earmuff type MUSIMUFF with FM radio
10	000.01.10.021	Foldable earmuff type POCKET
11	701.10.00.100	Impact tool
12	702.00.00.200	Parquet layer tool ZUGEISEN, small
13	703.00.00.200	Parquet layer tool ZUGEISEN, broad

ATTENTION: Please specify in inquiries and spare part orders always the serial numbers of your machines (→ Section 3.1)!

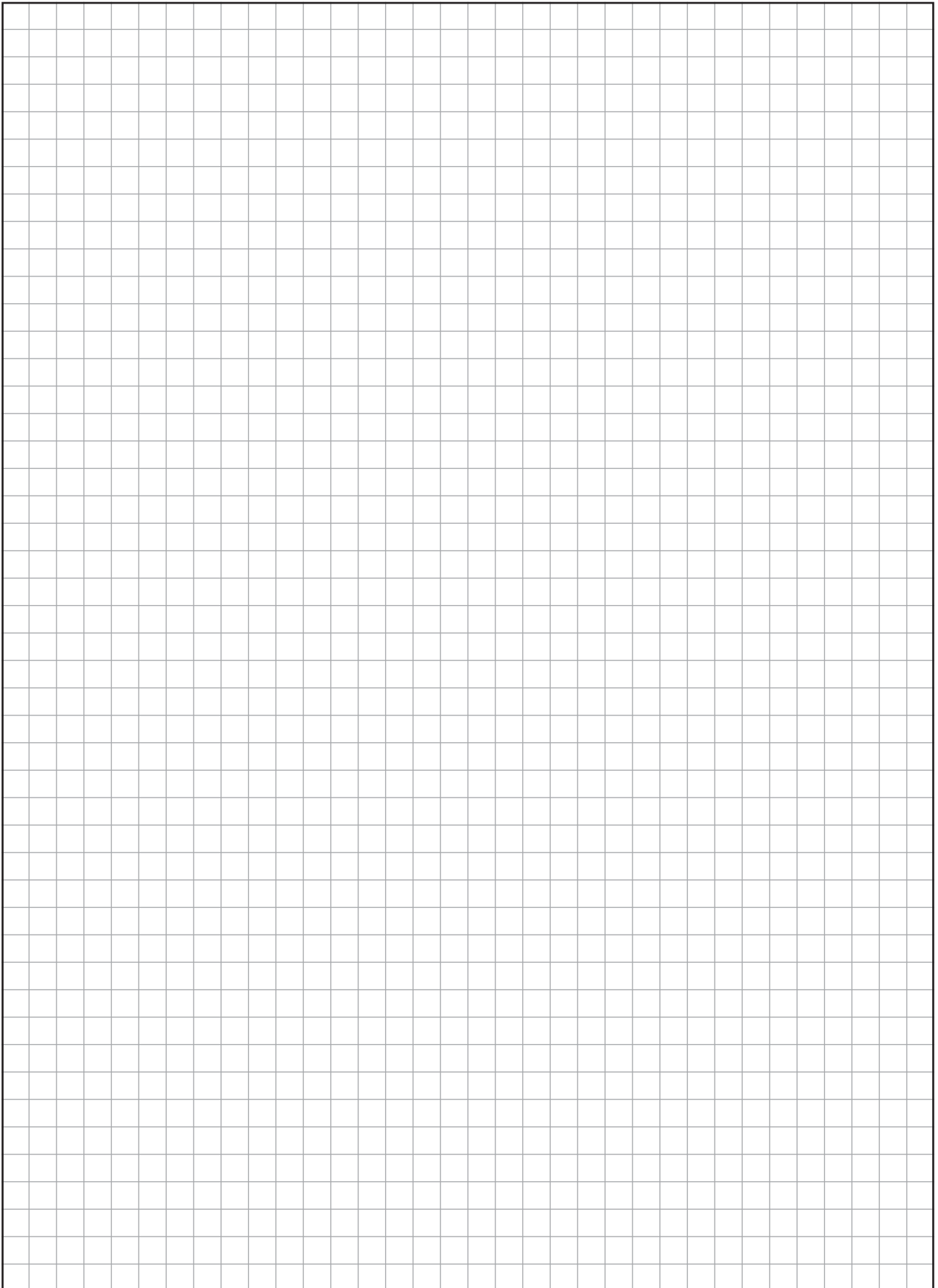

Service passport

Please enter the serial number and the year of manufacture of your machine (see type plate) on the rear side of these operating instructions! Otherwise the service passport will not be valid!

This service passport is a document. Make sure that all the tests and maintenance work carried out on the machine are confirmed by the servicing company here.

<p>Date of test and maintenance work: _____</p> <p>Signature and company stamp</p>	<p>Date of test and maintenance work: _____</p> <p>Signature and company stamp</p>	<p>Date of test and maintenance work: _____</p> <p>Signature and company stamp</p>
<p>Date of test and maintenance work: _____</p> <p>Signature and company stamp</p>	<p>Date of test and maintenance work: _____</p> <p>Signature and company stamp</p>	<p>Date of test and maintenance work: _____</p> <p>Signature and company stamp</p>
<p>Date of test and maintenance work: _____</p> <p>Signature and company stamp</p>	<p>Date of test and maintenance work: _____</p> <p>Signature and company stamp</p>	<p>Date of test and maintenance work: _____</p> <p>Signature and company stamp</p>
<p>Date of test and maintenance work: _____</p> <p>Signature and company stamp</p>	<p>Date of test and maintenance work: _____</p> <p>Signature and company stamp</p>	<p>Date of test and maintenance work: _____</p> <p>Signature and company stamp</p>
<p>Date of test and maintenance work: _____</p> <p>Signature and company stamp</p>	<p>Date of test and maintenance work: _____</p> <p>Signature and company stamp</p>	<p>Date of test and maintenance work: _____</p> <p>Signature and company stamp</p>

EC Declaration of conformity for machines (EC Directive 2006/42/EC)

The manufacturer **Eugen Lägler GmbH, Kappelrain 2, D-74363 Güglingen-Frauenzimmern, Germany**
 Tel.: 0049 - 7135 - 98 90-0 · Fax: 0049 - 7135 - 98 90-98
 E-Mail: info@laegler.com · http://www.laegler.com

certified herewith,
 that the machine

Generic denomination: **Floor sanding machine**
 Function: **Dry sanding of wooden floors, wooden stairs**
 Model: **ELAN**
 Serial number: **See type plate**
 Commercial name: **Edge-, stair- and corner sanding machine**

fulfils all the relevant provisions of the specified above European Directive.

The machine also fulfils all the relevant provisions of the European Directive
Electromagnetic Compatibility (2014/30/EU).

The following harmonized standards have been applied:

DIN EN ISO 12100: Safety of machinery - General principles for design - Risk assessment and risk reduction

DIN EN 60204-1: Safety of machinery - Electrical equipment of machines - Part 1

DIN EN 55014-1: Electromagnetic compatibility - Requirements for household appliances, electric tools and similar apparatus - Part 1

DIN EN 55014-2: Electromagnetic compatibility - Requirements for household appliances, electric tools and similar apparatus - Part 2

DIN EN 61000-3-2: Electromagnetic compatibility (EMC) - Part 3-2: Limits

DIN EN 61000-3-3: Electromagnetic compatibility (EMC) - Part 3-3: Limits

Technical file at: Eugen Lägler GmbH, Kappelrain 2
 D-74363 Güglingen-Frauenzimmern
 Germany

ELAN

Serial number: _____

Year of manufacture: _____