



English / Englisch

# Operating Instructions

Translation of original operating instructions  
for the edge-, corner- and stair-sanding machine

## FLIP®

**Lägler**  
www.laegler.com

00.320.20.002 01.09.2016



---

# CONTENTS



---

<b>1</b>	<b>Introduction.....</b>	<b>5</b>
1.1	Features of the machine .....	5
1.2	Description of the machine .....	5
1.3	Proper use as intended .....	5
1.4	Protective devices.....	6
1.5	Machine configuration.....	6
1.5.1	Basic equipment.....	6
1.5.2	Optional equipment.....	6
1.5.3	Wearing parts and safety-related parts .....	7
<b>2</b>	<b>Hazard warnings and safety instructions .....</b>	<b>8</b>
2.1	Hazard warnings.....	8
2.2	General safety instructions .....	12
<b>3</b>	<b>Technical data .....</b>	<b>14</b>
3.1	Data on type plate .....	14
3.2	Machine data .....	14
<b>4</b>	<b>Commissioning .....</b>	<b>16</b>
4.1	Preparing the machine.....	16
4.2	Connecting the power cable .....	17
4.3	Switching on the machine .....	18
4.4	Switching off the machine.....	19
<b>5</b>	<b>Working with the FLIP® .....</b>	<b>20</b>
5.1	General application tips.....	20
5.2	Replacing the sanding medium .....	22
5.2.1	Velcro sanding discs.....	22
5.2.2	Conventional sanding discs .....	23
5.3	Emptying the dust bag.....	24
<b>6</b>	<b>Transport and storage.....</b>	<b>27</b>
<b>7</b>	<b>Maintenance work and replacement of wearing parts .....</b>	<b>28</b>
7.1	Cleaning and care.....	29
7.2	Tightening the V-belt.....	30
7.3	Replacing the V-belt.....	31
7.3.1	Removing the V-belt.....	31
7.3.2	Installing the V-belt.....	32
7.4	Replacing the complete sanding plate.....	33
7.5	Replacing the motor pulley.....	34
7.6	Replacing the carbon brushes .....	36
7.7	Checking the dust suction system .....	37
7.8	Adjusting the guide rollers .....	38
7.8.1	Standard setting .....	38
7.8.2	Setting for special cases.....	40
7.9	Replacing the wheels and the guide rollers .....	41
7.9.1	Replacing the wheels .....	41
7.9.2	Replacing the guide rollers .....	41
7.10	Adjusting the wall-protecting roller .....	42
7.11	Replacing the wall-protecting roller .....	43

## CONTENTS

<b>8</b>	<b>Regular inspection and maintenance work in accordance with accident prevention regulations .....</b>	<b>44</b>
<b>9</b>	<b>Causes of faults .....</b>	<b>46</b>
9.1	The machine does not run or has switched off automatically.....	46
9.2	The machine attempts to start up but is not able to do so.....	47
9.3	The machine runs but has no or very little sanding power capacity.....	47
9.4	The machine vibrates intensely and runs noisily.....	48
9.5	The machine runs but creates a great deal of dust.....	48
9.6	Sanding problems (waves, strips, grooves).....	49
<b>10</b>	<b>Circuit diagram.....</b>	<b>51</b>
<b>11</b>	<b>Spare parts FLIP® .....</b>	<b>52</b>
<b>12</b>	<b>Service passport .....</b>	<b>63</b>
<b>13</b>	<b>EU Declaration of conformity for machines (EU Directive 2006/42/EC).....</b>	<b>64</b>

**Safety notes used in this operating instructions and their meaning:**

	<b><u>WARNING!</u></b>	<b>Death, severe physical injury or significant property damage</b> can occur if the corresponding cautionary measures are not taken!
	<b><u>CAUTION!</u></b>	<b>Moderate to light physical injury or property damage</b> can occur if the corresponding cautionary measures are not taken!
	<b><u>ATTENTION!</u></b>	An <b>undesired event</b> can occur if the corresponding instructions are not followed!

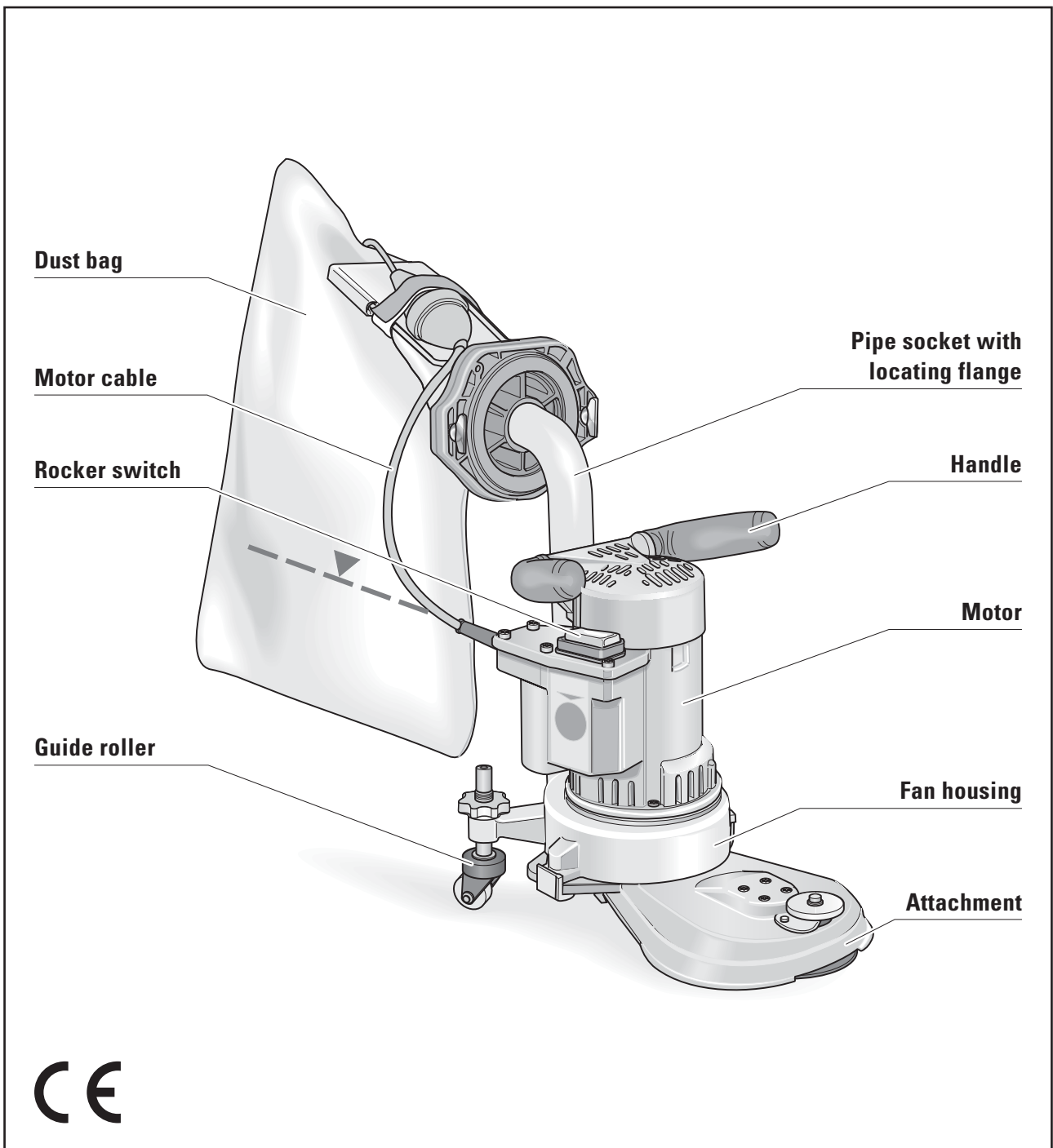

Fig. 1 Components of the edge-, corner- and stair-sanding machine FLIP®

# Introduction

## 1.1 FEATURES OF THE MACHINE

In figure 1 we have indicated the most important components of the FLIP®. Take your time to become familiar with the machine.

## 1.2 DESCRIPTION OF THE MACHINE

The FLIP® edge-sanding machine works with a sanding plate on which Velcro sanding discs can be fastened. Traditional sanding discs fastened with a tension screw can, of course, also be used. The work zone is protected by the attachment. The fan housing, on which the electric motor is mounted in vertical position, is located on the attachment. A motor power cable is used to connect the machine to the power supply system. The motor switch with ON/OFF positions is located on the switch box cover of the motor housing. The machine is moved by means of two guide rollers at the rear side of the machine. The handles are located on top of the motor. A rotatable pipe socket is mounted on the rear of the fan housing which feeds the sanding dust into the dust bag. The dust bag is connected to the pipe socket via a flange with two quick-release fasteners. The power cable is attached to the bag's fixing bracket with Velcro tape so that it is kept out of the working area of the machine.

There are three different attachments for the FLIP® (part numbers are in *Section 11, Spare parts FLIP®*):

- short attachment for sanding edges and stairs
- long attachment for sanding edges and below radiators or similar objects
- attachment for sanding corners (corner attachment)

## 1.3 PROPER USE AS INTENDED

The FLIP® edge-sanding machine is suitable for the dry sanding of wooden floors, cork floor and wooden stairs in the professional and rental business sectors.

**Any other form of use is not permitted without the approval of the manufacturer!**

**You have purchased a high-quality product from LÄGLER®. We wish you a great deal of success with your FLIP®. All LÄGLER® products are subjected to a thorough inspection before leaving the factory.**

**Please read these operating instructions completely before you begin working with your FLIP®. These operating instructions include important information on occupational safety and will provide you with answers to many questions so that you can work with the machine safely and without any problems. If you cannot find a specific subject in these operating instructions, please read the LÄGLER® application technique guidelines "Sanding of wooden floors" (<http://www.laegler.com>) or contact our service department, your retailer or your importer.**



### **WARNING!**

**RISK OF DEATH from electrical shock:**

**The machine may never be used for wet processing operations of any kind!**

---

## INTRODUCTION

---

### 1.4 PROTECTIVE DEVICES

---

The following parts of the machine are protective devices and thus must always be kept in perfect condition:

Attachment	= Protection against sanding disc and V-belt
Attachment cover	= Dust protection, protection against V-belt
Handle, motor housing, switch box cover	= Protection against current-carrying parts

### 1.5 MACHINE CONFIGURATION

---

#### 1.5.1 BASIC EQUIPMENT

---

- 1 Machine ready for operation
- 1 Operating instructions
- 1 Dust bag
- 1 Extension cable 3 x 1.5 mm<sup>2</sup> (3 x 0.0023 sq.in.), length 10 m (394")
- 1 Universal spanner Torx T25
- 1 Cotton bag
- 1 Emptying fixture
- 1 Waste bag
- 1 Cable tie
- 1 Velcro disc
- 1 Respiratory protection mask, filter class P3

#### 1.5.2 OPTIONAL EQUIPMENT

---

- Long attachment
- Corner attachment
- Foldable earmuff
- Working light FLIP®

**NOTE:**

You will find the corresponding part numbers for the optional equipment and wearing parts in *Section 11, Spare parts FLIP®*.

### 1.5.3 WEARING PARTS AND SAFETY-RELATED PARTS

---

Check the condition of the wearing parts and safety-related parts mentioned below at regular intervals in order to be able to work safely and optimally at all times.

Replace the following parts in case of wear and/or damage:

- Velcro coating on the sanding plate
- V-belt
- Motor pulley
- Sanding plate, complete
- Guide rollers
- Paper tensioning disc
- Screw for paper tension
- Carbon brushes
- Extension cable
- Motor cable
- Rocker switch
- Dust bag

# Hazard warnings and safety instructions



## **WARNING!**

### **RISK OF DEATH, RISK OF INJURY, RISK OF FIRE:**

- **Be certain to read the hazard warnings and safety instructions before using the machine!**
- **Instruct your co-workers and colleagues accordingly! Otherwise these persons could be exposed to danger or injured!**
- **Keep these hazard warnings and safety instructions in a safe place!**
- **Observe the applicable regulations and legal requirements in your country!**

## 2.1 HAZARD WARNINGS



## **WARNING!**

### **RISK OF DEATH from suffocation and RISK OF INJURY:**

- **Never** wrap the power cable around your neck or other parts of the body!

### **RISK OF DEATH from electrical shock:**

- The machine may **never** be used for wet processing operations of any kind!
- Do not expose the machine to rain! Do not use the machine in moist or wet environments!
- Do not connect the machine on hazardous electrical power sources! Only use safety sockets!
- All extensive maintenance work, especially on the electrical equipment, **must** be conducted by a qualified expert for safety reasons!
- The machine **must** be switched off and the power plug **must** be removed from the socket during all maintenance work and work on the electrical equipment!
- Avoid body contact with grounded parts, e.g. pipes, radiators, ovens, refrigerators!
- The quality of the motor cable and the power cables **must** match the quality of the original LÄGLER® cables!
- The motor cable and the power cables must be protected from mechanical and electrical damages in the workplace!
- Do not carry or pull by the machine by the cable! Do not pull on the cable to remove the plug from the socket! Protect the cable against heat, oil and sharp edges!

### **RISK OF DEATH from unsecured load:**

- When transported in a car or the like, the machines and all parts must be secured against sliding!



**WARNING!**

**RISK OF EXPLOSION due to sparks while sanding or a high dust concentration in the air:**

- Do not use the machine near
  - sources of fires,
  - flammable liquids or gases,
  - potentially explosive areas!
- Do not smoke in a dusty environment, e.g. while sanding or emptying the dust bag!

**RISK OF FIRE from sparks while sanding or from spontaneous combustion:**

- Prior to sanding a nailed or screwed floor all nails or screws must be countersunk deeply enough so that they cannot be sanded:
  - Countersink the nails for example with a hammer and a punch!
  - Tighten the screws!
- There is a high risk of fire when sanding woods with a large amount of resin, oiled or waxed floors or metal! Therefore, the machine must **always** be cleaned carefully directly after sanding! **Be certain** to note the warning notices of the manufacturers of paint, oil and wax!
- Cloths, pads, et cetera which have been immersed in oil or wax can spontaneously combust! **Be certain** to note the warning notices of the manufacturers of paint, oil and wax!
- The dust bag must **always** be removed from the machine **directly** after sanding and emptied into a waste bag with the emptying fixture! Dispose of these waste bags in a **non-combustible** container! Cover this container with a **non-combustible** cover (→ *Section 5.3, Emptying the dust bag*)!
- Always transport and store used dust bags in **closed** and **non-combustible** containers!
- Always transport and store the machine **without** dust bag!

**WARNING!****RISK OF FIRE from the overheating of the cable.**

- Only cables with two wires and wire cross-section of at least 1.5 mm<sup>2</sup> (0.0023 sq.in.) may be used as motor cables!
- Only cables with two or three wires and wire cross-section of at least 1.5 mm<sup>2</sup> (0.0023 sq.in.) may be used as power cables!
- The maximum cable length in order to connect the machine to the mains supply must not exceed 20 m (790")!

**HEALTH RISK caused by dust:**

- Make sure that the dust bag is properly fastened to the machine!
- Do not use damaged, washed or repaired dust bags!
- Do not work with an overfilled dust bag (→ *Section 5.3, Emptying the dust bag!*)
- If the machine is operated **correctly**, the mandatory dust emission values will not be exceeded! When emptying the dust bag, it is advisable to wear a respiratory protective mask at least filter class P2!
- A respiratory protective mask (at least filter class P2) must be worn when conducting other work that creates dust, e.g. cleaning of the machine!

**CAUTION!**

**RISK OF INJURY and RISK OF PROPERTY DAMAGE from rotating tools and parts of the machine:**

- For all operating conditions of the machine only one operator is required. As a consequence, for safety reasons only **one person** must be in the working area while operating the machine!
- Before switching on the machine, make sure that all tools and adjustment tools have been removed from the machine!
- The machine may not be started if the sanding plate is on the floor! Therefore, tip the machine backwards slightly to start the machine (→ *Section 4.3, Switching on the machine*)!
- **Never** leave the operational machine unattended!
- Do not reach into rotating tools or parts of the machine!
- Do not let children or other persons touch the machine or cables and keep them out of the work area!
- Do not wear any long articles of clothing or jewellery! These could be caught by moving parts!

**RISK OF INJURY and RISK OF PROPERTY DAMAGE from unintentional starting of the machine:**

- The power plug **must always** be removed from the socket when the machine is switched off!
- Make sure that on/off switch is not set to ON when connecting the machine to the mains supply!

**RISK OF INJURY and RISK OF PROPERTY DAMAGE from the rolling away, tipping or falling of the machine:**

- The machine must be secured against rolling away, tipping or falling when not in use!
- **Always** ensure that the machine is standing securely!

**RISK OF INJURY and RISK OF PROPERTY DAMAGE from unsuitable parts:**

- Only use tools, accessories and spare parts from LÄGLER® for the FLIP® (→ *Section 11, Spare parts FLIP®*)!  
**Warranty claims for foreign parts or damage caused thereby cannot be accepted!**

**CAUTION!****HEALTH RISK caused by noise:**

- Use hearing protection when conducting work that produces noise! Observe the applicable regulations and legal requirements in your country!

**RISK OF PROPERTY DAMAGE:**

- Do not store the unused machine with sanding media on the sanding plate! Otherwise the sanding media can cause scratches on the ground!
- Never conduct a maintenance or a replacement of wearing parts on the newly sanded wooden floor! Thus, you will avoid scratches or other damage to the floor!
- Improper transport will result in damage to the machine!

## 2.2 GENERAL SAFETY INSTRUCTIONS

---

- **Check your machines for damage!**

Before using the machines, you must inspect the safety devices carefully to ensure that they are working perfectly and as intended.

Check whether the moving parts are working properly, that they are not sticking, that no parts are broken, whether all parts are in perfect condition and installed properly and whether all other conditions which could influence the operation of the machine are in order.

Damaged safety devices and parts must be properly repaired or replaced by an authorized service shop insofar as nothing to the contrary is indicated in the operating instructions.

Regularly inspect the motor cable and have it replaced by a qualified electrician if it is damaged. Inspect the extension cable regularly and replace it if it is damaged (part number in *Section 11, Spare parts FLIP®*).

Damaged electrical components must be replaced by a qualified electrician (part number in *Section 11, Spare parts FLIP®*).

Do not use the machine if it cannot be switched on and/or switched off by using its switch.

- **Maintain your machines with care!**
  - Keep your machines clean so that you can work better and more safely.
  - Follow the maintenance guidelines and the instructions for replacing tools.
  - Keep the handles dry and free of oil and grease.
  
- **Provide good illumination in the workplace!**

Well lit construction sites reduce the risk of injury and allow you to better evaluate the quality of your work.
  
- **Keep your work area tidy!**

Untidy work areas create a risk of accidents.
  
- **Use the proper machines!**

Do not use low-performance machines or additional devices for heavy jobs. Do not use the machine for purposes and work that it is not intended for.
  
- **Do not overload the machine!**

It works better and more safely in the power range noted.
  
- **Do not bend too far over the machine!**

Avoid unnatural postures. Make sure that you stay in a stable position and keep your balance at all times.
  
- **Be attentive!**

Pay attention to your work. Work carefully and do not use the machine if you are not concentrating.
  
- **Store your machines safely!**

Store your unused machines in a dry, closed location out of the reach of children!

# Technical data

## ATTENTION!

In order to receive the correct spare parts from us, please specify in inquiries and spare part orders always the serial numbers of your machines!

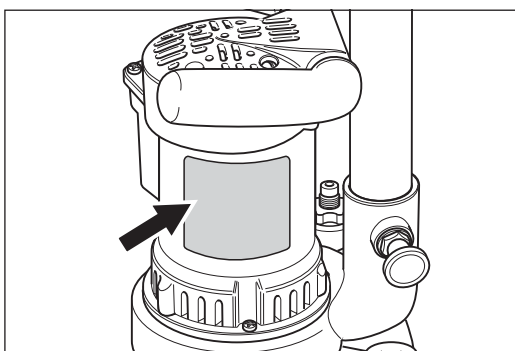

Fig. 2 Type plate on motor housing.

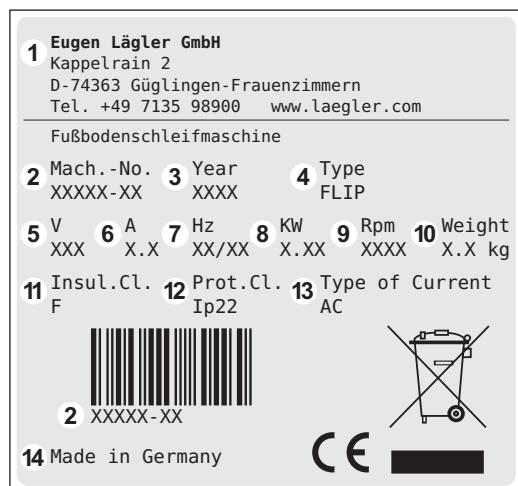

Fig. 3 Data on type plate.

## 3.1 DATA ON TYPE PLATE

The type plate of FLIP® is located on the motor housing (fig. 2). The following technical data are specified on the type plate (fig. 3):

- 1 Manufacturer
- 2 **Serial number of machine (Mach.-No.)**
- 3 Year of manufacture (Year)
- 4 Machine name (Type)
- 5 Required mains voltage in volt (V)
- 6 Current consumption in ampere (A)
- 7 Motor frequency in CPS (Hz)
- 8 Motor power in kilowatt (KW)
- 9 Motor speed in 1/min (Rpm)
- 10 Weight of machine in kg (Weight)
- 11 Insulation class (Insul. Cl.)
- 12 Protection class (Prot. Cl.)
- 13 Type of current
- 14 Country of manufacture

## 3.2 MACHINE DATA

Manufacturer	Eugen Lägler GmbH	
Machine type	edge-sanding machine	
Machine name	FLIP®	
Serial number	see type plate (fig. 2)	
Year of manufacture	see type plate (fig. 2)	
Motor type	universal motor	
Kind of current	alternating current (AC)	
Voltage	230 V	110 V
Frequency	50 / 60 Hz (CPS)	50 / 60 Hz (CPS)
Motor power	1.35 kW	
Necessary fuse protection of mains supply	at least 10 A	
Insulation class	F	

## TECHNICAL DATA

Protection class	IP 22
Protection system	2
Safety devices	no-voltage release, temperature switch as overload protection in the motor
Diameter of sanding disc - short and long attachment - corner attachment	150 mm (~ 5.9") 61 mm (~ 2.4")
Speed of sanding disc under load - short and long attachment - corner attachment	approx. 3100 1/min (rpm) approx. 7750 1/min (rpm)
Length - short attachment - long attachment - corner attachment	155 mm (~ 6.1") 315 mm (~ 12.4") 225 mm (~ 8.9")
Height - short and long attachment without wall-protecting roller - short and long attachment with wall-protecting roller - corner attachment	44 mm (~ 1.7") 58 mm (~ 2.3") 51.5 mm (~ 2")
Overall length of machine without dust bag - with short attachment - with long attachment - with corner attachment	460 mm (~ 18.1") 620 mm (~ 24.4") 530 mm (~ 20.9")
Overall height of machine without dust bag	460 mm (~ 18.1")
Overall width of machine	260 mm (~ 10.2")
Overall weight of machine	9,8 kg (21.6 lbs)
Dust emissions at workplace (measured as per the testing requirements GS-HO-15 of German statutory accident insurance DGUV)	< 0,2 mg/m <sup>3</sup> (0.0024 gr./cu.yd.)
Workplace-related noise emission values	84 dB(A)
Sound power level	95 dB(A)
Measurement uncertainty constant of the noise emission values	4 dB(A)
Vibration total value $a_{hv}$ (measured at the handle)	< 2.5 m/s <sup>2</sup>

NOTE on noise emission:

The values indicated are emission values and must not represent safe workplace values as well.

Although a correlation exists between emission levels and immission levels, it is not always possible to determine whether additional precautionary measures are required.

Factors that can have an effect on the immission level existing at the workplace include the duration of the effects, the characteristics of the work area and other sources of noise, e.g. the number of machines and processing operations in the vicinity. The permissible workplace values may also vary from country to country.

This information, however, is intended to enable the user to better estimate the dangers and risks.

# Commissioning

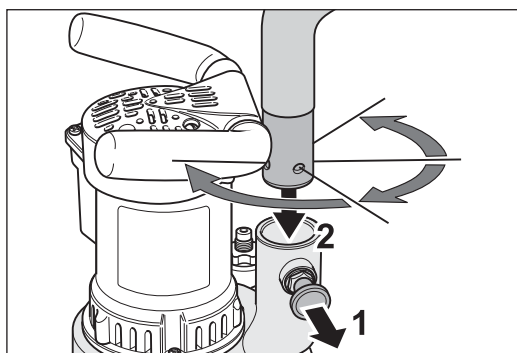

Fig. 4 Pull the stop bolt (1) and insert the pipe socket into the fan housing (2).

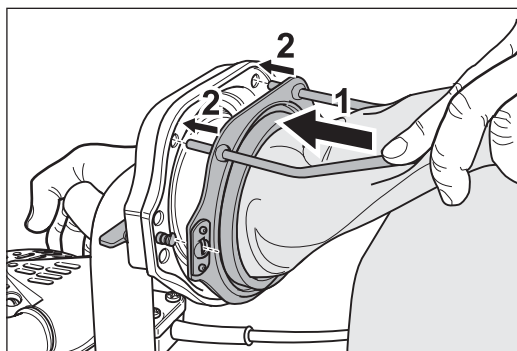

Fig. 5 Push the dust bag over the locating flange (1) and fix it in place with the two metal studs (2).

The section describes how to start using the FLIP® on-site. In order to prevent damage and malfunctions, you must proceed in the order of steps indicated below.

## 4.1 PREPARING THE MACHINE

### **ATTENTION!**

**Please note that the packaging serves as a transport container for the machine, accessories and the sanding medium! Furthermore, the machine can be sent back safely in the original packaging without risk should there be any problems!**

- 1 Unpack the machine carefully. Dispose of the packing materials according to the environmental regulations.
- 2 Pull out the stop bolt on the suction socket of the fan housing (fig. 4, 1) and at the same time insert the pipe socket into the fan housing (fig. 4, 2).
- 3 Turn the pipe socket so that the opening of the elbow piece is facing the back and the stop bolt can snap into place when it is let go.
- 4 The pipe socket can be turned 360°. Four fixed positions exist where the stop bolt can snap into place in the pipe socket.



### **CAUTION!**

#### **RISK OF INJURY and RISK OF PROPERTY DAMAGE:**

**The stop bolt must always snap into place in the pipe socket!**

- 5 Push the dust bag opening over the locating flange to the end of the elbow piece (fig. 5, 1). Fix the dust bag into place using the two metal studs (fig. 5, 2).



- 6 Attach the dust bag to the locating flange using the two quick-release fasteners (fig. 6).

## 4.2 CONNECTING THE POWER CABLE



### **WARNING!**

#### **RISK OF DEATH from electrical shock:**

- **Observe the applicable regulations and legal requirements in your country!**

#### **RISK OF FIRE from the overheating of the cables:**

- **The maximum cable length in order to connect the machine to the mains supply must not exceed 20 m (790")!**
- **Only cables with two wires and wire cross-section of at least 1.5 mm<sup>2</sup> (0.0023 sq.in.) may be used as motor cables!**
- **Only cables with two or three wires and wire cross-section of at least 1.5 mm<sup>2</sup> (0.0023 sq.in.) may be used as power cables!**

- 1 Insert the plug of the motor cable in the coupler of the extension cable (fig. 7).
- 2 Attach the extension cable coupler to the dust bag using the Velcro loop (fig. 8).
- 3 Insert the extension cable into a sufficiently protected power socket.

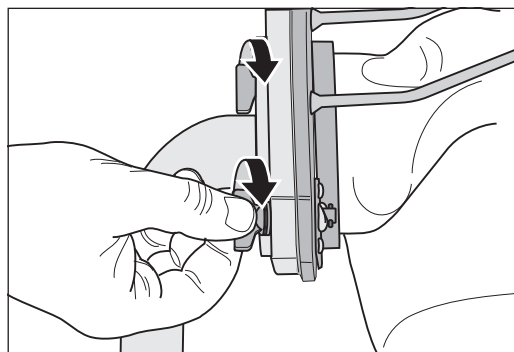

Fig. 6 Secure the dust bag using the quick-release fasteners.

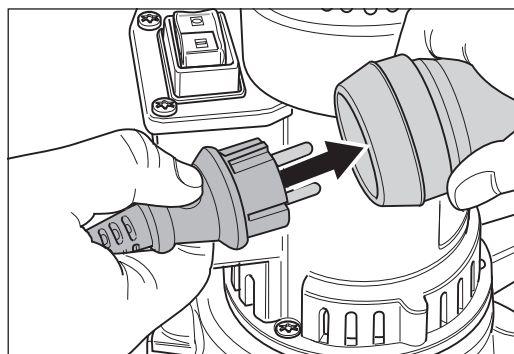

Fig. 7 Connect the motor cable to the extension cable.

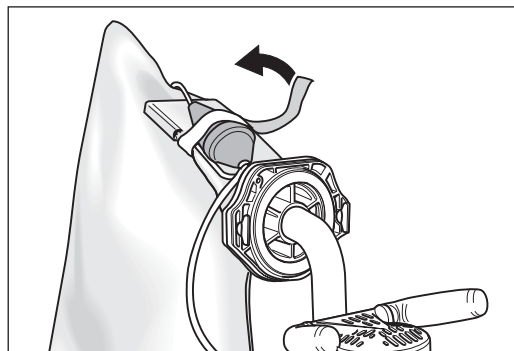

Fig. 8 Attach the extension cable coupler to the dust bag.

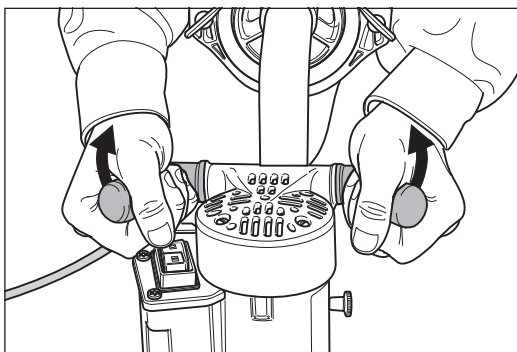

Fig. 9 Tilt the machine backwards slightly before starting and switching off the machine.

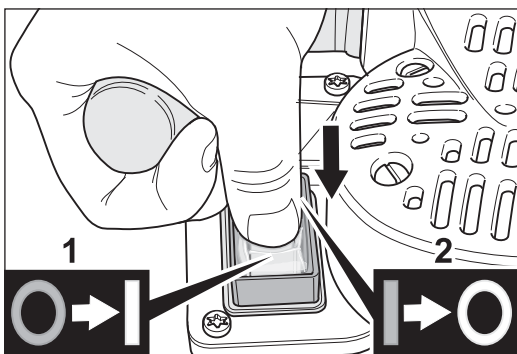

Fig. 10 Start (1) and switch off (2) the machine using the rocker switch.

### 4.3 SWITCHING ON THE MACHINE



#### **CAUTION!**

**RISK OF INJURY and RISK OF PROPERTY DAMAGE from rotating parts of the machine:**

- **Always** tip the machine backwards slightly (fig. 9) before starting the machine so that the sanding disc is raised off the floor!
- **Never** allow the machine to run unattended!

- 1 Tip the machine backwards slightly (fig. 9)!
- 2 Flip the rocker switch to "I" (fig. 10, 1). The switch button will snap into the place and the motor will be started.
- 3 Tip the machine forward and begin sanding (→ *Section 5, Working with the FLIP®*).



#### **CAUTION!**

**RISK OF PROPERTY DAMAGE:**

If the switch button does not snap into switch position "I", do not continue sanding! Otherwise the motor can be permanently damaged!

**Remedy the following causes for the malfunction:**

- The electrical network has undervoltage! Use a transformer if necessary.
- The extension cable is too long (longer than 20 m or the cable cross-sections of the extension cable are smaller than 1.5 mm<sup>2</sup>!
- The carbon brushes of the motor have reached their wear limit and must be replaced (→ *Section 7.6, Replacing the carbon brushes*)!
- The switch is defective! It must be replaced by a qualified electrician (→ *Section 10, Circuit diagram*)!

#### 4.4 SWITCHING OFF THE MACHINE

**CAUTION!**

**RISK OF INJURY and RISK OF PROPERTY DAMAGE from rotating parts of the machine:**

**Always tip the machine backwards slightly (fig. 9) before switching off the machine so that the sanding disc is raised off the floor!**

- 1 Tip the machine backwards slightly (fig. 9)!**
- 2 Flip the rocker switch to "0" (fig. 10, 2). The switch button will snap into the place and the motor will be switched off.
- 3 Wait until the sanding plate comes to a complete stop before stand the machine back on the sanding plate!**

**CAUTION!**

**RISK OF INJURY and RISK OF PROPERTY DAMAGE:**

**Always remove the power plug from the socket after you have switched off the machine!**

**ATTENTION!**

**Do not store the unused machine with sanding media on the sanding plate! Otherwise the sanding media can cause scratches on the ground!**

# Working with the FLIP®

## NOTE:

For more information free of charge, please contact: within Germany

- Telephone: 0800 / 52 34 537

- Fax: 0800 / 48 66 353

within the USA

- Telephone: 800-848-6635

or

- Telephone: 0049 - 7135 - 98 90 - 0

- Fax: 0049 - 7135 - 98 90 - 98

- e-mail: info@laegler.com

- Internet: <http://www.laegler.com>

You will also find important and interesting application tips in the LÄGLER® application technique guidelines "Sanding of wooden floors" (<http://www.laegler.com>)!

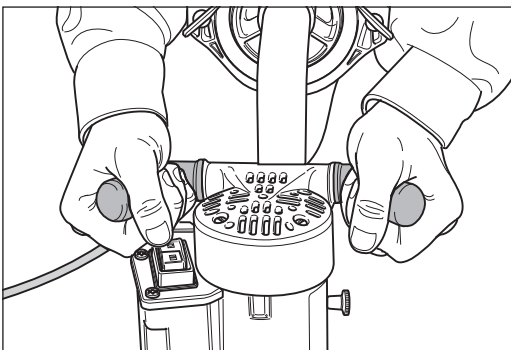

Fig. 11 Guide the FLIP® with both hands.

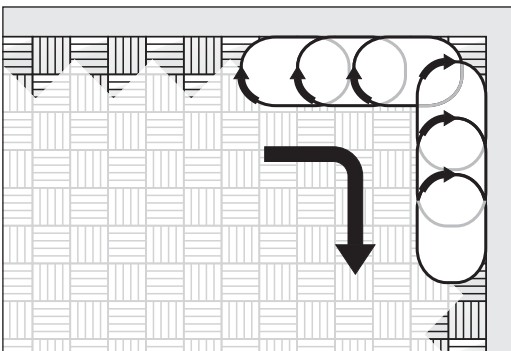

Fig. 12 FLIP® with **short** or **long** attachment:  
Rotary **clockwise** movements!

## 5.1 GENERAL APPLICATION TIPS



### **WARNING!**

#### **RISK OF DEATH from electrical shock:**

The machine may **never** be used for wet processing operations of any kind!

### **ATTENTION!**

- **Bear in mind that the FLIP® operates at very high cutting speeds! For this reason, there is a risk of burn marks for finer grit grades!**
- **Do not apply excessive pressure to the attachment while sanding! Excessive pressure will significantly worsen the sanding finish by causing deep scratches or burn marks and could cause the motor to switch off from overheating!**

The FLIP® is used for the dry sanding of edges, corners and stairs. The attachment can be changed in a matter of seconds (➔ *Section 7.3.1, Removing the V-belt, step 1 to 6* and *Section 7.3.2, Installing the V-belt, step 5 to 8*).

- The FLIP® with **short** or **long** attachment is handled with rotary **clockwise** movements (fig. 12) during the sanding process!
- The FLIP® with **corner** attachment is handled with **counterclockwise** movements (fig. 13) during the sanding process! Otherwise deep sanding marks might be generated which could be removed by a very time-consuming procedure afterwards only!
- Deep sanding marks due to the selection of a too coarse grit grade can be prevented by starting the first sanding operation with the finest grit grade possible.
- Prevent sanding marks made by previously used grit grade by adhering to the order of the sandpaper grit grade and never skip more than one grit grade.

- After replacing the sanding disc, start working in poorly lit areas of the room in order to remove the initial aggressiveness of the sanding medium.
- Vacuum the floor thoroughly always directly **before each** workstep (every sanding step, gap filling or surface treatment).
- Clean the wheels of the machine regularly.

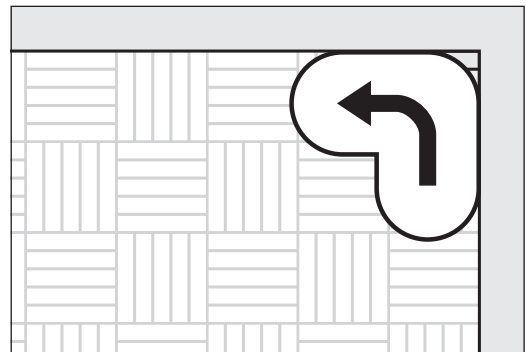

Fig. 13 FLIP® with **corner attachment**:  
Direction of movements is **counterclockwise!**

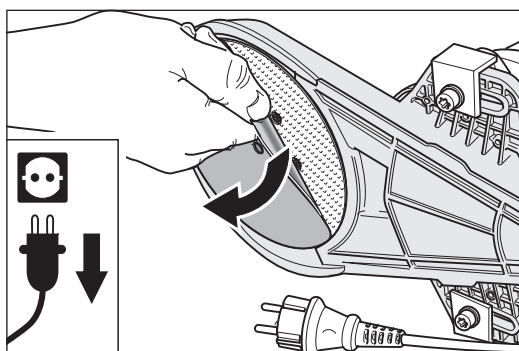

Fig. 14 Remove the Velcro sanding disc from the sanding plate.

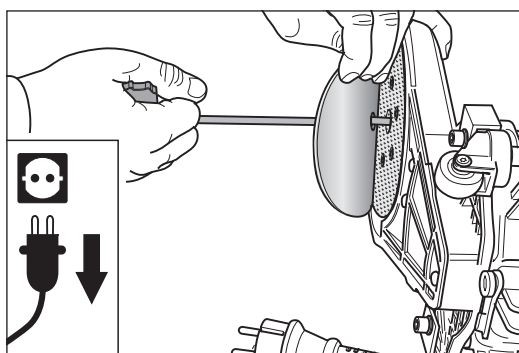

Fig. 15 Mount the new Velcro sanding disc in a centred position and press down.

## 5.2 REPLACING THE SANDING MEDIUM

### ATTENTION!

- **Only use sanding discs with paper as the base! Do not use any sanding discs with thick bases such as fibre discs, cutting discs or similar materials! Otherwise the sanding plate will be damaged!**
- **Do not use any double sanding discs (with sanding grit on both sides)! Otherwise the Velcro coating on the sanding plate will be damaged!**
- **Always use only one sanding disc! Otherwise the sanding results will not be satisfactory and the dust suction system will not be fully operational!**
- **You will receive the best sanding finish and price/performance ratio with the Velcro sanding discs from LÄGLER®!**

Depending on the material being sanded, you will use various sandpaper grit grades. Proceed as follows to change the sanding medium:

### 5.2.1 VELCRO SANDING DISCS

- 1 **Switch off the machine and pull the power plug out of the socket!**
- 2 Lay the machine on its side, avoiding damage to the floor and the machine!
- 3 Pull the worn-out Velcro sanding disc off of the sanding plate (fig. 14).
- 4 Place a new Velcro sanding disc on the sanding plate. The Velcro sanding disc must be positioned in the centre of the sanding plate. The hole in the centre of the sanding disc and the universal spanner make this step easier (fig. 15).
- 5 Press the Velcro sanding disc onto the sanding plate.

## 5.2.2 CONVENTIONAL SANDING DISCS

- 1 **Switch off the machine and pull the power plug out of the socket!**
- 2 Lay the machine on its side, avoiding damage to the floor and the machine!
- 3 Use the universal spanner to remove the screw from the sanding plate (fig. 16).
- 4 Remove the screw and paper tensioning disc (fig. 17, 1). Remove the sanding disc from the sanding plate (fig. 17, 2) and put all three parts aside.
- 5 Put on a new sanding disc and insert the screw with the paper tensioning disc into the hole of the sanding plate (fig. 18, 1).
- 6 Turn the screw in the sanding plate with the universal spanner (fig. 18, 2). Make sure that the sanding disc is as centred as possible on the sanding plate.
- 7 Tighten the screw with the universal spanner until it is hand-tight.

**ATTENTION!**

**Do not tighten the screw for attaching the sanding disc too tightly! The thread of the sanding plate could otherwise be damaged!**

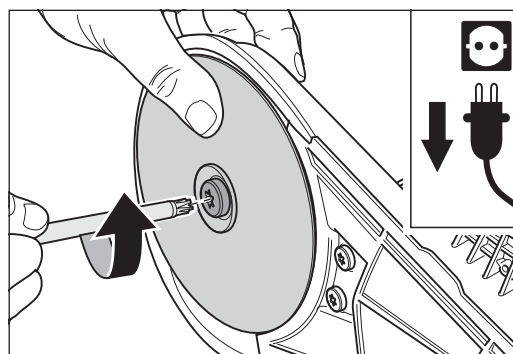

Fig. 16 Remove the screw with the universal spanner.

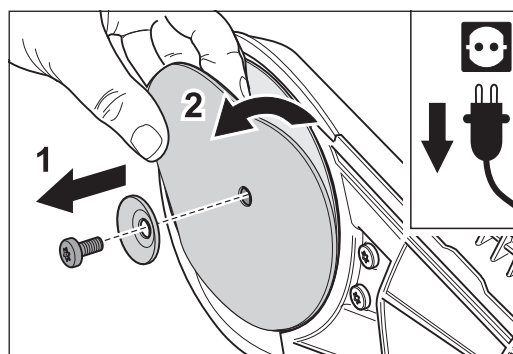

Fig. 17 Remove the screw and the paper tensioning disc (1) and remove the sanding disc (2).

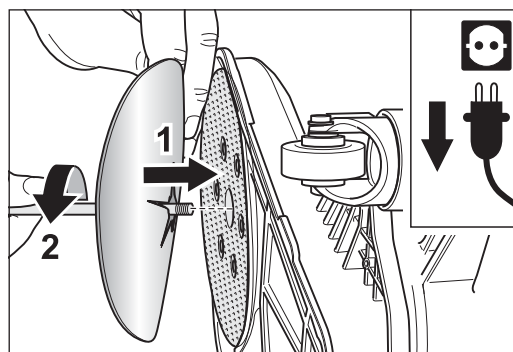

Fig. 18 Mount the new sanding disc (1) and tighten the screw (2).

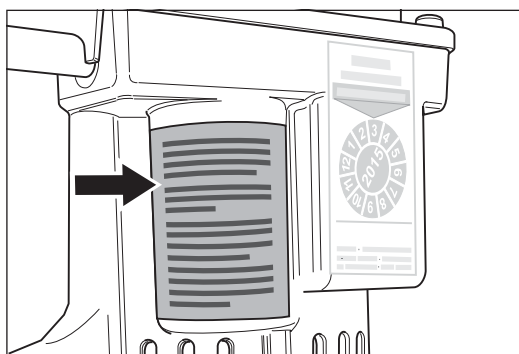

Fig. 19 Note the warning on the motor housing!

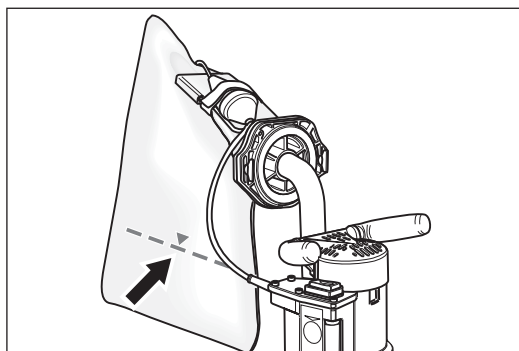

Fig. 20 The horizontal line marks the maximum fill level of the dust bag.

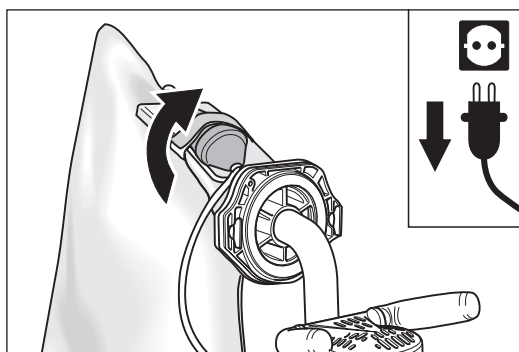

Fig. 21 Remove the coupler from the Velcro loop on the dust bag.

### 5.3 EMPTYING THE DUST BAG



#### **WARNING!**

#### **RISK OF FIRE from the formation of sparks while sanding:**

- **Note the warning on the motor housing (fig. 19)!**
- **The dust bag must always be removed from the machine directly after sanding and emptied into a waste bag with the emptying fixture! Dispose of these waste bags in a non-combustible container! Cover this container with a non-combustible cover (fig. 32)!**
- **Always transport and store used dust bags in closed and non-combustible containers!**

#### **HEALTH RISK caused by dust:**

**In order to ensure that the dust values in the air do not exceed the prescribed threshold levels, please note:**

- **The dust bag must be emptied when it is one-third full at the very latest in order to prevent a deterioration of the suction performance due to the lack of filtering surface area! The horizontal line on the outside of the dust bag marks the maximum fill level (fig. 20)!**
- **Do not work with an overfilled dust bag!**
- **Do not wash, patch or repair the dust bag in any other manner!**
- **Damaged dust bags must be replaced with new ones!**
- **When emptying the dust bag, wearing a respiratory protective mask (at least filter class P2) is recommended!**

In order to empty the dust bag in a manner as free from dust as possible, an emptying fixture, a waste bag and cable tie are included with the FLIP®.

Proceed as follows to empty the dust bag:

- 1 **Switch off the machine and pull the power plug out of the socket!**
- 2 Remove the extension cable coupler from the Velcro loop on the dust bag (fig. 21).



- 3 Remove the plug of the motor cable from the extension cable coupler.
- 4 Shake the dust residue from the machine into the dust bag (fig. 22).
- 5 Open the quick-release fasteners on the locating flange (fig. 23, 1).
- 6 Slowly pull the dust bag off of the locating flange (fig. 23, 2).
- 7 Hold the handle of the emptying fixture and insert a waste bag from the ribbed side through the opening in the centre of the fixture (fig. 24).
- 8 Pull the waste bag over the emptying fixture from behind (fig. 25).
- 9 Take hold of the emptying fixture with the waste bag in one hand and take hold of the dust bag in the other. Hold the dust bag at a slight angle to prevent dust from escaping.
- 10 Insert the dust bag with fixing plate into the emptying fixture. Make sure that the dust bag rods are in the correct position: The pins must fit into the openings provided (fig. 26).
- 11 Apply light pressure to insert the fixing plate of the dust sack completely into the emptying fixture. The pins on the dust bag rods will pierce the waste bag and prevent it from slipping (fig. 26).

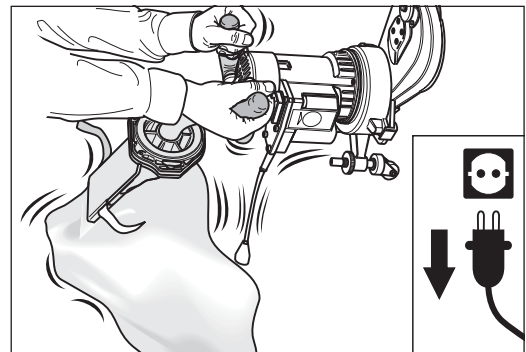

Fig. 22 Shake the dust residue from the machine into the dust bag.

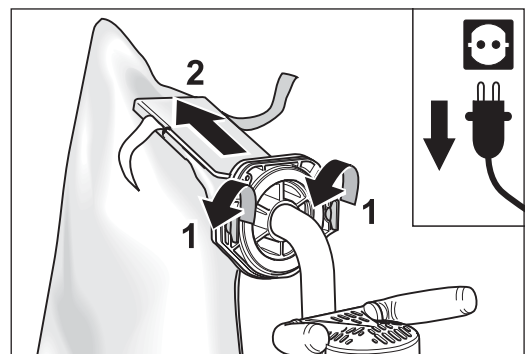

Fig. 23 Open both quick-release fasteners (1) and remove the dust bag (2).

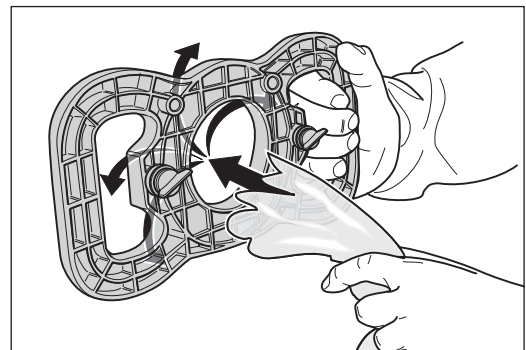

Fig. 24 Insert the waste bag into the emptying fixture.

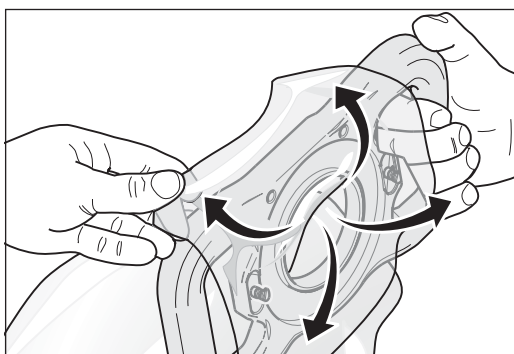

Fig. 25 Pull the waste bag over the fixture.

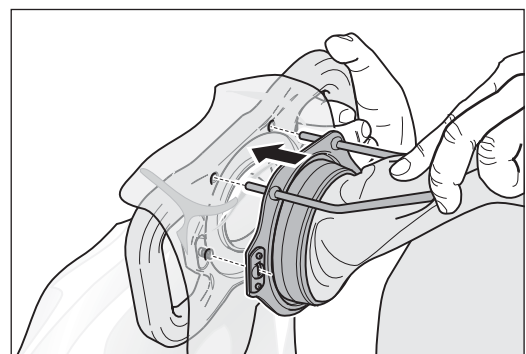

Fig. 26 Insert the dust bag with fixing plate into the emptying fixture.

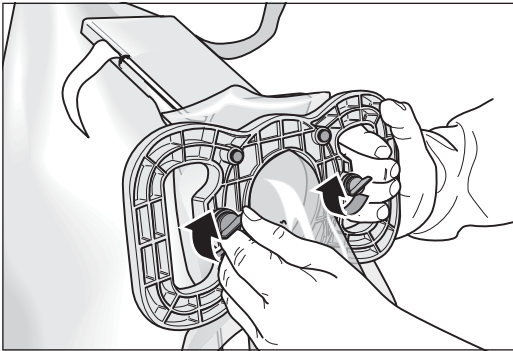

Fig. 27 Attach the emptying fixture to the dust bag.

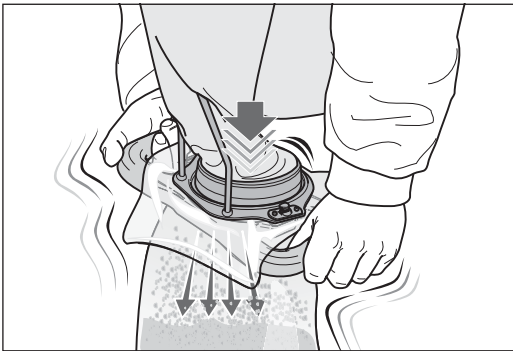

Fig. 28 Empty the dust bag by shaking it vigorously.

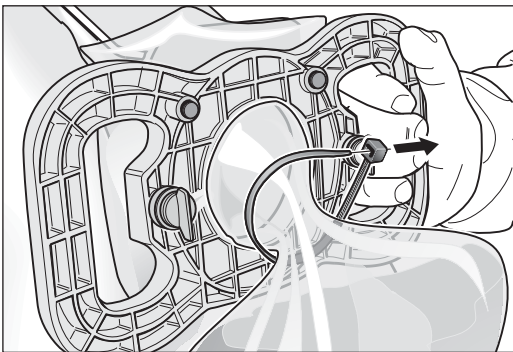

Fig. 29 Seal the waste bag with a cable tie.

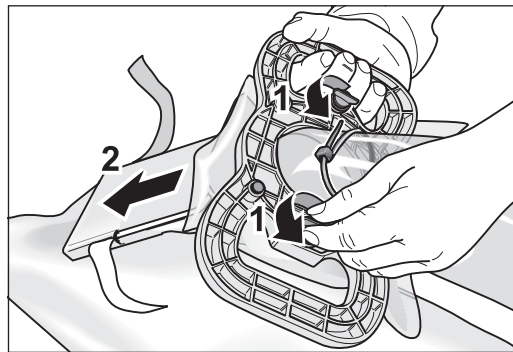

Fig. 30 Open the quick-release fasteners (1) and remove the dust bag (2).

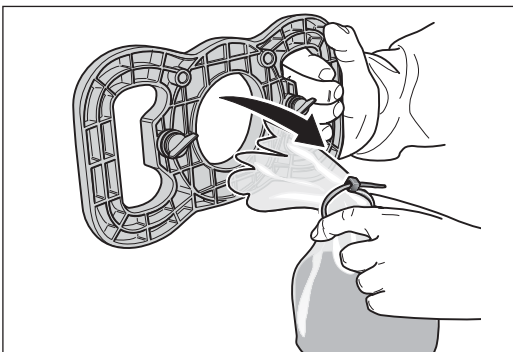

Fig. 31 Remove the waste bag from the emptying fixture.

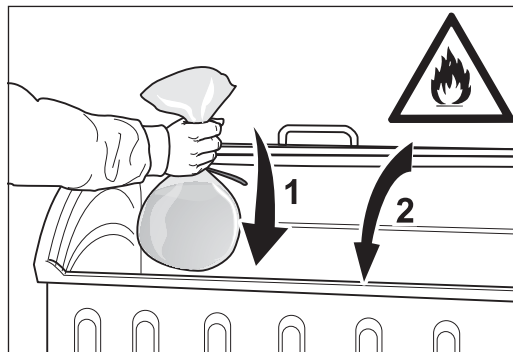

Fig. 32 Throw the filled waste bag into a **non-combustible** container (1) and keep this closed (2) → **risk of fire!**

- 12 Attach the emptying fixture to the dust bag by turning the two quick-release fasteners 90° clockwise (fig. 27).
- 13 Emptying the dust bag into the waste bag by shaking it vigorously (fig. 28).
- 14 Seal the filled waste bag with a cable tie (fig. 29).
- 15 Keep the dust bag tilted at a slight angle for the residual dust to fall back into the dust bag and open the two quick-release fasteners on the emptying fixture (fig. 30, 1).
- 16 Remove the emptying fixture from the dust bag (fig. 30, 2).
- 17 Reattach the dust bag to the machine in the reverse order (→ *Section 4.1, Preparing the machine*).
- 18 Remove the filled waste bag from the emptying fixture (fig. 31) and place it in a **non-combustible** container (fig. 32)! Due to the **risk of fire**, seal the container with a **non-combustible** cover!

# Transport and storage



## **WARNING!**

### **RISK OF INJURY and RISK OF PROPERTY DAMAGE:**

**In the event of transport in an automobile or similar the machine and all parts must be secured against sliding!**

### **RISK OF FIRE from the formation of sparks while sanding:**

**Always transport and store the machine without the dust bag! Store used dust bags in closed and non-combustible containers!**

### **RISK OF FIRE from spontaneous combustion:**

**Oil or wax can lead to spontaneous combustion! Therefore, the machine must always be cleaned carefully before transport or storage!**

If the machine must be stored for a longer period of time, take the measures necessary to ensure dry and frost-free storage with minimum temperature fluctuations.

In order for the FLIP® to need less space for transport or storage, proceed as follows:

- 1 Pull out the stop bolt in the fan house (fig. 33, 1).
- 2 At the same time, turn the pipe socket until the dust bag is positioned over the attachment (fig. 33, 2) and the stop bolt noticeably snaps into place in the pipe socket when released (fig. 33, 3).



## **CAUTION!**

### **RISK OF INJURY and RISK OF PROPERTY DAMAGE:**

**The stop bolt must always snap into place in the pipe socket!**

- 3 You can easily carry the machine using the pipe socket (fig. 34).

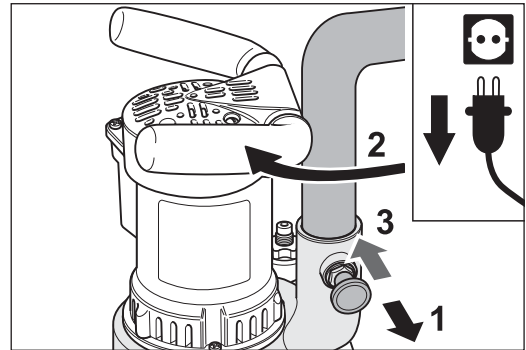

Fig. 33 Pull out the stop bolt (1) and simultaneously turn the pipe socket (2). Then release the stop bolt (3). It **must** snap into place in the pipe socket!

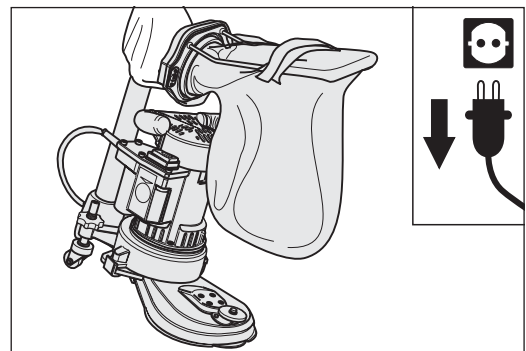

Fig. 34 Carry the FLIP® by the pipe socket.

## **NOTE!**

You can use parts of the transport packing to transport or store the machine!

# Maintenance work and replacement of wearing parts



## **WARNING!**

**RISK OF DEATH from electrical shock and RISK OF INJURY from rotating machine parts:**

- **All extensive maintenance work, especially on the electrical equipment, must be conducted by a qualified expert for safety reasons!**
- **All maintenance work must be conducted with the machine switched off and with the power plug removed from the socket!**

## **ATTENTION!**

- **Only use original spare parts from LÄGLER®! This is the only way to ensure that your machine continues to perform! Warranty claims for third-party parts will not be honoured!**
- **Never conduct the maintenance work and replacement of wearing parts on the newly sanded wooden floor! You could cause scratches or other damage to the floor!**
- **Do not use any cleaning products which contain solvents!**

From time to time, at the latest when damages are discovered, you must conduct various maintenance tasks and replace wearing parts. Work in a clean, well lit location and work according to these operating instructions. You will find the tool needed to be able to conduct the following work in the tool bag.

An inspection of the machine can be conducted quickly and prevents the necessity of later complaints which can be caused by small damages to the machine or by worn-out parts. These measures contribute significantly to the preservation of the value of the machine and, ultimately, to your own safety.

## 7.1 CLEANING AND CARE

**WARNING!**

**RISK OF FIRE from the formation of sparks while sanding or from spontaneous combustion:**

- **There is a high risk of fire when sanding woods with a large amount of resin, oiled or waxed floors or metal! Therefore, the machine must always be cleaned carefully directly after sanding!**
- **Be certain to note the warning notices of the paint, oil and wax manufacturers!**

The following maintenance measures should be conducted before beginning work to ensure the proper functionality of the machine and the usual first-class sanding results.

- Clean the wheels of the machine.
- Check the tension of the V-belt and correct this if necessary (➔ *Section 7.2, Tightening the V-belt*).
- Clean the paper tensioning screw and the thread of the sanding plate regularly. Otherwise the thread will be damaged.
- Check the dust suction system and the dust bag for leaks and damages.
- Conduct a visual inspection of the electrical equipment (rocker switch, extension cable, plug, couplers).

Following restoration tasks, residual material consisting of adhesive, wax or sealing lacquer may have accumulated in the pulleys or in the attachment.

This can impair the running characteristics of the machine and reduce the suction performance. This kind of soiling is indicated in most cases by unsteady running, difficult starting, reduced working speed and increased development of noise. The suction performance also decreases. In this case, the V-belt must be removed (➔ *Section 7.3.1, Removing the V-belt*) and the attachment and flanks of the pulley must be cleaned. Check whether there are any deposits in the fan housing or on the fan blades and remove these if necessary. Wear a respiratory protective mask.

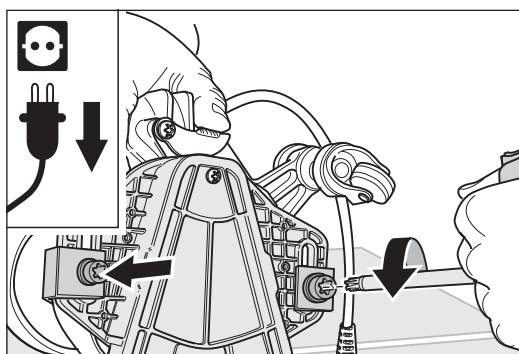

Fig. 35 Undo the two screws that connect the attachment.

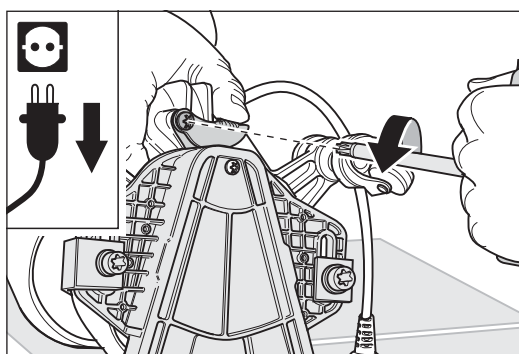

Fig. 36 Undo the screw which attaches the belt tightening plate.

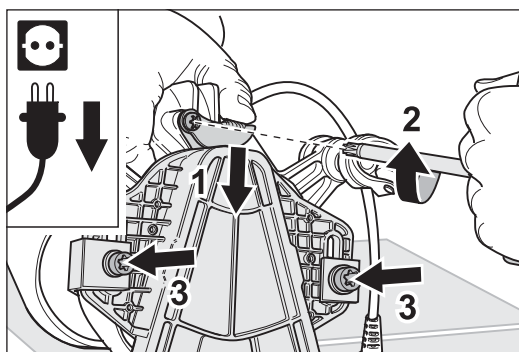

Fig. 37 Hold the FLIP® by the fan housing, press on the belt tightening plate (1) and retighten the three screws (2 and 3).

## 7.2 TIGHTENING THE V-BELT

### **ATTENTION!**

**Do not overtighten the V-belt! This will allow you to avoid excessive wearing of the V-belt and pulleys!**

The V-belt must be retightened from time to time. To do so, proceed as follows:

- 1 **Switch off the machine and pull the power plug out of the socket!**
- 2 Lay the machine on its side or with the motor housing on a table. Avoid damages to the floor or table and the machine.
- 3 Use the universal spanner to undo the two screws which connect the attachment to the fan housing (fig. 35).
- 4 Use the universal spanner to undo the screw which attaches the belt tightening plate (fig. 36).
- 5 Hold the FLIP® by the fan housing and press the belt tightening plate forward towards the attachment at the same time with your thumb (fig. 37, 1). Use your other hand and the universal spanner to retighten the three screws (fig. 37, 2 and 3).



### 7.3 REPLACING THE V-BELT

Use only original LÄGLER® V-belts (part number in *Section 11, Spare parts FLIP®*)!

The V-belt must be replaced, at the latest, when it cannot be retightened because the screws for connecting the attachment are at the end of the holes.

#### 7.3.1 REMOVING THE V-BELT

- 1** Switch off the machine and pull the power plug out of the socket!
- 2** Lay the machine on its side or with the motor housing on a table. Avoid damages to the floor or table and the machine.
- 3** Undo the screw of the belt tightening plate with the universal spanner (fig. 38, 1).
- 4** Turn the belt tightening plate away from the attachment (fig. 38, 2). and retighten the screw of the belt tightening plate (fig. 38, 3).
- 5** Use the universal spanner to remove the two screws which connect the attachment, along with the washers and the guide angles (fig. 39). Place these parts to the side.
- 6** Remove the attachment from the machine (fig. 40) and put down the attachment with the sanding disc facing upward.
- 7** Use the universal spanner to undo the fixing screws of the attachment cover and remove this from the attachment (fig. 41).
- 8** Turn the attachment over.

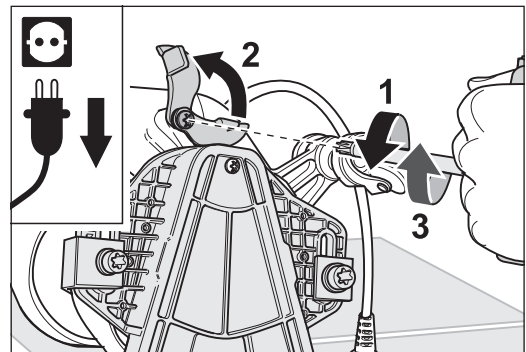

Fig. 38 Loosen the screw (1), turn the belt tightening plate away from the attachment (2) and retighten the screw (3).

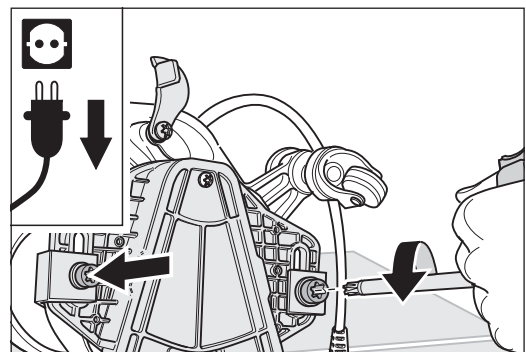

Fig. 39 Remove the two screws which connect the attachment, along with the washers and the guide angles.

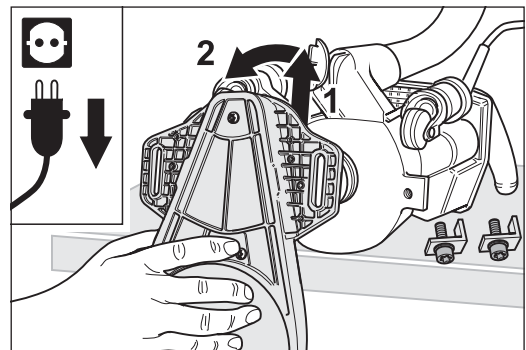

Fig. 40 Remove the attachment from the machine.

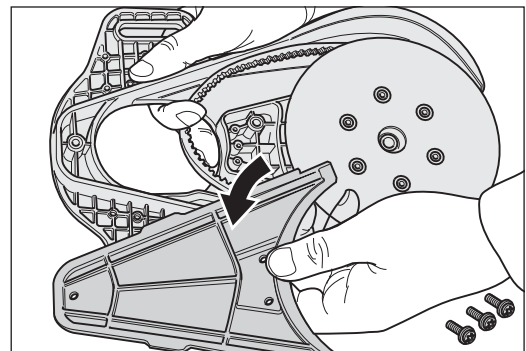

Fig. 41 Remove the attachment cover from the attachment.

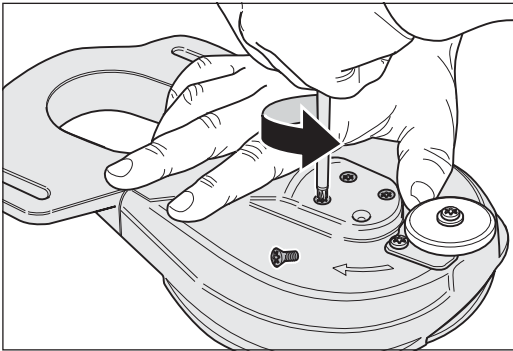

Fig. 42 Remove the four fixing screws of the complete sanding plate.

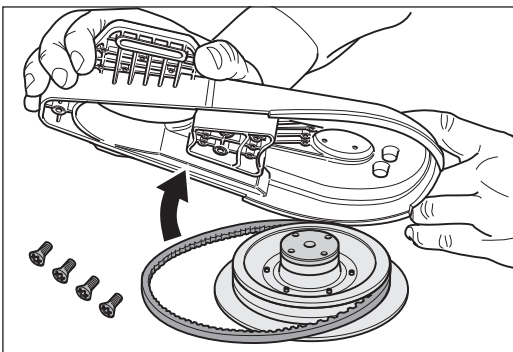

Fig. 43 Remove the attachment from the complete sanding plate.

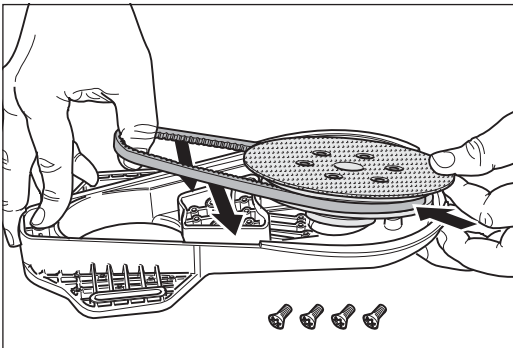

Fig. 44 Insert the complete sanding plate with the V-belt into the attachment. Make sure that the holes of the complete sanding plate are aligned with the holes in the attachment!

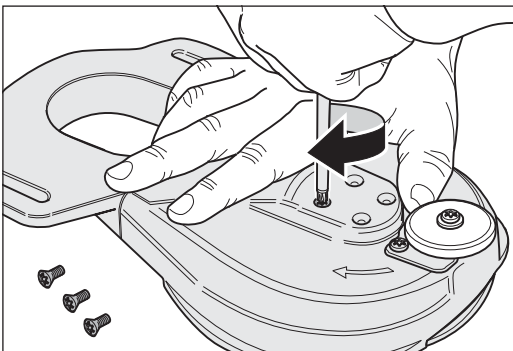

Fig. 45 Tighten the four screws for attaching the complete sanding plate.

- 9 Use the universal spanner to undo the four fixing screws of the complete sanding disc (fig. 42).
- 10 Remove the attachment from the complete sanding disc (fig. 43).
- 11 Dispose of the worn-out V-belt.
- 12 Check whether the sanding plate pulley or the motor pulley are worn-out. Replace these parts if necessary (→ Section 7.4, Replacing the complete sanding plate and Section 7.5, Replacing the motor pulley).
- 13 Clean the two pulleys and the attachment. Wear a respiratory protective mask if necessary.

### 7.3.2 INSTALLING THE V-BELT

- 1 Place the new V-belt on the complete sanding plate pulley.
- 2 Insert the complete sanding plate with V-belt in the attachment. Ensure that the holes of the complete sanding plate are aligned with the holes in the attachment (fig. 44)!
- 3 Make sure that the sanding plate can be turned by hand and that the V-belt is correctly placed in the attachment.
- 4 Turn the attachment over and tighten the four screws for attaching the complete sanding plate using the universal spanner (fig. 45).
- 5 Push the attachment over the motor pulley and insert the V-belt into the motor pulley (fig. 46).
- 6 Put on the attachment cover.

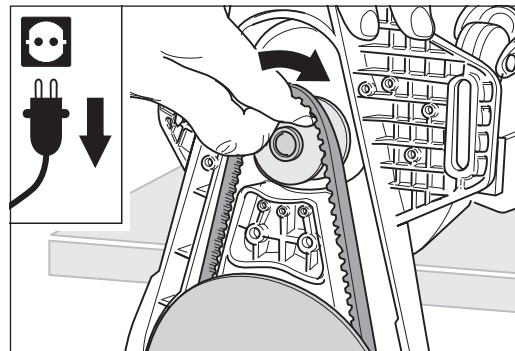

Fig. 46 Insert the V-belt into the motor pulley.



- 7 Tighten the two screws for connecting the attachment, placing a washer and guide angle in the respective threads of the fan housing (fig. 47, 1). Do not tighten the screws yet.

**WARNING!****HEALTH RISK caused by dust:**

**Make sure that the belt tightening plate is not located between the attachment and the fan housing (fig. 47, 2)! Otherwise, a significant amount of dust will escape from this area during sanding!**

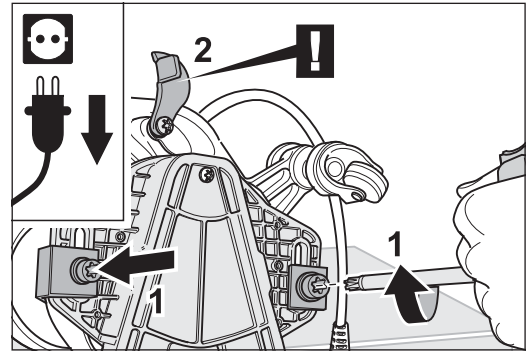

Fig. 47 Turn both screws for connecting the attachment and place a washer and a guide angle in the respective thread of the fan housing (1). **Make sure that the belt tightening plate is not located between the attachment and the fan housing (2)!**

- 8 Tighten the V-belt (→ *Section 7.2, Tightening the V-belt*).

**Checking the belt tension again after break-in time of a few days and tighten the V-belt again if necessary!**

#### 7.4 REPLACING THE COMPLETE SANDING PLATE

Use only original LÄGLER® sanding plates (part number in *Section 11, Spare parts FLIP®*)!

If it is determined while replacing the V-belt that the sanding plate pulley is worn-out, the complete sanding plate must be replaced as follows:

- 1 **Switch off the machine and pull the power plug out of the socket!**
- 2 Remove the attachment from the machine and dismantle the complete sanding plate (→ *Section 7.3.1, Removing the V-belt*).
- 3 Put the attachment with a new complete sanding plate back on the machine (→ *Section 7.3.2, Installing the V-belt*).

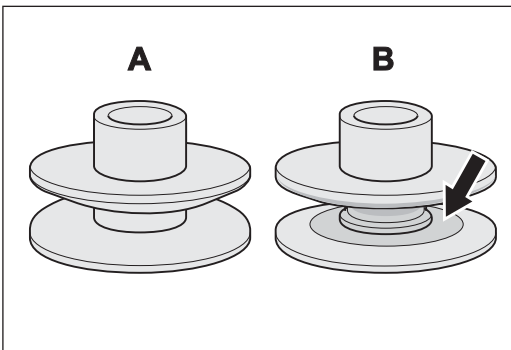

Fig. 48 A: New motor pulley,  
B: worn-out motor pulley that must be replaced.

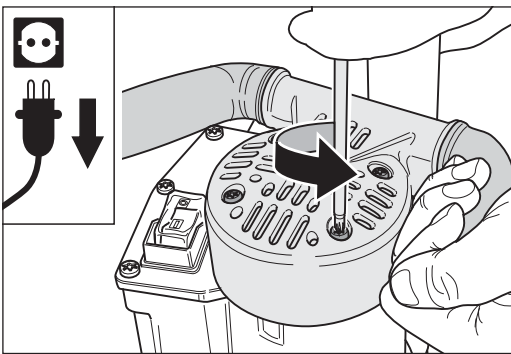

Fig. 49 Remove the four fixing screws of the handle.

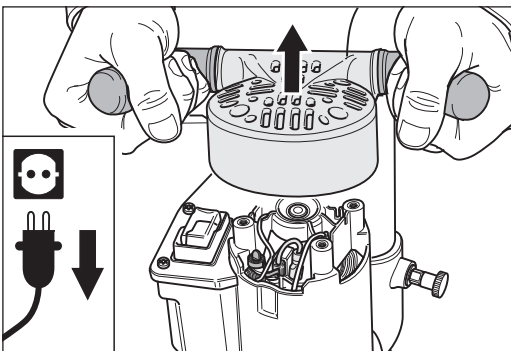

Fig. 50 Remove the handle.  
**Make sure that no parts fall into the motor!**

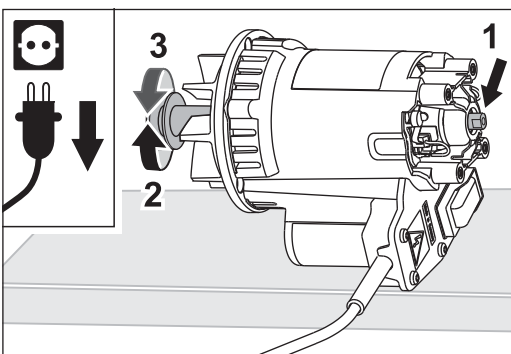

Fig. 51 Hold the end of the motor shaft with a spanner (1) and unscrew the motor pulley from the shaft (2). Screw on the new motor pulley (3).

## 7.5 REPLACING THE MOTOR PULLEY

Use only original LÄGLER® motor pulleys (part number in *Section 11, Spare parts FLIP®*)!

The motor pulley is subjected to increased wear due to the high motor speed of the FLIP®. In order to prevent excessive wearing of the V-belt, the pulley should be replaced in a timely fashion (fig. 48).

- 1 **Switch off the machine and pull the power plug out of the socket!**



### **WARNING!**

**RISK OF DEATH from electrical shock:**

**When disassembling the motor, the power plug must always be removed from the socket!**

- 2 Undo the four fixing screws of the handle (fig. 49) and remove it from the motor housing (fig. 50). **Make sure that no parts fall into the motor when doing so!**
- 3 Remove the attachment from the machine (→ *Section 7.3.1, Removing the V-belt*).
- 4 Lay the motor on its side.
- 5 Hold one end of the motor shaft tightly with an SW 10 spanner (fig. 51, 1) and use a pair of pliers to unscrew the motor pulley from the motor shaft (fig. 51, 2).
- 6 Clean the threads of the motor shaft and the contact surface of the motor pulley carefully.
- 7 **IMPORTANT:**  
Oil the inside of the motor pulley drill hole.
- 8 Turn the new motor pulley onto the motor shaft (fig. 51, 3).

## MAINTENANCE WORK AND REPLACEMENT OF WEARING PARTS

- 9 Tighten the motor pulley using the spanner and pliers.
- 10 Install the handle on the motor housing.

**WARNING!**

**RISK OF DEATH from electrical shock:**

**Do not pinch any cables while installing the handle!**

- 11 Install the attachment on the machine (→ *Section 7.3.2, Installing the V-belt*) and tighten the V-belt (→ *Section 7.2, Tightening the V-belt*).

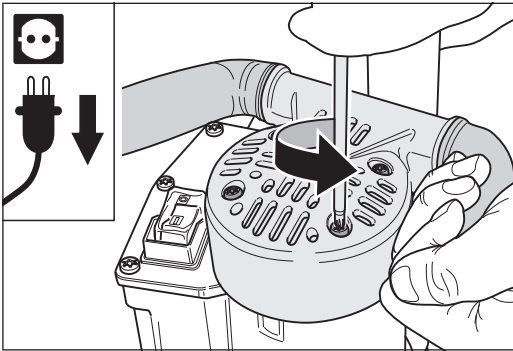

Fig. 52 Remove the four fixing screws of the handle.

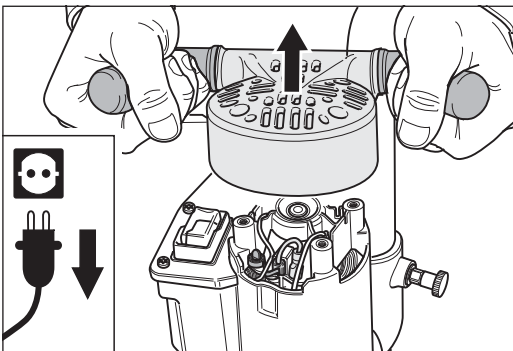

Fig. 53 Remove the handle.  
**Make sure that no parts fall into the motor!**

## 7.6 REPLACING THE CARBON BRUSHES

Use only original LÄGLER® carbon brushes (part number in *Section 11, Spare parts FLIP®*)!

In order to prevent damage to the collector from excessively worn-out carbon brushes, LÄGLER® carbon brushes with safety contacts are used. These safety contacts automatically switch off the motor when the wear limit is reached. The carbon brushes should, however, be replaced at least once a year to avoid damage to the motor!

### ATTENTION!

- The carbon brushes must be replaced at the latest upon the reaching of the wear limit and the automatic switching off of the motor! While the automatic switching off can be prevented by pressing and holding the switch, this will cause permanent damage to the switch and the collector! These parts will then have to be replaced! There are no warranty claims for damages of this nature!
- Use only original FLIP® carbon brushes with safety contacts (part number in *Section 11, Spare parts FLIP®*)!
- In order to extend the service life of the motor, a qualified electrician should remove the carbon remnants on the collector every other time the carbon brushes are replaced!

- 1 Switch off the machine and pull the power plug out of the socket!



### WARNING!

#### RISK OF DEATH from electrical shock:

- When disassembling the motor, the power plug must always be removed from the socket!
- Make sure that no parts fall into the motor!

- 2 Undo the four fixing screws of the handle (fig. 52) and remove it from the motor housing (fig. 53). **Make sure that no parts fall into the motor when doing so!**

- 3 Pull off the connector of **one** of the carbon brushes from the carbon holder (fig. 54, 1).
- 4 Turn the brass pressure clamp of the carbon holder to the side using the universal spanner (fig. 54, 2) and remove the worn-out carbon brush (fig. 54, 3).
- 5 Insert the new carbon brush (fig. 55, 1) and turn back the brass pressure clamp of the carbon holder (fig. 55, 2).
- 6 Attach the carbon brush connector to the contact in the carbon holder provided (fig. 55, 3). Install the carbon brush cable like the other old carbon brushes that are still installed. This will prevent a later pinching of the cable.
- 7 Replace the second carbon brush in the same manner.
- 8 Install the handle on the motor housing.

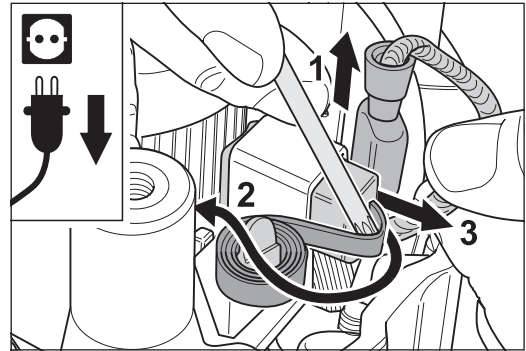

Fig. 54 Pull off the connector (1), turn the brass pressure clamp to the side (2) and remove the carbon brush (3).

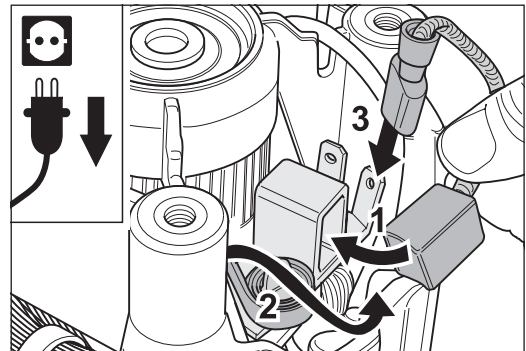

Fig. 55 Insert the new carbon brush (1), turn the brass pressure clamp back (2) and attach the connector (3).



#### **WARNING!**

#### **RISK OF DEATH from electrical shock:**

**Do not pinch any cables while installing the handle!**

## 7.7 CHECKING THE DUST SUCTION SYSTEM

In order to ensure optimal dust suction for your own safety and the safety of others, the following points must be taken into consideration.

- Use only original LÄGLER® dust bags for the FLIP® (part number in *Section 11, Spare parts FLIP®*)!
- Do not use any dust bags which have been damaged, washed, patched or repair in any other way!
- Ensure that the guide rollers are correctly positioned!
- Check the dust suction system for any clogged-up material or deposits!
- Make sure that the dust bag and locating flange are connected properly!

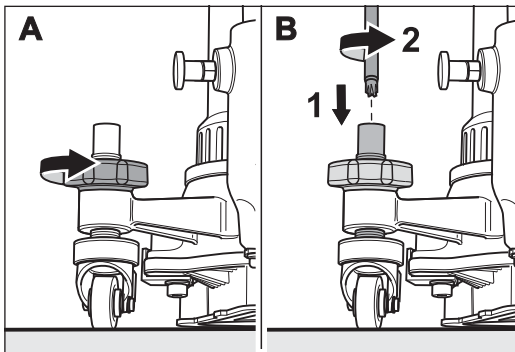

Fig. 56 Undo the locknut on the guide roller.

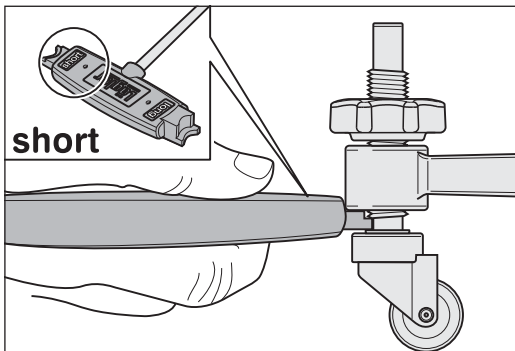

Fig. 57 Standard setting for the **short attachment** and the **corner attachment**.

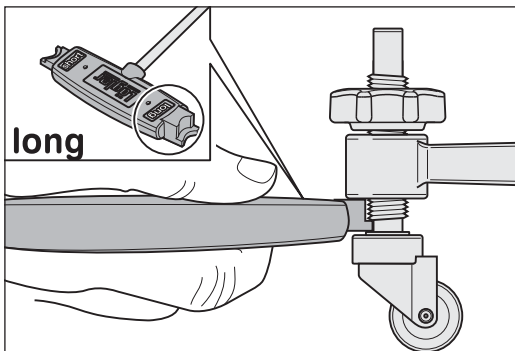

Fig. 58 Standard setting for the **long attachment**.

## 7.8 ADJUSTING THE GUIDE ROLLERS

The position of the guide rollers effects the sanding results and the aggressiveness of the machine.

### 7.8.1 STANDARD SETTING

The two alignment marks on the universal spanner can be used to set a position for the guide rollers, which is suitable for both rough and fine sanding work for the respective attachment.

This is achieved by holding the corresponding alignment mark of the universal spanner, depending on the attachment used, between the guide roller and the fan housing and this spacing is then set (see below for the procedure).

This setting allows a horizontal and even sanding which does not overload the machine and leads to an even and attractive sanded finish.

The standing setting of the guide rollers is conducted as follows:

- 1 **Switch off the machine and pull the power plug out of the socket!**
- 2 Loosen the locknut of the guide roller to be adjusted (fig. 56, **A**).  
If the locknut is screwed on too tightly, you can turn the vertical guide roller axis counterclockwise with the universal spanner to loosen the locknut (fig. 56, **B**).
- 3 Hold the appropriate universal spanner alignment mark for the attachment used between the guide roller and the fan housing. The lettering on the spanner must be legible from above (fig. 57 and fig. 58).

Alignment marks for the - short attachment: **short**  
 - long attachment: **long**  
 - Corner attachment: **short**

- 4 Now turn the guide roller in the direction required until the alignment mark on the fan housing and the guide roller match up (fig. 57 and fig. 58).
- 5 Retighten the locknut.
- 6 Adjust the second guide roller.

---

 MAINTENANCE WORK AND REPLACEMENT OF WEARING PARTS
 

---

- 7 Conduct a trial sanding operation and check the sanding results.
- 8 If the machine sands **centrally** (fig. 59), the guide rollers are properly adjusted.
- 9 If the machine sands too much to the right (fig. 60) or to the left (fig. 62), the guide rollers are **not adjusted to the same height** (fig. 61 and fig. 63)!
- 10 Adjust both guide rollers to the **same height** (→ *steps 1 to 6*) and repeat the trial sanding operation.

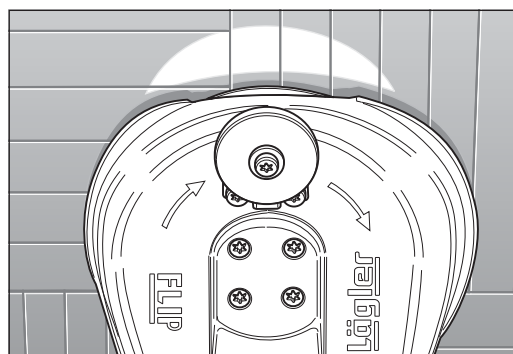

Fig. 59 Proper adjustment of the guide rollers:  
The machine sands **centrally**.

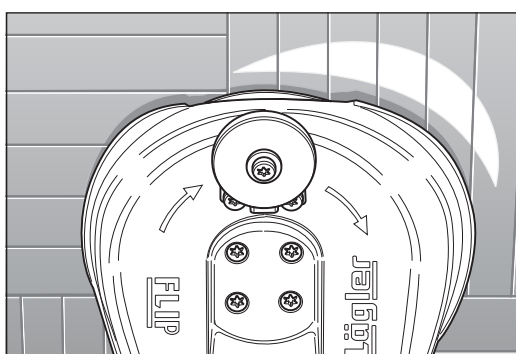

Fig. 60 Improper adjustment of the guide rollers:  
The sanding zone of the machine is too much to the **right**.

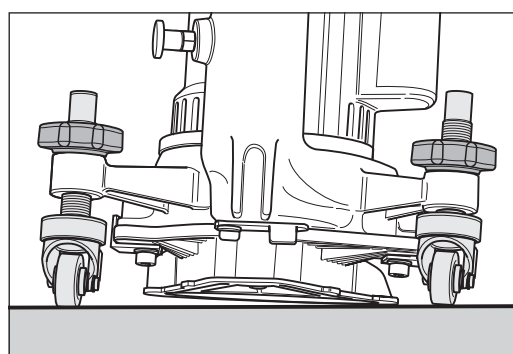

Fig. 61 The sanding zone of the machine is too much to the **right**:  
The **left** guide roller is lifting the machine too much.

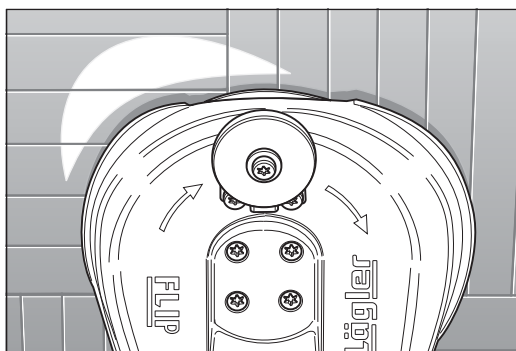

Fig. 62 Improper adjustment of the guide rollers:  
The sanding zone of the machine is too much to the **left**.

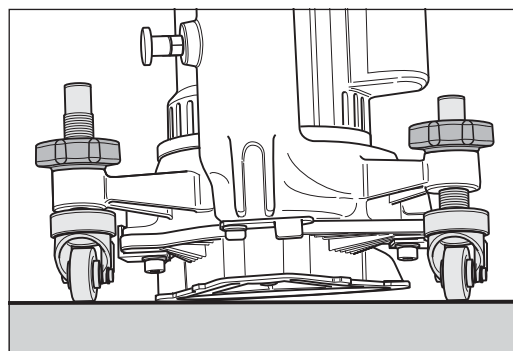

Fig. 63 The sanding zone of the machine is too much to the **left**:  
The **right** guide roller is lifting the machine too much.



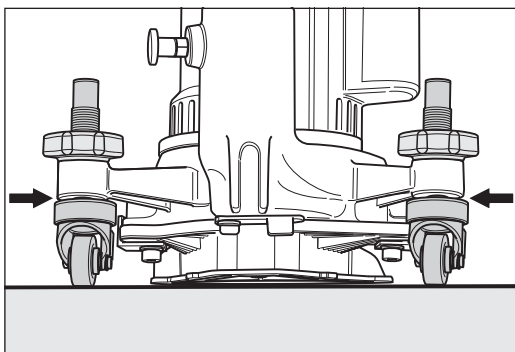

Fig. 64 Flat adjustment angle for fine sanding work.

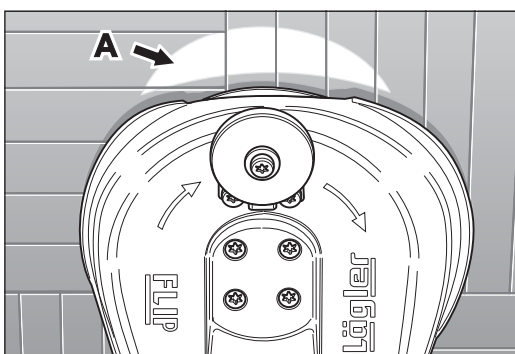

Fig. 65 Large sanding surface A and therefore lower aggressivity of the abrasive.

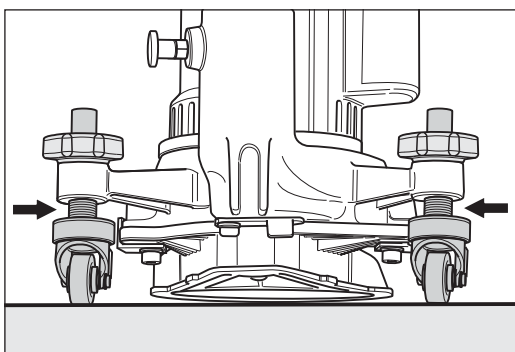

Fig. 66 Steeper adjustment angle for rough sanding work.

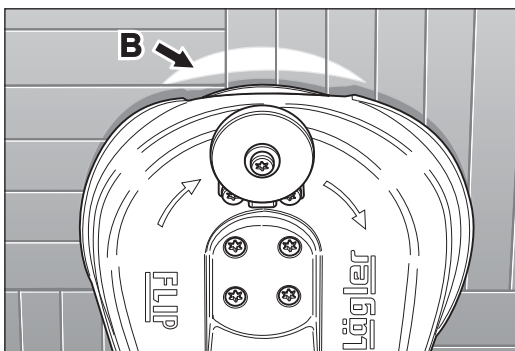

Fig. 67 Small sanding surface B and therefore major aggressivity of the abrasive.

## 7.8.2 SETTING FOR SPECIAL CASES

In order to achieve a major abrasion at coarse sanding works **no additional pressure** must be applied to the attachment! The sanding pressure and consequently the aggressivity of the abrasive with the FLIP® are adjusted by the guide rollers!

With a flat machine adjustment for fine sanding works (fig. 64) a larger part of the sanding plate's surface is touching the floor (fig. 65, A) than this would be the case with a steeper machine adjustment for coarse sanding works (fig. 66 and fig. 67, B).

**The steeper the machine adjustment the more aggressive the abrasive!**

The standard setting can easily be restored using the universal spanner (→ Section 7.8.1, Standard setting).

If you would like a steeper or flatter setting than the standard setting, proceed as follows:

- 1 **Switch off the machine and pull the power plug out of the socket!**
- 2 Loosen the locknut of the guide roller to be adjusted (fig. 56, A).  
If the locknut is screwed on too tightly, you can turn the vertical guide roller axis counterclockwise with the universal spanner to loosen the locknut (fig. 56, B).
- 3 Now turn the guide roller one or two rotations in the desired direction.
- 4 Retighten the locknut.
- 5 Adjust the second guide roller.
- 6 Conduct a trial sanding operation and check the sanding results (→ Section 7.8.1, Standing setting, steps 8 to 10).



## 7.9 REPLACING THE WHEELS AND THE GUIDE ROLLERS

### ATTENTION!

- **Blocked wheels or guide rollers restrict the mobility of the machine and leave marks on the floor! These parts must be replaced!**
- **Always replace both wheels or guide rollers!**

### 7.9.1 REPLACING THE WHEELS

Use only original LÄGLER® wheels (part number in *Section 11, Spare parts FLIP®*)!

The wheels must be replaced when the contact surfaces are worn-out or damaged or the wheels can only be turned by applying additional force.

- 1 Switch off the machine and pull the power plug out of the socket!**
- 2 Remove the screw with the two washers and the nut from the wheel fork (fig. 68, 1).
- 3 Remove the wheel from the wheel fork (fig. 68, 2).
- 4 Install the new wheel in the reverse order.

### 7.9.2 REPLACING THE GUIDE ROLLERS

Use only original LÄGLER® guide rollers (part number in *Section 11, Spare parts FLIP®*)!

The guide rollers must be replaced when the wheel forks only rotate around the vertical guide roller axes with increased force!

- 1 Switch off the machine and pull the power plug out of the socket!**
- 2 Remove the locknut of the guide roller (fig. 56).

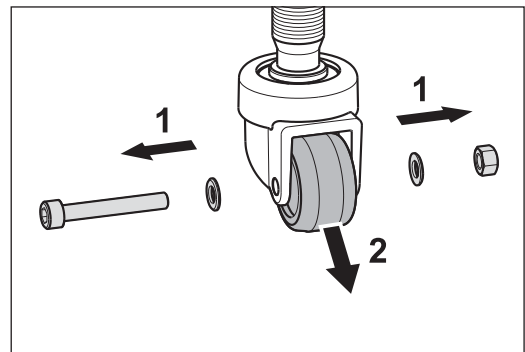

Fig. 68 Remove the screw, the two washers and the nut (1) and remove the wheel from the wheel fork (2).

- 3 Rotate the vertical guide roller axis completely out of the fan housing.

**NOTE:**

A light film of oil on the thread of the new guide roller makes the adjustment work easier.

- 4 Rotate the vertical axis of the new guide roller into the fan housing.
- 5 Set the position of the guide roller using the universal spanner (→ *Section 7.8, Adjusting the guide rollers*). Mount the locknut and tighten it.
- 6 Check the setting of the guide rollers (→ *Section 7.8, Adjusting the guide rollers*).

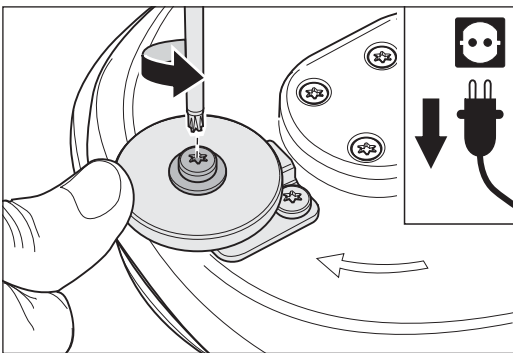

Fig. 69 Undo the screw in the middle of the wall-protecting roller.

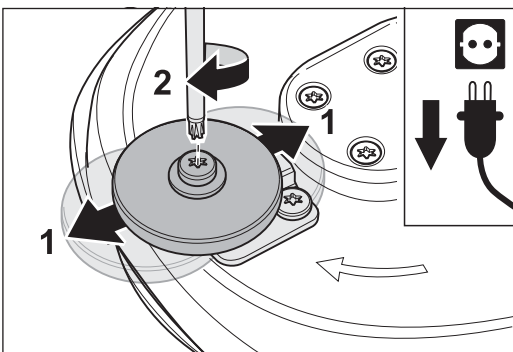

Fig. 70 Push the wall-protecting roller (1) and tighten the screw (2).

## 7.10 ADJUSTING THE WALL-PROTECTING ROLLER

Adjusting the wall-protecting roller can avoid damaging or sanding various wall shapes or skirting boards.

- 1 **Switch off the machine and pull the power plug out of the socket!**
- 2 Use the universal spanner to undo the screw in the middle of the wall-protecting roller (fig. 69).
- 3 Push the wall-protecting roller into the position you require (fig. 70, 1) and retighten the screw (fig. 70, 2).
- 4 Check the position by placing the switched off FLIP® against the wall so that the wall-protecting roller rests against the wall or skirting board.
- 5 The sanding plate must not be touching the wall. Otherwise, push the wall-protecting roller in the desired direction.

If you deliberately want to sand right up to the wall, you can push the wall-protecting roller completely out of the working area.

If you want to sand under low radiators or cupboards, you can completely remove the wall-protecting roller:

- 1 **Switch off the machine and pull the power plug out of the socket!**
- 2 Undo the screw in the middle of the wall-protecting roller with the universal spanner (fig. 71, 1) and push the wall-protecting roller into the front position (fig. 71, 2).
- 3 Undo the two screws attaching the holder of the wall-protecting roller to the attachment (fig. 72, 1) and remove the complete wall-protecting roller (fig. 72, 2).

### 7.11 REPLACING THE WALL-PROTECTING ROLLER

Use only original LÄGLER® wall-protecting rollers (part number in *Section 11, Spare parts FLIP®!*)

- 1 **Switch off the machine and pull the power plug out of the socket!**
- 2 Use the universal spanner to undo the screw in the middle of the wall-protecting roller (fig. 71, 1).
- 3 Remove the old wall-protecting roller.
- 4 Insert the bush in the new wall-protecting roller and place it on the holder of the wall-protecting roller with a washer on each side. **Ensure that the middle of the roller is located over the nut in the holder (fig. 73)!**
- 5 Turn the screw through the drill holes in the washer and the bush into the nut.
- 6 Adjust the position of the wall-protecting roller according to your needs (→ *Section 7.10, Adjusting the wall-protecting roller*).

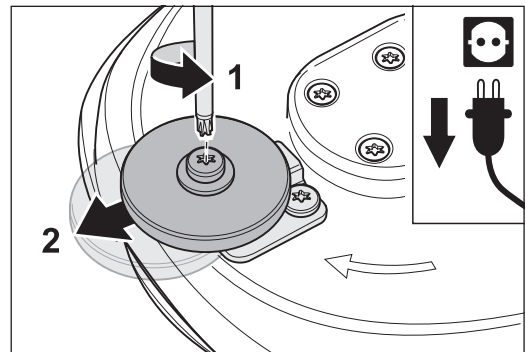

Fig. 71 Undo the screw (1) and push the wall-protecting roller (2).

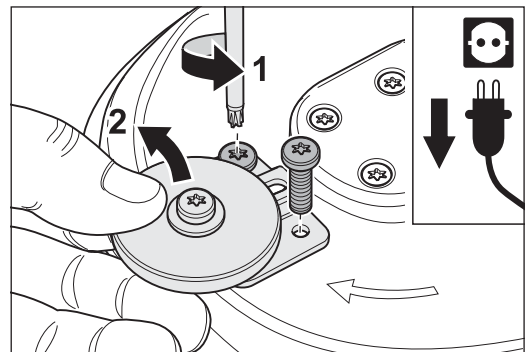

Fig. 72 Undo the fixing screws (1) and remove the complete wall-protecting roller (2).

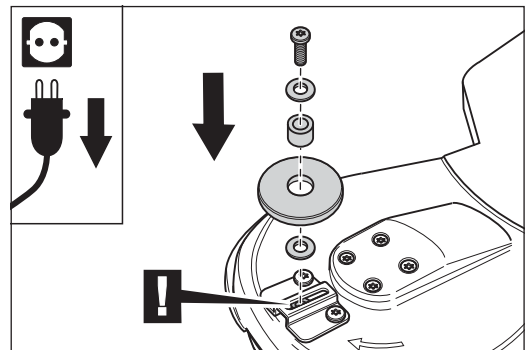

Fig. 73 Assembly of the wall-protecting roller. **Pay attention to the nut in the holder!**

# Regular inspection and maintenance work in accordance with accident prevention regulations



## **WARNING!**

**Tests and testing intervals must comply with and be performed in accordance with the applicable regulations and legal requirements in your country!**

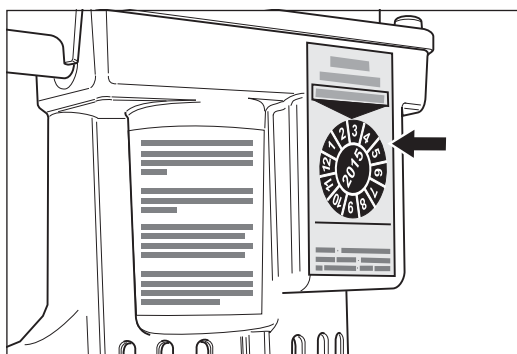

Fig. 74 The inspection label on the motor housing confirms the electrical and mechanical safety of the machine.

The electrical operating equipment and machine parts must be inspected at least once a year by a qualified electrician with respect to electrical and mechanical safety, then be repaired as required. Afterwards, the operational safety must be confirmed by the attachment of an inspection label on the machine (fig. 74).

The elements required for the dust suction system must be checked at least once a year by a qualified expert and repaired as required. The functional efficiency must also be confirmed.

**Ensure that only original LÄGLER® spare parts are used for maintenance work!** You should only allow the customer service work to be conducted by LÄGLER® or an authorized LÄGLER® service centre!

The service passport in these operating instructions (*Section 12*) documents when and where your machine was serviced.

**Enter the serial number and the year of manufacture of your machine (please see the type plate) on the back cover of these operating instructions! If you do not do this, your service passport is invalid!**

Make sure that the maintenance tasks in the service passport are confirmed by filling in a corresponding field with the date, stamp and signature.



## **WARNING!**

**In order to ensure the safety of the machines and equipment (= working equipment), the German Ordinance on Industrial Safety and Health (BetrSichV) must be complied with in Germany!**

## REGULATIONS VALID IN GERMANY

The German Ordinance on Industrial Safety and Health (BetrSichV) requires every employer to define the testing intervals on the work equipment they provide according to a risk analysis and to document all of this.

**EXCERPT FROM THE GERMAN ACCIDENT PREVENTION REGULATIONS "DGUV VORSCHRIFT 3" (November 2013)**

**§ 5 Inspections**

- (1) The employer must ensure that the proper condition of the electrical systems and equipment is inspected
1. before using the equipment for the first time and after an alteration or repair before being used again by an electrician or under the supervision of an electrician and
  2. at regular intervals.

The intervals are to be calculated in such a manner that defects which must be handled are detected in a timely manner.

- (2) The electrical engineering regulations relevant to the inspection are to be followed.
- (3) Upon request by the professional association, an inspection log with specific entries is to be maintained.
- (4) The inspection before the first commissioning as per paragraph 1 is not required if the employer receives confirmation from the manufacturer or installer that the electrical systems and equipment have been correspondingly procured in accordance with these accident prevention guidelines.

**Table 1B: Recurring inspections of portable electrical equipment:**

**Systems/equipment** (which are to be inspected)

- portable electrical equipment (insofar as is used)
- extension and device connection cables with plugs
- connection cables with plugs
- movable cables with plugs and fixed connections

**Inspection interval**

Every 6 months as a reference value, **3 months on construction sites\***).

If an error rate of less than 2% is reached during the inspection, the inspection interval can be extended to a maximum of 1 year (valid for machines on construction sites, in production facilities and workshops).

\*) See the BG information "Selection and Operation of Electrical Systems and Equipment on Construction Sites" (DGUV Information 203-006) for more details.

**Type of inspection**

The proper condition of the machines and equipment must be inspected.

**Inspector**

Electricians or persons trained in electrical engineering when using suitable measurement and inspection devices.

**NOTE:**

- All LÄGLER® machines and electrical equipment are subjected to an electrical inspection as well as a thorough visual and functional test before they leave the factory.
- A recurring inspection of the machines and electrical equipment must be conducted in Germany at certain intervals.
- LÄGLER® recommends using the guidelines of the German accident prevention regulations "DGUV Vorschrift 3" for inspections and inspection intervals.
- You can, of course, arrange for repairs and recurring inspections of LÄGLER® machines to be conducted by the LÄGLER® service department.

# Causes of faults



## **WARNING!**

### **RISK OF DEATH from electrical shock:**

**Work on the electrical equipment is to be conducted exclusively by a qualified electrician (circuit diagram in *section 10*)! The machine must be switched off and the power plug removed from the socket during this work!**

### **RISK OF INJURY due to unsuitable parts:**

**Make sure that only original LÄGLER® spare parts and original LÄGLER® accessories are used!**

This section shows you how to remedy possible malfunctions. If none of the measures listed here are successful, please contact our service department, your retailer or your importer.

## 9.1 THE MACHINE DOES NOT RUN OR HAS SWITCHED OFF AUTOMATICALLY

- The machine is not connected to the electrical network. Check the following items:
  - Is the motor cable connected to the extension cable?
  - Is the extension cable inserted into the power socket?
- The power socket is not properly connected. This error must be corrected by an expert.
- The electrical safety device of the electrical network interrupted the electrical circuit, e.g. because
  - too many electricity consumers are connected to the same electrical circuit,
  - improper electrical installation.
 The causes for the error must be repaired by an expert.
- The electrical network is not providing sufficient voltage (undervoltage). Use a transformer if necessary (e.g. LÄGLER® part number 708.00.00.100 for 230 V).
- The temperature switch in the motor has switched off the machine because
  - the power cables have a total length of more than 20 m (790"),
  - the power cables have wire cross-sections which are smaller than 1.5 mm<sup>2</sup> (0.0023 sq.in.),
  - or too much pressure was applied to the attachment while sanding.
 The motor must cool off and the causes for the problems named above must be remedied.
- An electrical component of the machine (e.g. cable, switch) is defective and must be inspected by a qualified electrician and replaced if necessary.
- The wear limit of the carbon brushes has been reached. The carbon brushes must be replaced.
  - ➔ *Section 7.6, Replacing the carbon brushes***Use only original FLIP® carbon brushes with safety contacts (part number in *section 11, Spare parts FLIP®*)!**

## 9.2 THE MACHINE ATTEMPTS TO START UP BUT IS NOT ABLE TO DO SO

- At low temperatures: The machine is too cold and must be heated up to room temperature in a warm room.
- Cables which are too long or too thin are used for the electrical connection:
  - The power cables have a total length of more than 20 m (790").
  - The power cables have wire cross-sections which are smaller than 1.5 mm<sup>2</sup> (0.0023 sq.in.).
 This causes of faults lead to a loss of power and are not allowed for safety reasons!
- The electrical network is not providing sufficient voltage (undervoltage). Use a transformer if necessary (e.g. LÄGLER® part number 708.00.00.100 for 230 V).
- The V-belt is too tight and must be loosened.  
 ➔ *Section 7.2, Tightening the V-belt*

## 9.3 THE MACHINE RUNS BUT HAS NO OR VERY LITTLE SANDING POWER CAPACITY

- The sanding medium is incorrect or dull and must be replaced.  
 ➔ *Section 5.2, Replacing the sanding medium*
- At low temperatures: The machine is too cold and must be heated up to room temperature in a warm room.
- Cables which are too long or too thin are used for the electrical connection:
  - The power cables have a total length of more than 20 m (790").
  - The power cables have wire cross-sections which are smaller than 1.5 mm<sup>2</sup> (0.0023 sq.in.).
 This causes of faults lead to a loss of power and are not allowed for safety reasons!
- The electrical network is not providing sufficient voltage (undervoltage). Use a transformer if necessary (e.g. LÄGLER® part number 708.00.00.100 for 230 V).
- The V-belt is not tight enough and must be tightened a bit.  
 ➔ *Section 7.2, Tightening the V-belt*
- The machine setting angle is too flat. The guide rollers must be properly adjusted.  
 ➔ *Section 7.8, Adjusting the guide rollers*

#### 9.4 THE MACHINE VIBRATES INTENSELY AND RUNS NOISILY

---

- The sanding medium does not have the proper tension. The tension must be corrected.  
➔ *Section 5.2, Replacing the sanding medium*
- The sanding medium is damaged or incorrect and must be replaced.  
➔ *Section 5.2, Replacing the sanding medium*
- The V-belt is dirty, damaged or worn-out and must be replaced.  
➔ *Section 7.3, Replacing the V-belt*
- A pulley is dirty, damaged or worn-out and must be cleaned or replaced.  
➔ *Section 7.4, Replacing the complete sanding plate*  
➔ *Section 7.5, Replacing the motor pulley*
- There are clogged materials and deposits in the machine that must be removed.  
➔ *Section 7.1, Cleaning and care*

#### 9.5 THE MACHINE RUNS BUT CREATES A GREAT DEAL OF DUST

---

- The dust bag is more than one third full and must be emptied.  
➔ *Section 5.3, Emptying the dust bag*
- The dust bag is not correctly attached or is damaged and must be replaced.  
➔ *Section 4.1, Preparing the machine*
- When mounting the attachment, the belt tightening plate was pinched between the attachment and the fan housing. The attachment must be properly installed.  
➔ *Section 7.3.2, Installing the V-belt*
- There are clogged materials and deposits in the machine that must be removed.  
➔ *Section 7.1, Cleaning and care*
- More than one sanding disc is mounted. Only install one sanding disc.  
➔ *Section 5.2, Replacing the sanding medium*
- The machine setting angle is too steep. The guide rollers must be properly adjusted.  
➔ *Section 7.8, Adjusting the guide rollers*



- The FLIP® with **short or long attachment** has **not** been handled with rotary **clockwise** movements during the sanding process!  
The FLIP® with **corner attachment** has **not** been handled with **counterclockwise** movements during the sanding process!  
➔ *Section 5.1, General application tips*
- Too much pressure is placed on the sanding disc during the sanding process. Do not press too hard on the attachment during the sanding process.

## 9.6 SANDING PROBLEMS (WAVES, STRIPS, GROOVES)

- The floor or stairs were not vacuumed before sanding. The floor or stairs must be vacuumed thoroughly always directly before each sanding step.
- The sanding disc was not lifted from the floor while the machine was switched on or off. Always tilt the machine backwards slightly before switching the machine on or off so that the sanding disc is lifted off the floor.  
➔ *Section 4.3, Switching on the machine*  
➔ *Section 4.4, Switching off the machine*
- The machine is being moved too slowly and must be sped up.
- The FLIP® with **short or long attachment** has **not** been handled with rotary **clockwise** movements during the sanding process!  
The FLIP® with **corner attachment** has **not** been handled with **counterclockwise** movements during the sanding process!  
➔ *Section 5.1, General application tips*
- The sanding medium does not have the proper tension. The tension must be corrected.  
➔ *Section 5.2, Replacing the sanding medium*
- The sanding medium is damaged or incorrect and must be replaced.  
➔ *Section 5.2, Replacing the sanding medium*
- The machine setting angle is not correct. The guide rollers must be properly adjusted.  
➔ *Section 7.8, Adjusting the guide rollers*
- The wheels are dirty or damaged and must be cleaned or replaced.  
➔ *Section 7.9, Replacing the wheels and the guide rollers*

---

## CAUSES OF FAULTS

---

- The V-belt is dirty, damaged or worn-out and must be replaced.  
➔ *Section 7.3, Replacing the V-belt*
- A pulley is dirty or worn-out and must be cleaned or replaced  
➔ *Section 7.4, Replacing the complete sanding plate*  
➔ *Section 7.5, Replacing the motor pulley*
- Too much pressure is placed on the sanding disc during the sanding process. Do not press too hard on the attachment during the sanding process.

CIRCUIT DIAGRAM

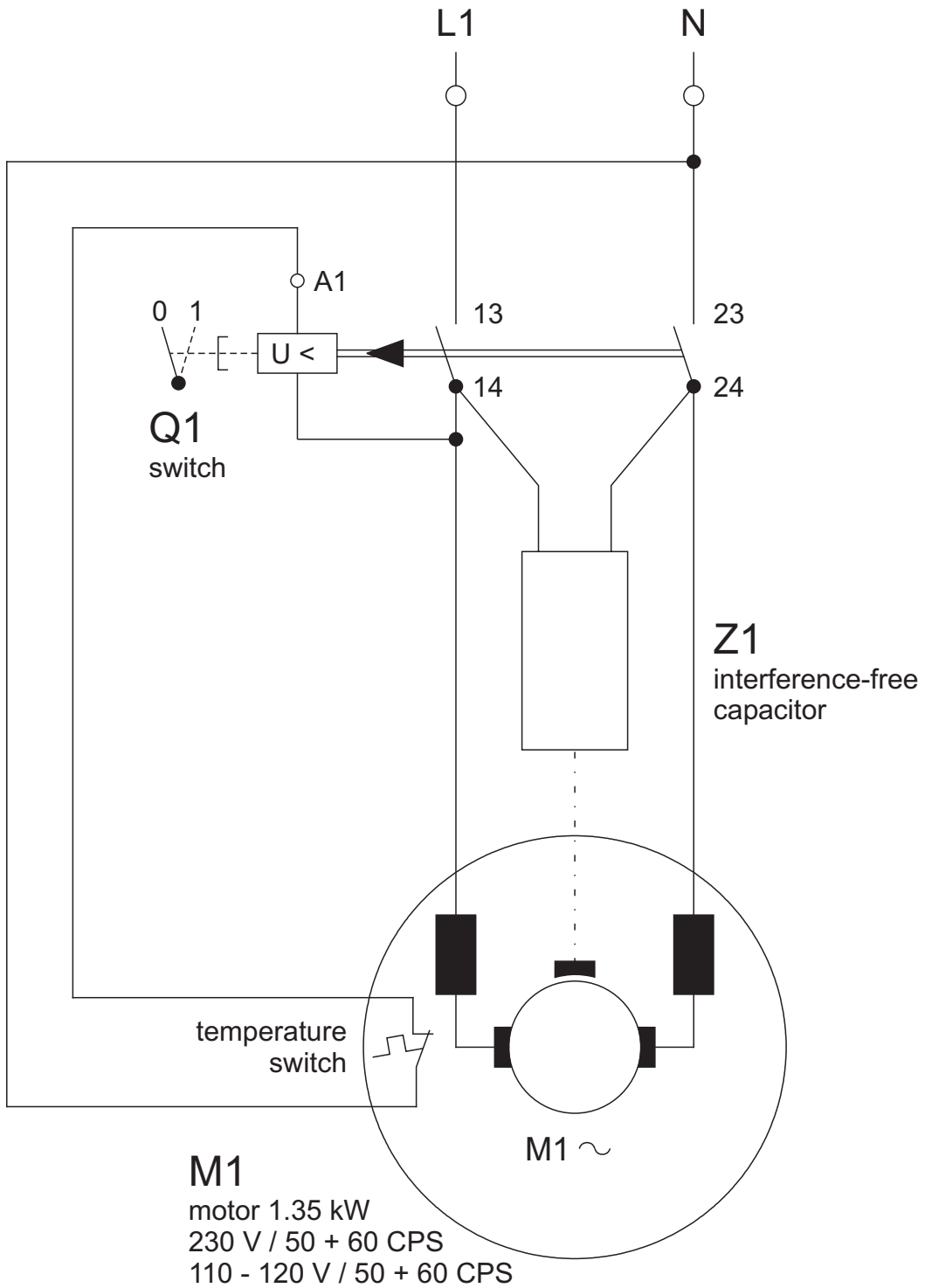

01.01.2010

FLIP®: universal motor

1.35 kW / 230 V / 50 + 60 CPS  
 1.35 kW / 110 - 120 V / 50 + 60 CPS

EUGEN LÄGLER GMBH  
 Kappelrain 2  
 D-74363 Güglingen-Frauenzimmern

Phone: 0049 - 7135 - 98 90 - 0  
 Fax: 0049 - 7135 - 98 90 - 98

e-mail: info@laegler.com  
 Internet: http://www.laegler.com

SPARE PARTS FLIP®

ATTENTION: Please specify in inquiries and spare part orders always the serial numbers of your machines (→ Section 3.1)!

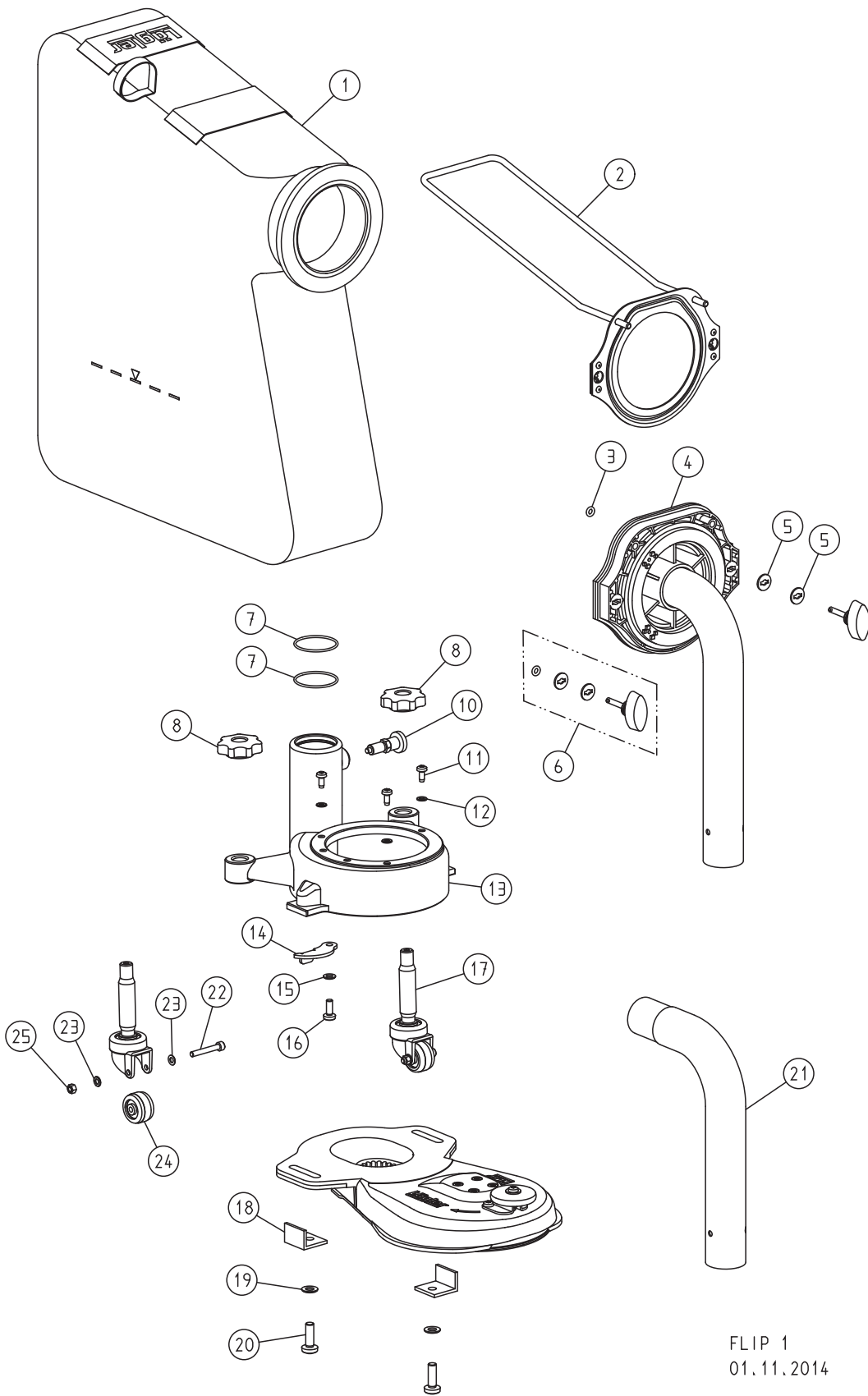

FLIP 1  
01.11.2014

## SPARE PARTS FLIP®

Item	Part number	Description
	320.00.80.100	Dust bag FLIP®, complete
1	320.00.86.105	Dust bag FLIP®
2	320.00.82.100	Fixing plate with bracket
3	000.11.05.901	O-ring
4	320.14.00.100	Pipe socket, complete
5	000.10.10.055	Washer
6	000.25.11.433	Locking pin
7	000.11.40.901	O-ring
8	320.05.11.205	Star grip (locknut)
10	000.20.15.005	Stop bolt
11	7500.1005.012	Screw
12	0125.1005.000	Washer
13	320.08.10.100	Fan housing, complete
14	320.08.03.100	Belt tightener plate
15	0125.1006.000	Washer
16	7985.1006.816	Screw
17	320.05.00.200	Guide roller, complete
18	320.01.09.100	Guide angle
19	0125.1008.000	Washer
20	7985.1008.825	Screw
21	320.14.92.100	Pipe socket for vacuum cleaner connection, 38 + 40 mm outside diameter
22	0912.1005.035	Screw
23	0125.1005.000	Washer
24	320.05.09.305	Wheel
25	0980.1005.000	Nut

ATTENTION: Please specify in inquiries and spare part orders always the serial numbers of your machines (→ Section 3.1)!

SPARE PARTS FLIP®

ATTENTION: Please specify in inquiries and spare part orders always the serial numbers of your machines (→ Section 3.1)!

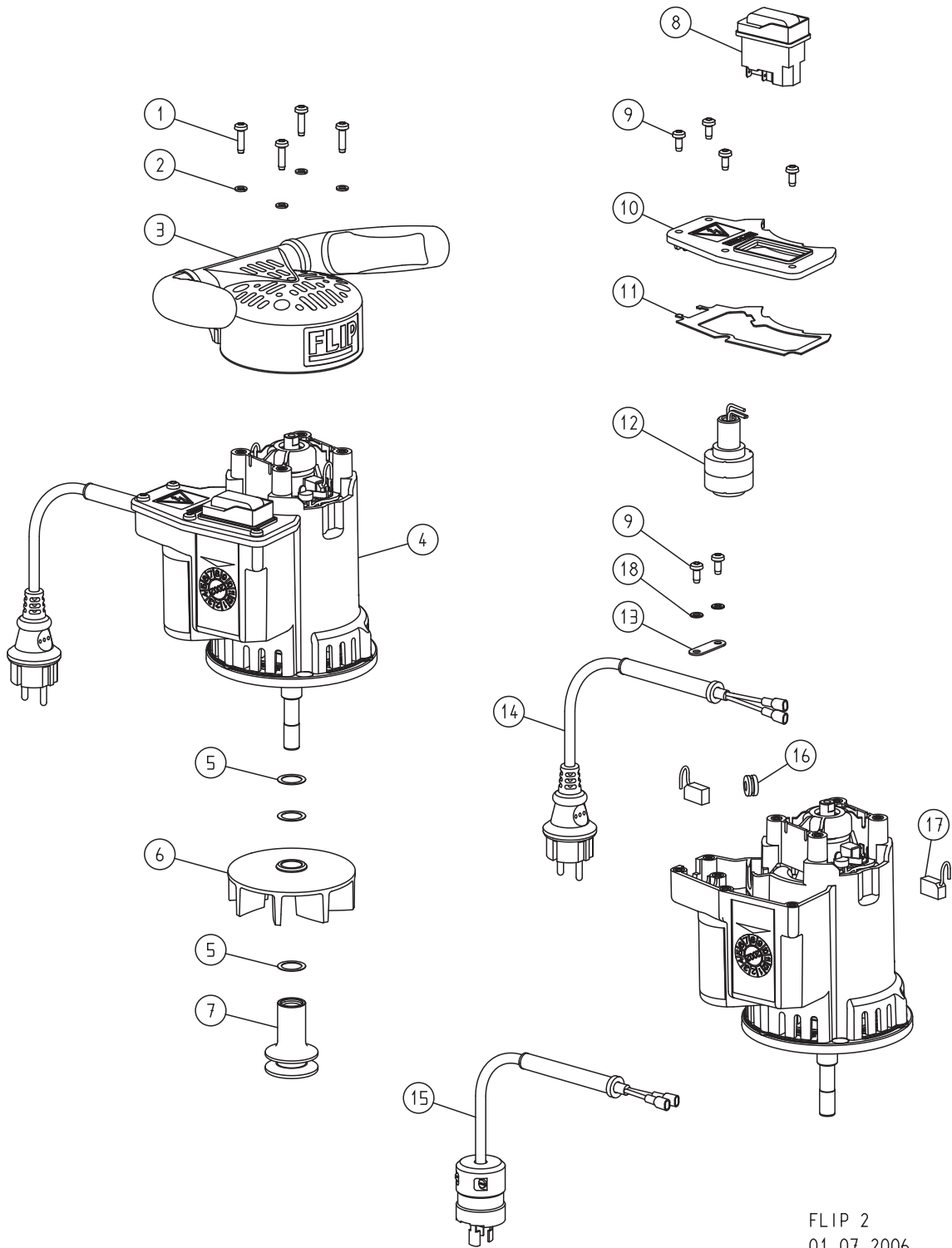

FLIP 2  
01.07.2006

## SPARE PARTS FLIP®

Item	Part number	Description
1	7500.1005.020	Screw
2	0127.1005.000	Spring washer
3	320.20.10.105	Handle FLIP®
4	320.65.00.100	Universal motor, 230 V / 50 + 60 CPS
	322.65.00.100	Universal motor, 110 V / 50 + 60 CPS, USA
5	0988.0016.005	Washer
6	320.10.10.200	Fan wheel
7	320.65.06.100	Motor pulley
8	000.65.60.256	Switch, 230 V / 50 + 60 CPS
	000.65.60.156	Switch, 110 + 120 V / 60 + 50 CPS
	000.65.62.160	PVC cap with switch frame
9	7500.1005.012	Screw
10	320.65.47.100	Cover with seal
11	320.65.48.105	Cover seal
12	320.65.30.100	Interference-free capacitor, complete
13	320.65.59.100	Latch fastener
14	000.65.42.151	Motor cable 2 x 1.5 mm <sup>2</sup>
15	000.65.42.153	Motor cable 2 x 1.5 mm <sup>2</sup> , USA
16	000.63.12.071	Rubber tube
17	000.65.84.012	Carbon brush FLIP®
18	0125.1005.000	Washer

ATTENTION: Please specify in inquiries and spare part orders always the serial numbers of your machines (→ Section 3.1)!

SPARE PARTS FLIP®

ATTENTION: Please specify in inquiries and spare part orders always the serial numbers of your machines (→ Section 3.1)!

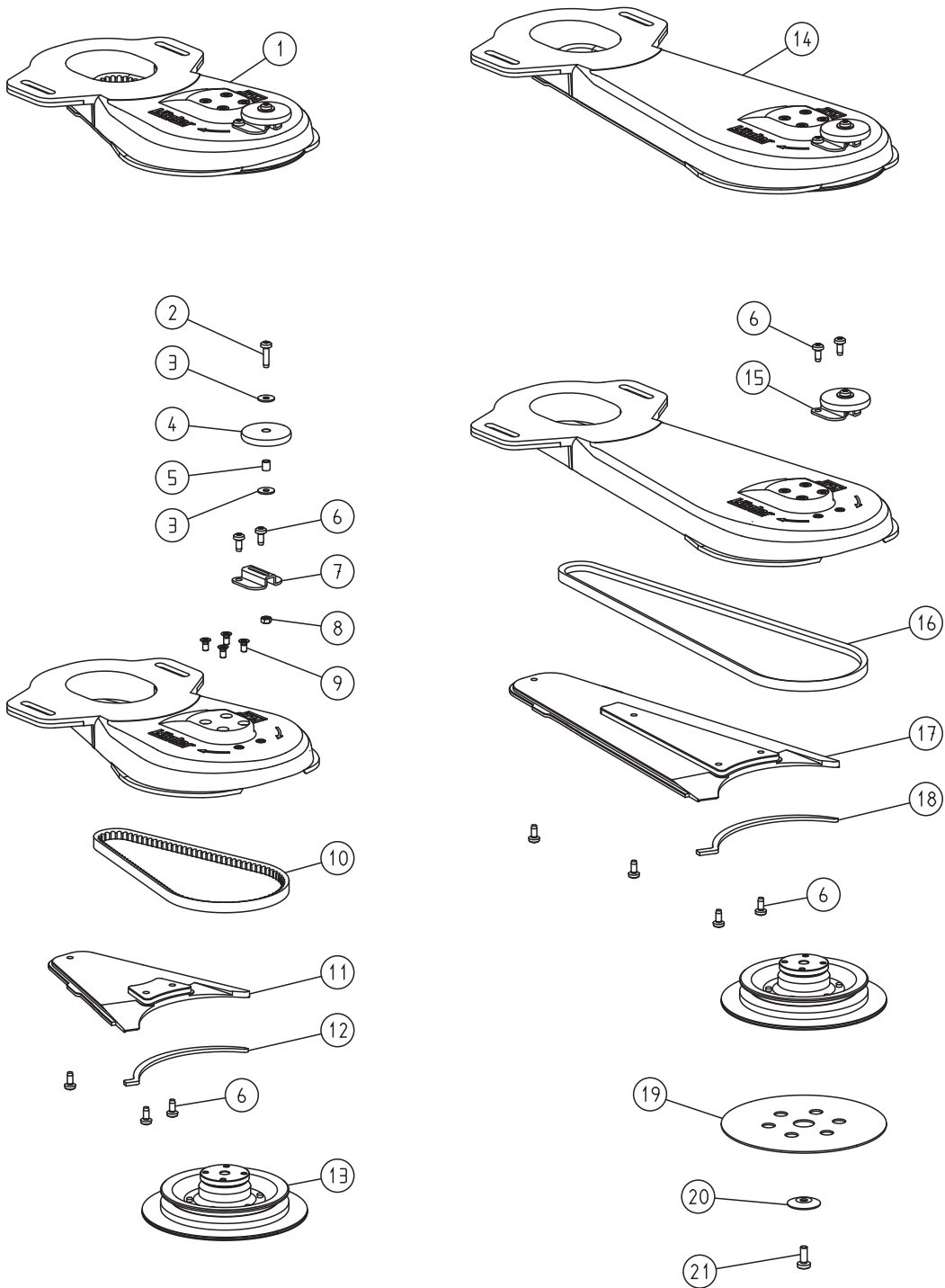

FLIP 3  
01.05.2012



Item	Part number	Description
1	320.01.00.100	Short attachment FLIP®, complete
2	7500.1005.020	Screw
3	9021.1005.000	Washer
4	320.60.02.100	Wall-protecting roller
5	000.43.15.052	Bush
6	7500.1005.012	Screw
7	320.60.01.100	Holder for wall-protecting roller
8	0934.1005.000	Nut
9	0965.1005.810	Screw
10	000.70.10.055	V-belt
11	320.01.03.100	Attachment cover short, complete
12	320.01.51.105	Seal (attachment cover short)
13	320.01.91.100	Sanding plate, complete
14	330.01.00.100	Long attachment FLIP®, complete
15	320.60.00.100	Wall-protecting roller with bracket
16	000.70.10.087	V-belt
17	330.01.03.100	Attachment cover long, complete
18	330.01.51.105	Seal (attachment cover long)
19	350.03.35.205	Velcro disc 150 mm
20	320.02.05.100	Paper tensioning disc
21	7985.1006.816	Screw

ATTENTION: Please specify in inquiries and spare part orders always the serial numbers of your machines (→ Section 3.1)!

SPARE PARTS FLIP®

ATTENTION: Please specify in inquiries and spare part orders always the serial numbers of your machines (→ Section 3.1)!

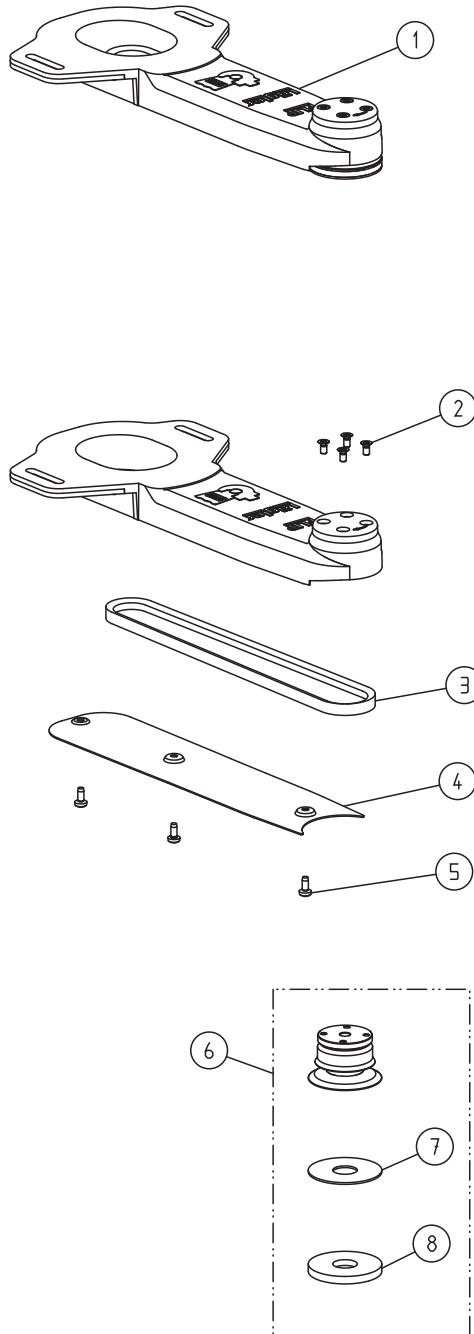

FLIP 4  
01.12.2002

## SPARE PARTS FLIP®

Item	Part number	Description
1	335.01.00.100	Corner attachment FLIP®, complete
2	0965.1005.810	Screw
3	000.70.10.067	V-belt
4	335.01.02.100	Cover, corner attachment
5	7500.1005.012	Screw
6	335.01.91.100	Sanding plate for corner attachment, complete
7	335.02.12.105	Velcro coating, self adhesive
8	335.02.13.105	Velcro ring flexible

ATTENTION: Please specify in inquiries and spare part orders always the serial numbers of your machines (→ Section 3.1)!

SPARE PARTS FLIP®

ATTENTION: Please specify in inquiries and spare part orders always the serial numbers of your machines (→ Section 3.1)!

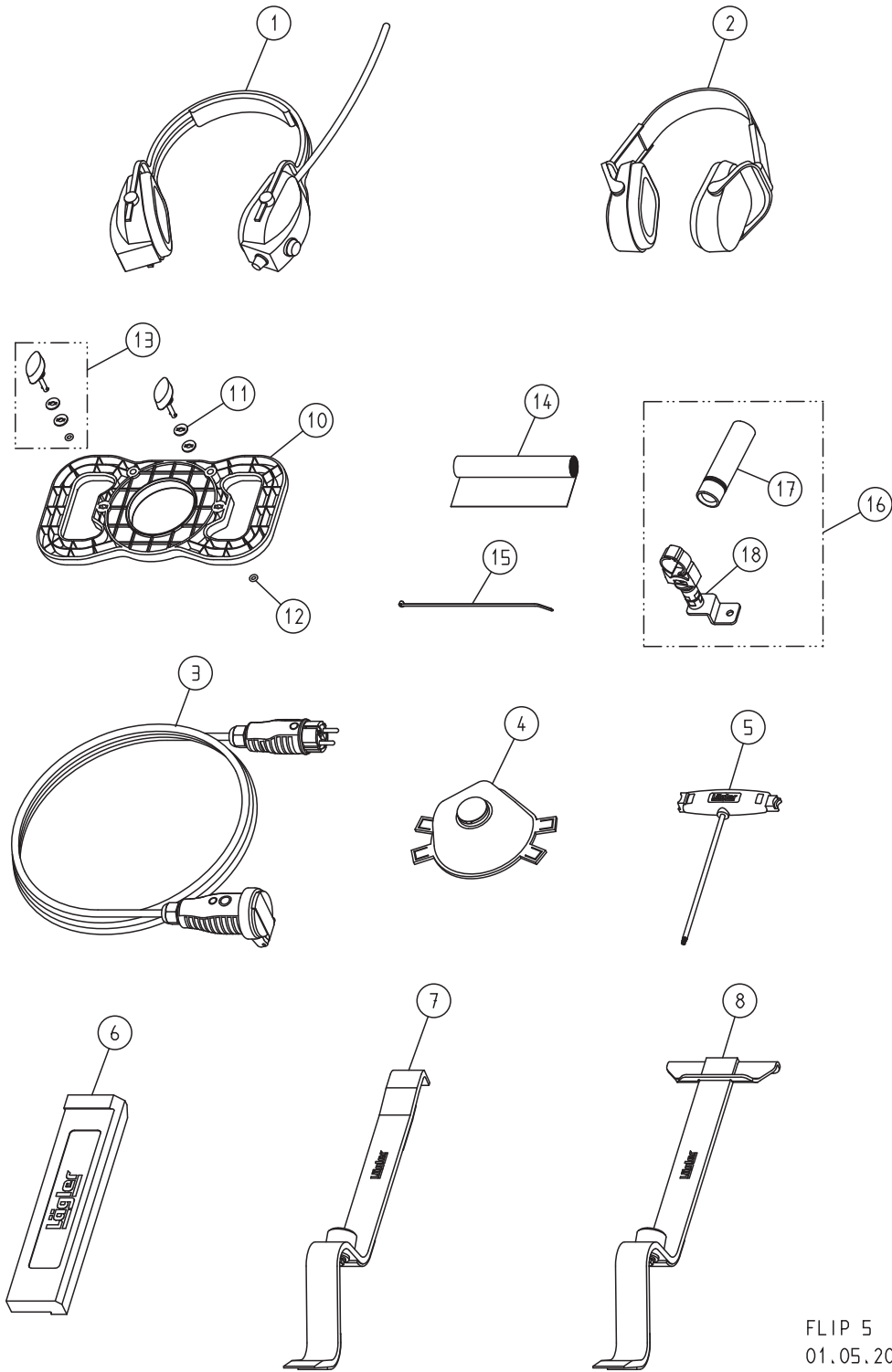

FLIP 5  
01.05.2015

## SPARE PARTS FLIP®

Item	Part number	Description
1	000.01.10.011	Foldable earmuff type MUSIMUFF with FM radio
2	000.01.10.021	Foldable earmuff type POCKET
3	000.65.53.151	Extension cable 3 x 1.5 mm <sup>2</sup> , 10 m long
4	000.01.20.010	Respiratory protection mask P3
5	000.91.40.001	Universal spanner
6	701.10.00.100	Impact tool
7	702.00.00.200	Parquet layer tool ZUGEISEN, small
8	703.00.00.200	Parquet layer tool ZUGEISEN, broad
10	320.00.70.100	Emptying fixture, complete
11	000.10.10.055	Washer
12	000.11.05.901	O-ring
13	000.25.11.433	Locking pin
14	00.000.25.570	Waste bag
15	000.61.10.363	Cable tie
16	320.63.00.100	Working light FLIP®, complete
17	320.63.10.100	Working light FLIP®
18	320.63.20.100	Light bracket FLIP®

ATTENTION: Please specify in inquiries and spare part orders always the serial numbers of your machines (→ Section 3.1)!

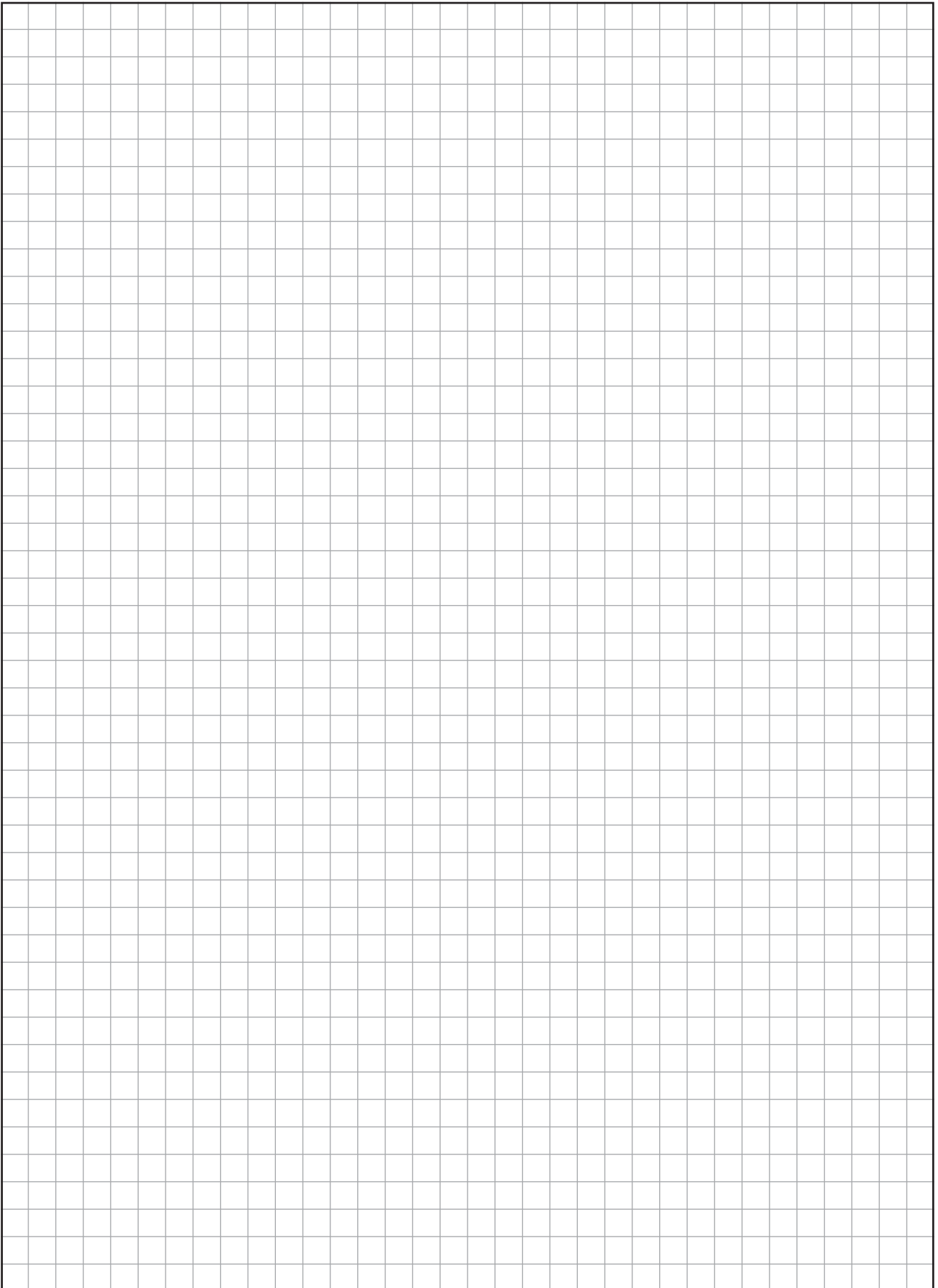

# Service passport

**Please enter the serial number and the year of manufacture of your machine (see type plate) on the rear side of these operating instructions! Otherwise the service passport will not be valid!**

This service passport is a document. Make sure that all the tests and maintenance work carried out on the machine are confirmed by the servicing company here.

<p>Date of test and maintenance work: _____</p>    <p>Signature and company stamp</p>	<p>Date of test and maintenance work: _____</p>    <p>Signature and company stamp</p>	<p>Date of test and maintenance work: _____</p>    <p>Signature and company stamp</p>
<p>Date of test and maintenance work: _____</p>    <p>Signature and company stamp</p>	<p>Date of test and maintenance work: _____</p>    <p>Signature and company stamp</p>	<p>Date of test and maintenance work: _____</p>    <p>Signature and company stamp</p>
<p>Date of test and maintenance work: _____</p>    <p>Signature and company stamp</p>	<p>Date of test and maintenance work: _____</p>    <p>Signature and company stamp</p>	<p>Date of test and maintenance work: _____</p>    <p>Signature and company stamp</p>
<p>Date of test and maintenance work: _____</p>    <p>Signature and company stamp</p>	<p>Date of test and maintenance work: _____</p>    <p>Signature and company stamp</p>	<p>Date of test and maintenance work: _____</p>    <p>Signature and company stamp</p>
<p>Date of test and maintenance work: _____</p>    <p>Signature and company stamp</p>	<p>Date of test and maintenance work: _____</p>    <p>Signature and company stamp</p>	<p>Date of test and maintenance work: _____</p>    <p>Signature and company stamp</p>

# EU Declaration of conformity for machines (EU Directive 2006/42/EC)

The manufacturer **Eugen Lägler GmbH, Kappelrain 2, D-74363 Güglingen-Frauenzimmern, Germany**  
 Tel.: 0049 - 7135 - 98 90-0 · Fax: 0049 - 7135 - 98 90-98  
 E-Mail: info@laegler.com · http://www.laegler.com

certified herewith, that the machine Generic denomination: **Floor sanding machine**  
 Function: **Dry sanding of wooden floors, wooden stairs**  
 Model: **FLIP®**  
 Serial number: **See type plate**  
 Commercial name: **Edge-, corner- and stair-sanding machine**

fulfils all the relevant provisions of the specified above European Directive.

The machine also fulfils all the relevant provisions of the European Directive  
**Electromagnetic compatibility (2014/30/EU).**

**The following harmonized standards have been applied:**

**DIN EN ISO 12100:** Safety of machinery - General principles for design - Risk assessment and risk reduction

**DIN EN 60204-1:** Safety of machinery - Electrical equipment of machines - Part 1

**DIN EN 55014-1:** Electromagnetic compatibility - Requirements for household appliances, electric tools and similar apparatus - Part 1

**DIN EN 55014-2:** Electromagnetic compatibility - Requirements for household appliances, electric tools and similar apparatus - Part 2

**DIN EN 61000-3-2:** Electromagnetic compatibility (EMC) - Part 3-2: Limits

**DIN EN 61000-3-3:** Electromagnetic compatibility (EMC) - Part 3-3: Limits

Güglingen-Frauenzimmern, September 1, 2016

*Volker Wörner*

Volker Wörner, Development Department  
 Person Responsible for Documents  
 Eugen Lägler GmbH, Kappelrain 2  
 D-74363 Güglingen-Frauenzimmern  
 Germany

**FLIP®**

**Serial number:**

**Year of manufacture:**

\_\_\_\_\_

\_\_\_\_\_

**Lägler**  

[www.laegler.com](http://www.laegler.com)