



English / Englisch

Operating Instructions

Translation of original operating instructions
for the belt sanding machine

HUMMEL®

Lägler
www.laegler.com

00.100.20.002 01.01.2017





CONTENTS

1	Introduction.....	5
1.1	Features of the machine	5
1.2	Description of the machine	5
1.3	Intended use of the machine.....	5
1.4	Safety devices.....	6
1.5	Machine configuration.....	6
1.5.1	Basic equipment.....	6
1.5.2	Optional equipment.....	7
1.5.3	Wearing parts and safety-related parts	7
2	Hazard warnings and safety instructions	8
2.1	Hazard warnings.....	8
2.2	General safety instructions	12
3	Technical data	14
3.1	Data on type plate	14
3.1.1	Machine type plate	14
3.1.2	Motor type plate	15
3.2	Machine data	16
4	Commissioning	18
4.1	Preparing the machine for operation	18
4.2	Connecting the power cable	21
4.3	Switching on the machine	22
4.3.1	Machines with single-phase AC motor (mains voltage 230 V and 220 V)	22
4.3.2	Machines with three-phase AC motor (mains voltage 400 V)	22
4.3.3	General.....	23
4.4	Switching off the machine.....	24
5	Working with the HUMMEL®	25
5.1	Application tips.....	25
5.2	Regulating the sanding drum pressure	26
5.3	Changing the sanding belt.....	26
5.4	Emptying the dust bag.....	29
6	Transport and storage.....	31
6.1	Dismantling the machine before transportation	32
6.2	Assembly after transportation	35
6.3	Storage	36

CONTENTS

7	Maintenance work and replacement of wearing parts	37
7.1	Cleaning and care instructions	38
7.1.1	General	38
7.1.2	Dismantling and cleaning of drive unit	39
7.2	Lubrication	41
7.3	Checking and setting the sanding belt tracking	41
7.3.1	Checking the sanding belt tracking	42
7.3.2	Setting the sanding belt tracking	43
7.4	Checking the machine setting	44
7.5	Checking the dust pick-up	46
7.6	Replacement of sanding drum	46
7.7	Replacement of tensioning roller	47
7.8	Replacement of rear wheel	48
7.8.1	Replacement of rear wheel only	48
7.8.2	Replacement of complete rear wheel assembly	49
7.9	Replacement of lateral wheels	50
7.10	Replacement and tensioning of V-belts	51
7.10.1	Replacement of V-belts	51
7.10.2	Tensioning of V-belts	52
8	Regular maintenance and testing in accordance with accident prevention regulations	55
9	Causes of faults	57
9.1	The machine does not run or has switched off automatically	57
9.2	The machine attempts to start up but is not able to do so	58
9.3	The machine runs but has no or very little sanding power capacity	59
9.4	The machine vibrates intensely and runs noisily	60
9.5	The machine runs but creates a great deal of dust	60
9.6	Sanding problems (waves, strips, grooves)	61
10	Circuit diagrams	63
11	Spare parts HUMMEL®	66
12	Service passport	79
13	EU Declaration of conformity for machines (EU Directive 2006/42/EC)	80

Safety notes used in this operating instructions and their meaning:

 <u>WARNING!</u>	Death, severe physical injury or significant property damage can occur if the corresponding cautionary measures are not taken!
 <u>CAUTION!</u>	Moderate to light physical injury or property damage can occur if the corresponding cautionary measures are not taken!
<u>ATTENTION!</u>	An undesired event can occur if the corresponding instructions are not followed!

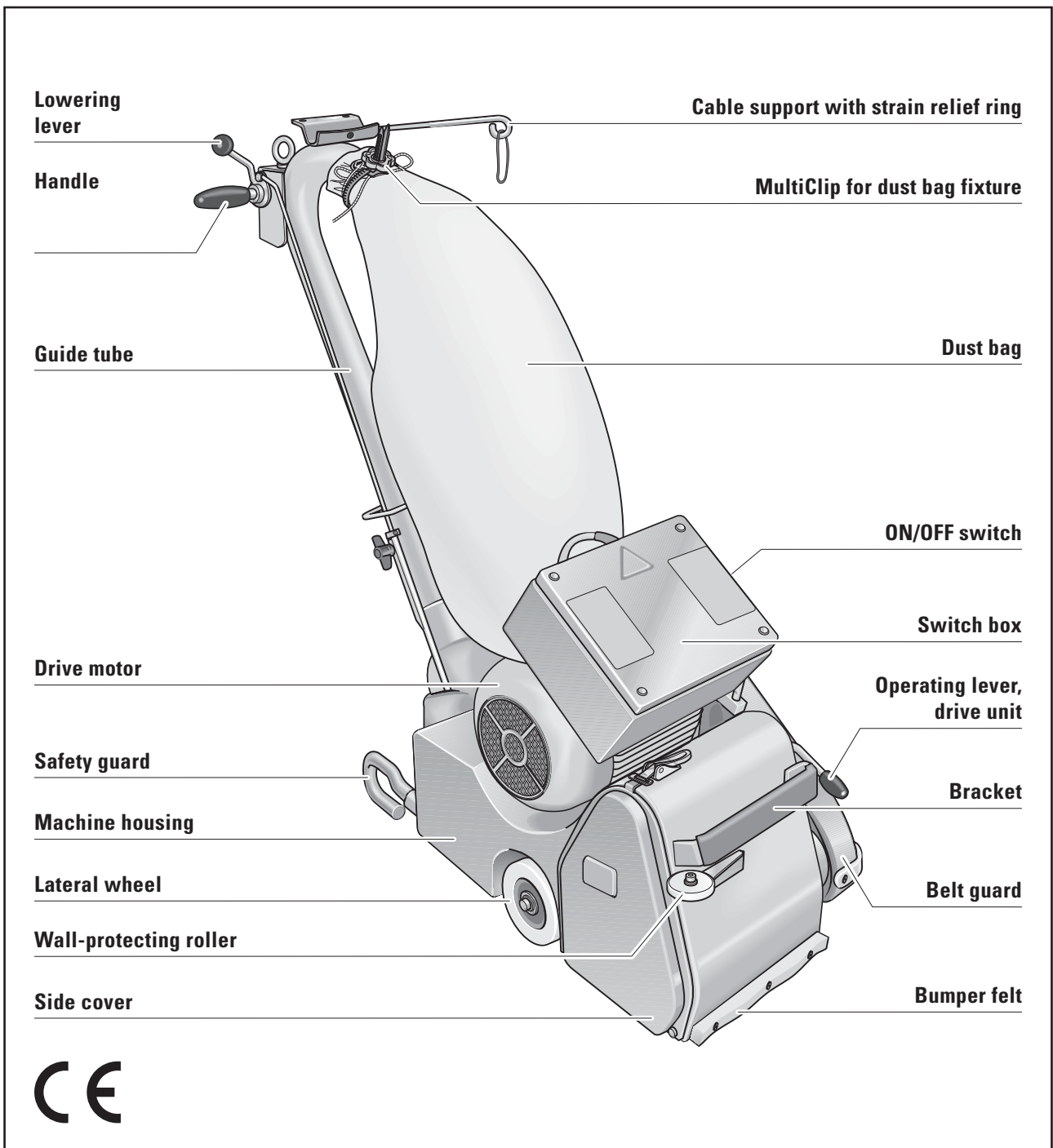

Fig. 1 Main features of the belt sanding machine HUMMEL®.

Introduction

1.1 FEATURES OF THE MACHINE

Figure 1 shows the most important components which make up the HUMMEL®. We recommend that you take some time to become familiar with the machine.

1.2 DESCRIPTION OF THE MACHINE

The HUMMEL® belt sanding machine operates with a contact sanding drum featuring a specially profiled rubber coating. The belt tensioning fixture with integrated automatic belt guidance is located vertically above the sanding drum. The work zone is covered by the machine housing and detachable side cover. On the machine housing, the electric motor is fixed in a motor bearing bracket. The plug for connection to the mains is located at the switch box of the motor. The motor switch with the switch positions START / WORKING and TEST is located at the switch box. On the left under the belt guard is the belt drive unit. The machine is moved by means of a steering wheel at the back and two lateral wheels. Two handles are attached to the guide tube, where the drum lowering lever is also located and the cables and dust bag are attached.

1.3 INTENDED USE OF THE MACHINE

The HUMMEL® belt sanding machine is suitable for dry sanding wooden and cork floors, plastic skating rinks and tartan running tracks.

A specially equipped version of the machine can be used to sand sheet metal surfaces.

Any application other than that described here is inadmissible without the consent of the manufacturer!

You have purchased a high-quality product from LÄGLER®. We wish you a great deal of success with your HUMMEL®. All LÄGLER® products are subjected to a thorough inspection before leaving the factory.

Please read these operating instructions completely before you begin working with your HUMMEL®. These operating instructions include important information on occupational safety and will provide you with answers to many questions so that you can work with the machine safely and without any problems. If you cannot find a specific subject in these operating instructions, please read the LÄGLER® application technique guidelines "Sanding of wooden floors" (<http://www.laegler.com>) or contact our service department, your retailer or your importer.



WARNING!

RISK OF DEATH from electrical shock:

The machine may never be used for wet processing operations of any kind!

INTRODUCTION

1.4 SAFETY DEVICES

The following parts of the machine are safety devices and must accordingly be kept in perfect working order:

Sealing felt	=	Dust shield
Side cover	=	Dust shield, sanding belt protection
Machine housing	=	Sanding belt protection
Belt guard	=	V-belt protection

1.5 MACHINE CONFIGURATION

1.5.1 BASIC EQUIPMENT

- 1 Machine ready for operation
- 1 Operating instructions
- 1 Dust bag
- 1 MultiClip for dust bag fixture
- 1 Cable support
- 1 O-ring as a strain relief device
- 1 Extension cable, length 10 m (394"):
for single-phase AC motor 3 x 2.5 mm² (3 x 0.0039 sq.in.)
for three-phase AC motor 5 x 1.5 mm² (5 x 0.0023 sq.in.)
- 1 Tool bag
- 1 Closed mouth wrench, size 13 mm and size 10 mm
- 1 Open mouth wrench, size 17 mm
- 1 Hexagonal socket wrench, size 4 mm
- 1 Hexagonal socket wrench, size 5 mm
- 1 Hexagonal socket wrench, size 6 mm
- 1 Setting fixture
- 1 Box wrench
- 1 Respiratory protection mask, filter class P3

1.5.2 OPTIONAL EQUIPMENT

- Carrying handle
- TransCart
- Safety belt
- Foldable earmuff
- Safety switch for fault current PRCD-S (for German mains supply)

NOTE:

You will find the corresponding part numbers for the optional equipment and wearing parts in *Section 11, Spare parts HUMMEL®*.

1.5.3 WEARING PARTS AND SAFETY-RELATED PARTS

Check the condition of the wearing parts and the safety-related parts mentioned below at regular intervals in order to be able to work safely and optimally at all times.

Replace the following parts in case of wear and/or damage:

- Extension cable
- Motor cable
- ON/OFF switch
- Sealing felt
- MultiClip
- V-belts
- V-belt pulleys
- Belt tensioner
- Sanding drum
(in case of daily use, exchange every 1 - 2 years)
- Tensioning roller of the drive unit
(in case of daily use, exchange every 1 - 2 years)
- Guide rollers at the drive unit
- Guide roller at the machine housing
- Side cover
- Dust bag
- O-ring used as a strain relief
- Rear wheel
- Lateral wheels

Hazard warnings and safety instructions



WARNING!

RISK OF DEATH, RISK OF INJURY, RISK OF FIRE:

- **Be certain to read the hazard warnings and safety instructions before using the machine!**
- **Instruct your co-workers and colleagues accordingly! Otherwise these persons could be exposed to danger or injured!**
- **Keep these hazard warnings and safety instructions in a safe place!**
- **Observe the applicable regulations and legal requirements in your country!**

2.1 HAZARD WARNINGS



WARNING!

RISK OF DEATH from suffocation and RISK OF INJURY:

- **Never** wrap the power cable around your neck or other parts of the body!

RISK OF DEATH from electrical shock:

- The machine may **never** be used for wet processing operations of any kind!
- Do not expose the machine to rain! Do not use the machine in moist or wet environments!
- Do not connect the machine on hazardous electrical power sources! Only use safety sockets!
- To protect yourself and the machine against faults in the mains supply use a safety switch (for German mains supply → part number in *Section 11, Spare parts HUMMEL®*)! **Observe the applicable regulations and legal requirements in your country!**
- All extensive maintenance work, especially on the electrical equipment, **must** be conducted by a qualified expert for safety reasons!
- The machine **must** be switched off and the power plug **must** be removed from the socket during all maintenance work and all work on the electrical equipment!
- Avoid body contact with grounded parts, e.g. pipes, radiators, ovens, refrigerators!
- The quality of the motor cable and the power cables **must** match the quality of the original LÄGLER® cables!
- The motor cable and the power cables must be protected from mechanical and electrical damages in the workplace!
- Do not carry or pull by the machine by the cable! Do not pull on the cable to remove the plug from the socket! Protect the cables against heat, oil and sharp edges!

**WARNING!****RISK OF DEATH from unsecured load:**

- When transported in a car or the like, the machines and all parts must be secured against sliding!

RISK OF EXPLOSION due to sparks while sanding or a high dust concentration in the air:

- Do not use the machine near
 - sources of fires,
 - flammable liquids or gases,
 - potentially explosive areas!
- Do not smoke in a dusty environment, e.g. while sanding or emptying the dust bag!

RISK OF FIRE from sparks while sanding or from spontaneous combustion:

- Prior to sanding a nailed or screwed floor all nails or screws must be countersunk deeply enough so that they cannot be sanded:
 - Countersink the nails for example with a hammer and a punch!
 - Tighten the screws!
- There is a high risk of fire when sanding woods with a large amount of resin, oiled or waxed floors or metal! Therefore, the machine must **always** be cleaned carefully directly after sanding! **Be certain** to note the warning notices of the manufacturers of paint, oil and wax!
- Cloths, pads, et cetera which have been immersed in oil or wax can spontaneously combust! **Be certain** to note the warning notices of the manufacturers of paint, oil and wax!
- The dust bag must **always** be removed from the machine **directly** after sanding and emptied into a **non-combustible** container **outdoors**! Cover this container with a **non-combustible** cover and **be certain** to store it and the dust bag **outdoors** in **non-combustible** environment (→ *Section 5.4, Emptying the dust bag*)!
- Always transport and store used dust bags in **closed** and **non-combustible** containers!
- Always transport and store the machine **without** dust bag!

**WARNING!****RISK OF FIRE from the overheating of the cables:**

- Only the following motor cables and power cables may be used:
 - Machines with motor for mains voltage **220 V** or **230 V**:
Cables with three wires and wire cross-sections of at least 2.5 mm² (0.0039 sq.in.)!
 - Machines with motor for mains voltage **400 V**:
Cables with five wires and wire cross-sections of at least 1.5 mm² (0.0023 sq.in.)!
- The maximum cable length in order to connect the machine to the mains supply must not exceed 20 m (790")!

HEALTH RISK caused by dust:

- Make sure that the dust bag is properly fastened to the machine!
- Do not use damaged, washed or repaired dust bags!
- Do not work with an overfilled dust bag (→ *Section 5.4, Emptying the dust bag*)!
- If the machine is operated **correctly**, the mandatory dust emission values will not be exceeded! Empty the dust bag **outdoors**! At the same time a respiratory protective mask (at least filter class P2) **must** be worn!
- A respiratory protective mask (at least filter class P2) must be worn when conducting other work that creates dust, e.g. cleaning of the machine!

**CAUTION!**

RISK OF INJURY and RISK OF PROPERTY DAMAGE from rotating tools and parts of the machine:

- For all operating conditions of the machine only one operator is required! As a consequence, for safety reasons only **one person** must be in the working area while operating the machine!
- Before switching on the machine, make sure that all tools and adjustment tools have been removed from the machine!
- The machine **may not be started** when tilted backward or forward!
- The machine **may not be started** if the sanding drum is on the floor!
- **Never** leave the operational machine unattended!
- Do not reach into rotating tools or parts of the machine!
- Do not let children or other persons touch the machine or cables and keep them out of the work area!
- Do not wear any long articles of clothing or jewellery! These could be caught by moving parts!

RISK OF INJURY and RISK OF PROPERTY DAMAGE from unintentional starting of the machine:

- The power plug **must always** be removed from the socket when the machine is switched off!
- Make sure that ON/OFF switch is not set to ON when connecting the machine to the mains supply!

RISK OF INJURY and RISK OF PROPERTY DAMAGE from the rolling away, tipping or falling of the machine:

- The machine must be secured against rolling away, tipping or falling when not in use!
- **Always** ensure that the machine is standing securely!

RISK OF INJURY and RISK OF PROPERTY DAMAGE from unsuitable parts:

- Only use tools, accessories and spare parts from LÄGLER® for the HUMMEL® (→ *Section 11, Spare parts HUMMEL®*)! **Warranty claims for foreign parts or damage caused thereby cannot be accepted!**

**CAUTION!****HEALTH RISK caused by noise:**

- Use hearing protection when conducting work that produces noise! Observe the applicable regulations and legal requirements in your country!

RISK OF PROPERTY DAMAGE:

- Never use any cleaning products which contain solvents!
- Do not store the unused machine on the sanding drum! Otherwise the sanding media can cause scratches on the ground or the sanding drum can be damaged!
- Never conduct a maintenance or a replacement of wearing parts on the newly sanded wooden floor! Thus, you will avoid scratches or other damage to the floor!
- Improper transport will result in damage to the machine!

2.2 GENERAL SAFETY INSTRUCTIONS

- **Check your machines for damage!**

Before using the machines, you must inspect the safety devices carefully to ensure that they are working perfectly and as intended.

Check whether the moving parts are working properly, that they are not sticking, that no parts are broken, whether all parts are in perfect condition and installed properly and whether all other conditions which could influence the operation of the machine are in order.

Damaged safety devices and parts must be replaced by an authorized service shop insofar as nothing to the contrary is indicated in the operating instructions.

Regularly inspect the motor cable and have it replaced by a qualified electrician if it is damaged. Inspect the extension cable regularly and replace it if it is damaged (➔ part numbers in *Section 11, Spare parts HUMMEL®*).

Damaged electrical components must be replaced by a qualified electrician (➔ part numbers in *Section 11, Spare parts HUMMEL®*).

Do not use the machine if it cannot be switched on and/or switched off by using its switch.

- **Maintain your machines with care!**
 - Keep your machines clean so that you can work better and more safely.
 - Follow the maintenance guidelines and the instructions for replacing tools.
 - Keep the handles dry and free of oil and grease.

- **Provide good illumination in the workplace!**

Well lit construction sites reduce the risk of injury and allow you to better evaluate the quality of your work.

- **Keep your work area tidy!**

Untidy work areas create a risk of accidents.

- **Use the proper machines!**

Do not use low-performance machines or additional devices for heavy jobs. Do not use the machine for purposes and work that it is not intended for.

- **Do not overload the machines!**

It works better and more safely in the power range noted.

- **Do not bend too far over the machine!**

Avoid unnatural postures. Make sure that you stay in a stable position and keep your balance at all times.

- **Be attentive!**

Pay attention to your work. Work carefully and do not use the machines if you are not concentrating.

- **Store your machines safely!**

Store your unused machines in a dry, closed location out of the reach of children!

Technical data

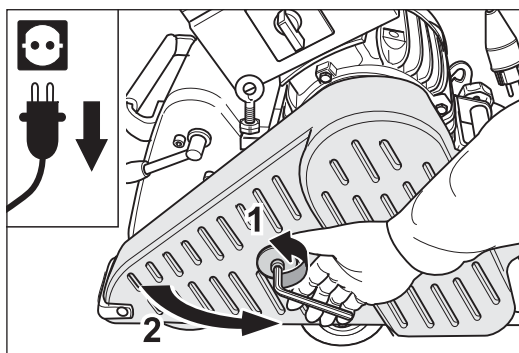

Fig. 2 Pull the power plug out of the socket and open the belt guard.

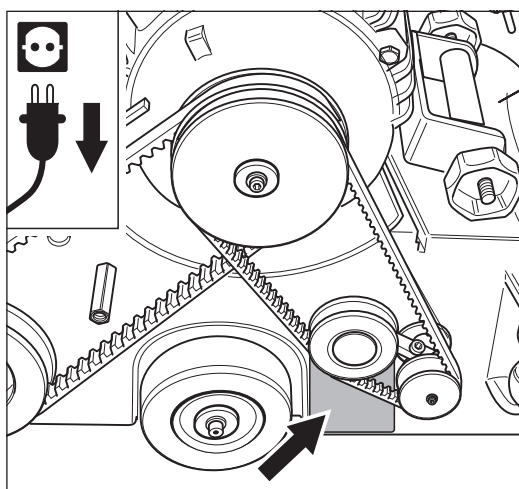

Fig. 3 Machine type plate on machine housing.

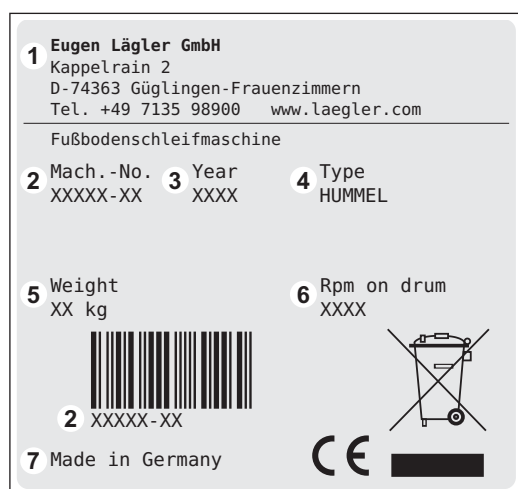

Fig. 4 Data on machine type plate.

3.1 DATA ON TYPE PLATE

ATTENTION!

In order to receive the correct spare parts from us, please specify in inquiries and spare part orders always the serial numbers of your machines!

3.1.1 MACHINE TYPE PLATE

In order to be able to read the machine type plate of the HUMMEL®, proceed as follows:

- 1 The machine **must be switched off** (→ *Section 4.4, Switching off the machine*)!
- 2 **Pull the power plug out of the socket!**
- 3 Open the belt guard (fig. 2)
- 4 The machine type plate is located on the machine housing below the belt tensioner (fig. 3).

The following technical data are specified on the machine type plate (fig. 4):

- 1 Manufacturer
 - 2 **Serial number of machine (Mach.-No.)**
 - 3 Year of manufacture (Year)
 - 4 Machine name (Type)
 - 5 Weight of machine in kilogram (Weight)
 - 6 Speed of sanding drum in 1/min (Rpm on drum)
 - 7 Country of manufacture
- 5 **Close the belt guard (fig. 5)!**

3.1.2 MOTOR TYPE PLATE

The motor type plate of the HUMMEL® is located on the switch box of motor (fig. 6).

The following technical data are specified on the motor type plate (fig. 7):

- 1 Manufacturer
- 2 **Serial number of machine (Mach.-No.)**
- 3 Year of manufacture (Year)
- 4 Motor size (Type)
- 5 Required mains voltage in volt (V)
- 6 Current consumption in ampere (A)
- 7 Motor frequency in CPS (Hz)
- 8 Motor power in kilowatt (KW)
- 9 Motor speed in 1/min (Rpm)
- 10 Power factor cos phi (cos)
- 11 Insulation class (Insul. Cl.)
- 12 Protection class (Prot. Cl.)
- 13 Type of current
- 14 Country of manufacture

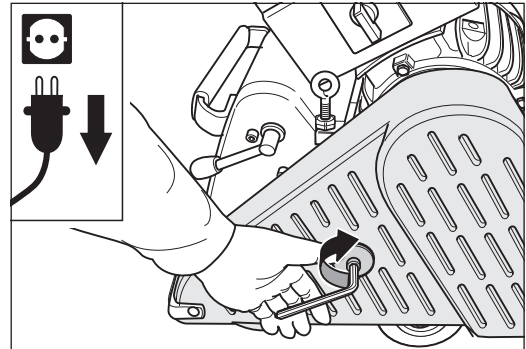

Fig. 5 Close the belt guard.

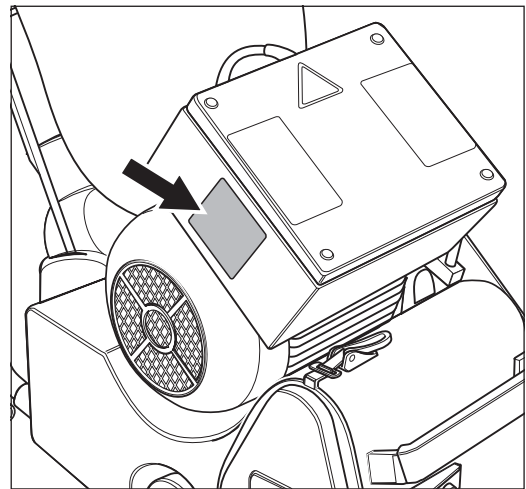

Fig. 6 Motor type plate on switch box.

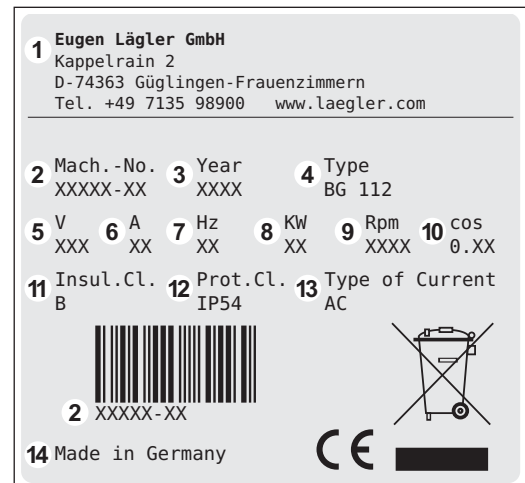

Fig. 7 Data on motor type plate.

3.2 MACHINE DATA

Manufacturer	Eugen Lägler GmbH
Machine type	belt sanding machine
Machine name	HUMMEL®
Serial number	see type plate (fig. 3, fig. 6)
Year of manufacture	see type plate (fig. 3, fig. 6)

NOTE:

The motor data indicated here refers to machines used in Germany or USA. Exported machines may have other data that can be seen on the motor type plate.

Motor type	single-phase AC motor		
Voltage	230 V	220 V 230 V	220 V (USA version)
Frequency	50 Hz (CPS)	60 Hz (CPS)	60 Hz (CPS)
Motor power	2.2 kW		2.9 kW
Necessary fuse protection of mains supply	at least 16 A	at least 20 A	at least 20 A
Starting capacitor	60 µF		130 µF
Running capacitor	40 µF		40 µF

Motor type	three-phase AC motor
Voltage	400 V
Frequency	50 Hz (CPS)
Motor power	4.0 kW
Necessary fuse protection of mains supply	at least 16 A

Insulation class	B
Protection class	IP 54
Safety devices	no-voltage release, temperature switch as overload protection in the motor

Diameter of sanding drum	175.5 mm (approx. 6.9")
Width of sanding drum	200 mm (approx. 7.9")
Speed of sanding drum - machine with motor 50 Hz (CPS) - machine with motor 60 Hz (CPS)	approx. 2400 1/min (rpm) approx. 2810 1/min (rpm)
Dimension of sanding belt	200 x 750 mm (approx. 7.9" x 29.5")

TECHNICAL DATA

Overall length of machine	1040 mm (approx. 40.9")
Overall width of machine	360 mm (approx. 14.2")
Overall height of machine	1020 mm (approx. 40.2")
Weight of machine housing	41 kg (approx. 90 lbs)
Weight of motor	34 kg (approx. 75 lbs)
Weight of guide tube, complete	4 kg (approx. 9 lbs)
Overall weight of machine	79 kg (approx. 174 lbs)

Dust emissions at workplace (Operation of the machine according to the operating instructions)	< 1 mg/m ³ (approx. 0.012 gr./cu.yd.)
Workplace-related noise emission values	76 dB(A)
Measurement uncertainty constant of the noise emission values	4 dB(A)
Vibration total value a_{HV} (measured at the handle)	< 2.5 m/s ²

NOTE on noise emission:

The values indicated are emission values and must not represent safe workplace values as well.

Although a correlation exists between emission levels and immission levels, it is not always possible to determine whether additional precautionary measures are required.

Factors that can have an effect on the immission level existing at the workplace include the duration of the effects, the characteristics of the work area and other sources of noise, e.g. the number of machines and processing operations in the vicinity. The permissible workplace values may also vary from country to country.

This information, however, is intended to enable the user to better estimate the dangers and risks.

Commissioning

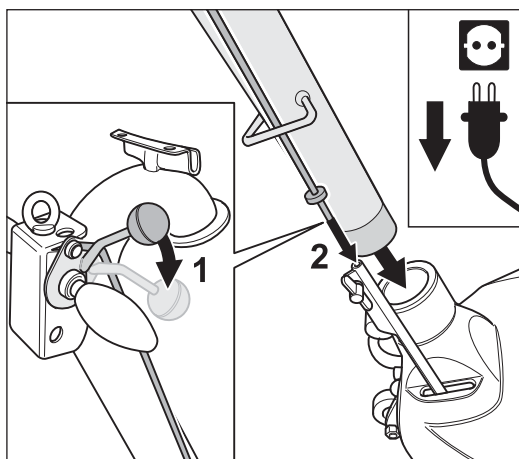

Fig. 8 When inserting the guide tube, make sure that the upper rod of the lowering mechanism feeds in correctly!

This section describes the procedure for commissioning the HUMMEL® on site. In order to exclude the possibility of damage and malfunctions, it is essential to proceed in the sequence outlined below.



CAUTION!

RISK OF INJURY and RISK OF PROPERTY DAMAGE:

Before working with the machine for the first time, operating staff must be adequately instructed!

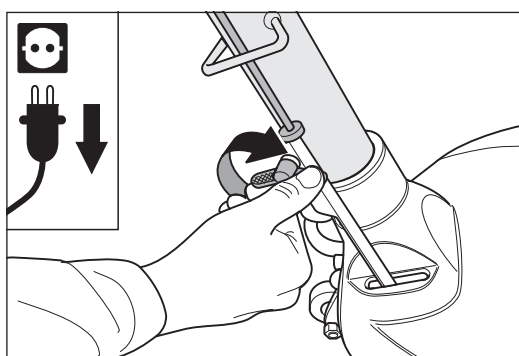

Fig. 9 After inserting the guide tube, carefully tighten the wing screw at the lower rod.

4.1 PREPARING THE MACHINE FOR OPERATION

- 1 Unpack the machine carefully. The bottom part of the supplied transport crate makes a useful container for storage or transportation of the machine (→ *Section 6, Transport and storage*). Please ensure that the packaging materials are responsibly disposed of.
- 2 Press the lowering lever at the handle downwards (fig. 8, 1).
- 3 Insert the guide tube into the opening in the machine housing and at the same time insert the upper rod into the lower rod (fig. 8, 2).
- 4 Carefully tighten the wing screw at the lower rod (fig. 9) and the wing nut at the machine housing (fig. 10).

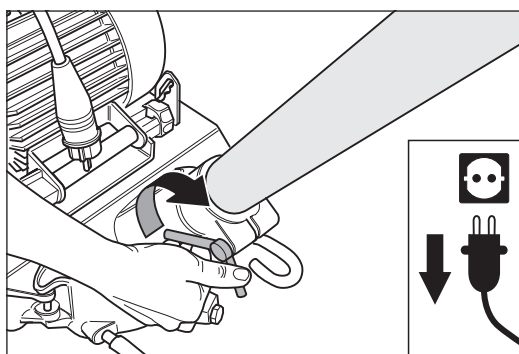

Fig. 10 After inserting the guide tube, carefully tighten the wing nut at the machine housing.

- 5 Lift the sanding drum off the floor by turning the lowering lever at the handle upwards (fig. 11).
- 6 Hook the cable support into the bracket at the top of the guide tube (fig. 12)
- 7 Fasten the dust bag firmly using the cord and the MultiClip at the end of the guide tube (fig. 13). Ensuring when mounting that the opening of the guide tube is not closed.
- 8 Release the cover lock (fig. 14, 1) and remove the side cover on the right of the machine housing (fig. 14, 2).
- 9 Pull the operating lever of the drive unit upwards (fig. 14, 3). This will lower the tensioning roller.
- 10 Position the sanding belt on the tensioning roller of the drive unit (fig. 15) and push it over the tensioning roller and the sanding drum (fig. 16).

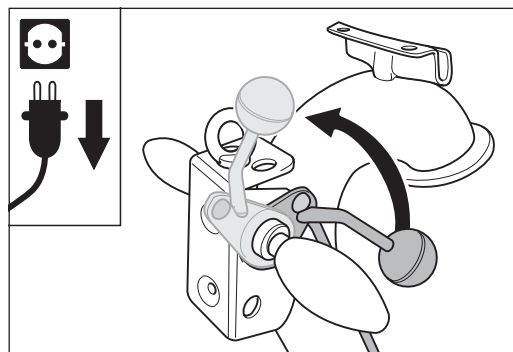

Fig. 11 Lift the sanding drum off the floor by turning the lowering lever at the handle upwards.

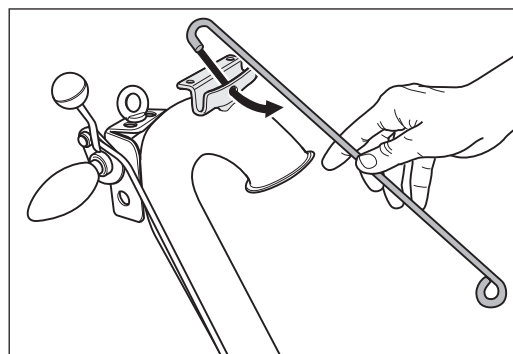

Fig. 12 Hook the cable support into the bracket at the guide tube.

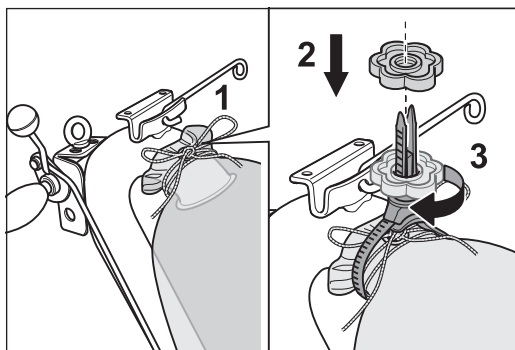

Fig. 13 Mount the dust bag using the cord (1) and the MultiClip (2 and 3) at the end of the guide tube.

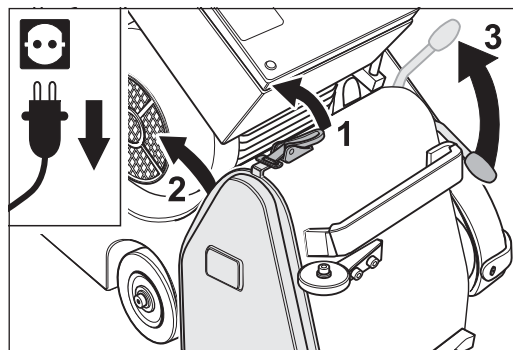

Fig. 14 Release the cover lock (1), remove the side cover (2) and lower the tensioning roller by pulling up the operating lever (3).

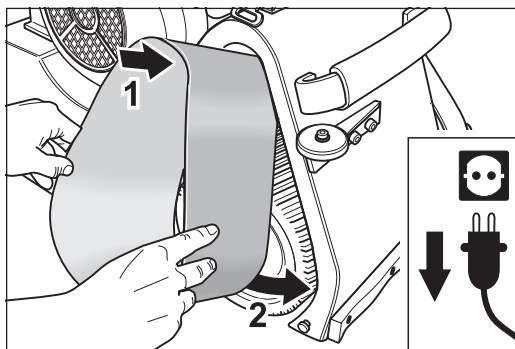

Fig. 15 Position the sanding belt on the tensioning roller of the drive unit.

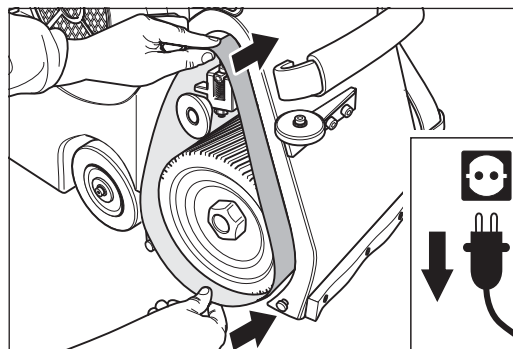

Fig. 16 Push the sanding belt far enough over the sanding drum and tensioning roller so that the sanding drum is fully covered by the sanding belt.

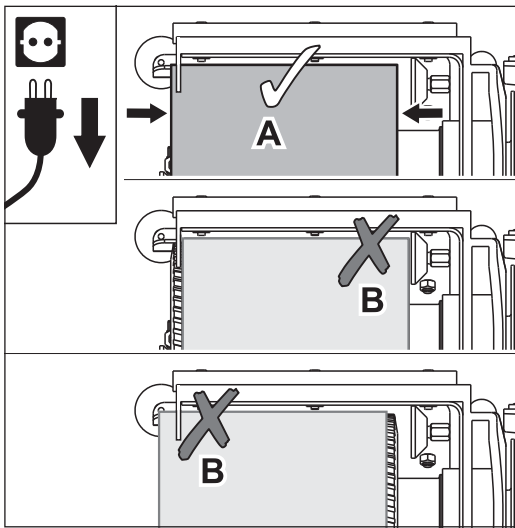

Fig. 17 Position the sanding belt so that it evenly covers the sanding drum (A). Avoid position B without fail (RISK OF FIRE)!

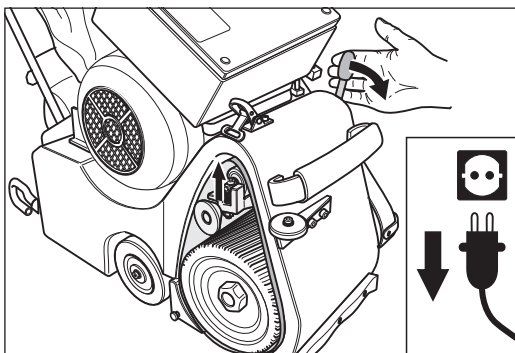

Fig. 18 Tension the sanding belt by lowering the operating lever. Otherwise, damage or injury can occur!

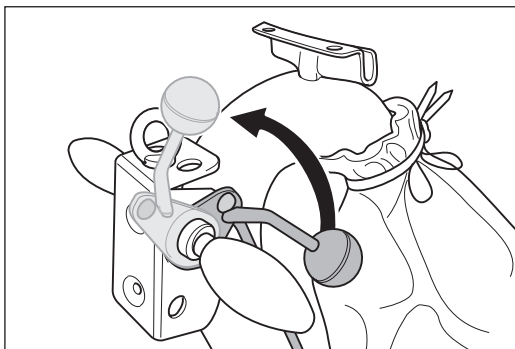

Fig. 19 Lift the sanding drum off the floor by turning the lowering lever at the handle upwards.

- 11 Position the sanding belt so that it evenly covers the sanding drum (fig. 17, A).



WARNING!

RISK OF FIRE from the formation of sparks while sanding:

Position B of the sanding belt in fig. 17 provoke sparking during sanding! Avoid this without fail!

- 12 To tension the sanding belt, press the operating lever of the drive unit downwards (fig. 18). **Otherwise, damage or injury can occur!**
- 13 Connect the machine to the mains supply (→ Section 4.2, Connecting the power cable).
- 14 **Before sanding, the precise tracking of the sanding belt must be checked! Adjusted it if necessary (→ Section 7.3, Checking and setting the sanding belt tracking)!**



CAUTION!

RISK OF INJURY and **RISK OF PROPERTY DAMAGE** from rotating parts of the machine:

- **Always** tension the sanding belt before switch on the machine (fig. 18)!
- **Always** lift the sanding drum off the floor before switch on the machine (fig. 19)!
- **Never** reach into the area of the sanding belt while it is running!
- **During the test run, ensure that no objects randomly positioned in the vicinity can be picked up by the sanding belt and no other persons are in the danger area!**

- 15 After the checking and setting of the sanding belt tracking mount the side cover (fig. 20).
- 16 The machine is now ready for operation (→ Section 4.3, Switching on the machine).

4.2 CONNECTING THE POWER CABLE

**WARNING!****RISK OF DEATH from electrical shock:**

- Do not connect the machine on hazardous electrical power sources! Only use safety sockets!
- To protect yourself and the machine against faults in the mains supply use a safety switch PRCD (for German mains supply → part number in *Section 11, Spare parts HUMMEL®*)!
- Observe the applicable regulations and legal requirements for your country!

RISK OF FIRE from the overheating of the cables:

- Only the following motor cables and power cables may be used:
 - Machines with motor for mains voltage 220 V or 230 V:
Cables with three wires and wire cross-sections of at least 2.5 mm² (0.0039 sq.in.)!
 - Machines with motor for mains voltage 400 V:
Cables with five wires and wire cross-sections of at least 1.5 mm² (0.0023 sq.in.)!
- The maximum cable length in order to connect the machine to the mains supply must not exceed 20 m (790")!

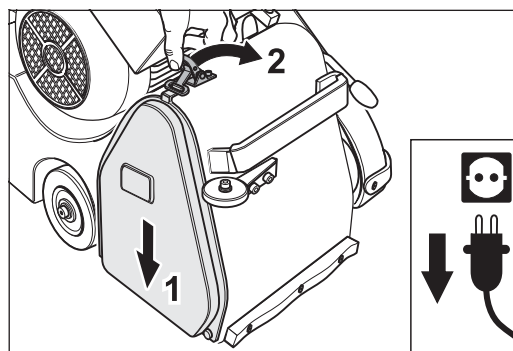

Fig. 20 Mount the side cover.

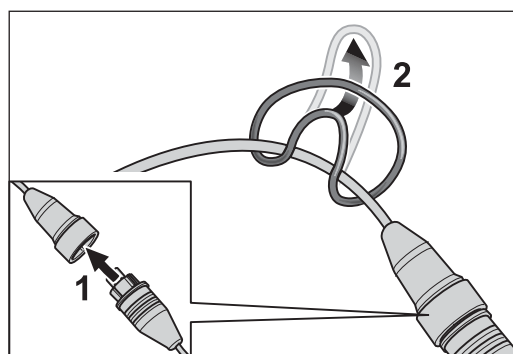

Fig. 21 Insert the plug of the motor cable in the coupler of the extension cable (1). Fasten the strain relief ring on the extension cable (2).

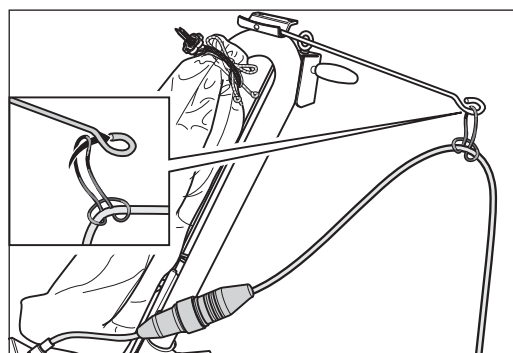

Fig. 22 Mount the strain relief ring on the cable support.

- 1 Lift the sanding drum off the floor by turning the lowering lever at the handle upwards (fig. 19).
- 2 Insert the plug of the motor cable in the coupler of the extension cable (fig. 21, 1).
- 3 Fasten the strain relief ring on the extension cable (fig. 21, 2) and mount the strain relief ring on the cable support (fig. 22).
- 4 Plug in the extension cable to a adequately fused mains socket with PE contacts.

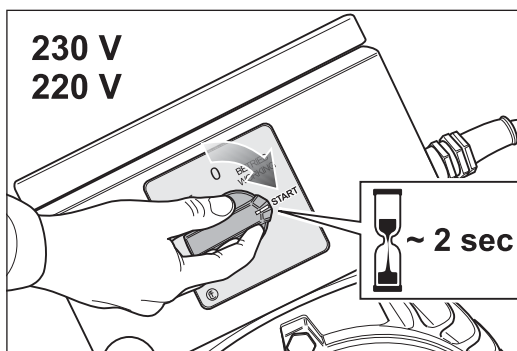

Fig. 23 To switch on the machine turn the switch button at the motor to position -START- and hold the switch button for around 2 seconds in this position.

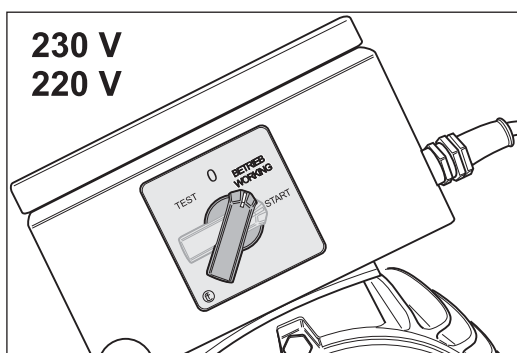

Fig. 24 Once the motor has reached its full speed, release the switch button. The switch button will then automatically move to position -BETRIEB (WORKING)-.

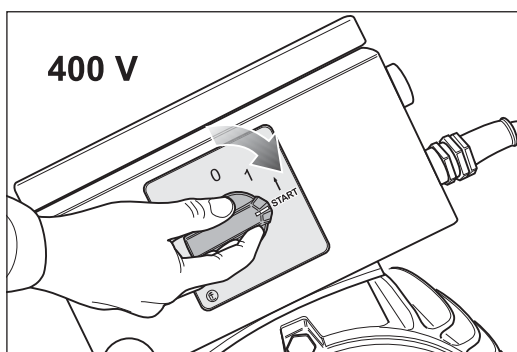

Fig. 25 To switch on the machine turn the switch button at the motor to position -START-.

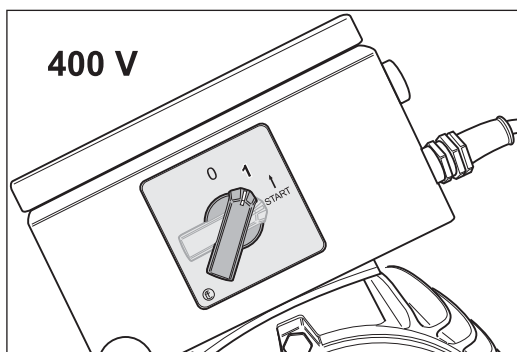

Fig. 26 Release the switch button. The button turns automatically in position -1-.

4.3 SWITCHING ON THE MACHINE



CAUTION!

RISK OF INJURY and RISK OF PROPERTY DAMAGE from rotating parts of the machine:

- **Always** tension the sanding belt before switch on the machine (fig. 18)!
- **Always** lift the sanding drum off the floor before switch on the machine (fig. 19)!
- **Never** allow the machine to run unattended!

4.3.1 MACHINES WITH SINGLE-PHASE AC MOTOR (MAINS VOLTAGE 230 V AND 220 V)

- 1 **Lift the sanding drum off the floor by turning the lowering lever at the handle upwards (fig. 19)!**
- 2 To switch on the machine turn the switch button at the motor to position -START- and hold the switch button for around 2 seconds in this position (fig. 23).
- 3 Once the motor has reached its full speed, release the switch button. The switch button will then automatically move to position -BETRIEB (WORKING)- (fig. 24).

ATTENTION!

Remaining for too long in the switch position -START- shortens the service life of the starting capacitor!

4.3.2 MACHINES WITH THREE-PHASE AC MOTOR (MAINS VOLTAGE 400 V)

- 1 **Lift the sanding drum off the floor by turning the lowering lever at the handle upwards (fig. 19)!**
- 2 To switch on the machine turn the switch button at the motor to position -START- (fig. 25) and release the switch button after the motor has reached its full speed. The switch button will then automatically move to position -1- (fig. 26).

If the motor do not start in the switch position -START- (fig. 27, 1) and the light on the switch box shines (fig. 27, 2), the rotation direction of the motor is wrong.

To change the rotation direction of the motor using the following procedure:

- 1 **Disconnect the motor cable from extension cable!**
- 2 Original LÄGLER® plug with red nut at the cable outlet (fig. 28, A):

- Put a screwdriver in the slit of the phase changing switch in the plug of the motor cable (fig. 29, 1).
- To unlock the phase changing switch press the screwdriver in the slit and at the same time turn the screwdriver 180° (fig. 29, 2).

Original LÄGLER® plug with yellow nut at the cable outlet (fig. 28, B):

- Put a screwdriver in the slit of the phase changing switch in the plug of the motor cable (fig. 29, 1).
- To unlock the phase changing switch turn the screwdriver 180° against a small resistance (fig. 29, 2).

ATTENTION!

The phase changing switch can only be turned in one direction!

4.3.3 GENERAL

If the motor should ever be difficult to start in extremely cold conditions proceed as follows:

- 1 Switch off the machine (➔ *Section 4.4, Switching off the machine*) and remove the V-belts (➔ *Section 7.10, Replacement and tensioning of V-belts*).
- 2 Switch on the machine **without V-belts** (➔ *Section 4.3, Switching on the machine*).
- 3 Once the motor is up to operating temperature, switch off the machine (➔ *Section 4.4, Switching off the machine*) and mount the V-belts (➔ *Section 7.10, Replacement and tensioning of V-belts*).

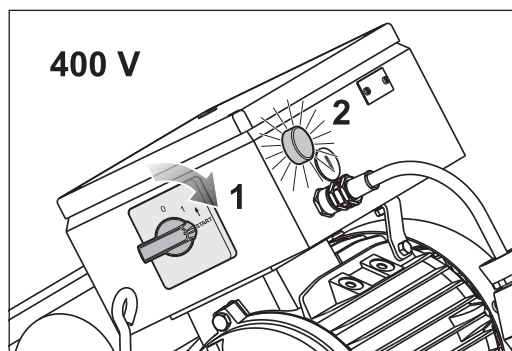

Fig. 27 The motor do not start in switch position -START- (1) and the light on the switch box shines (2).

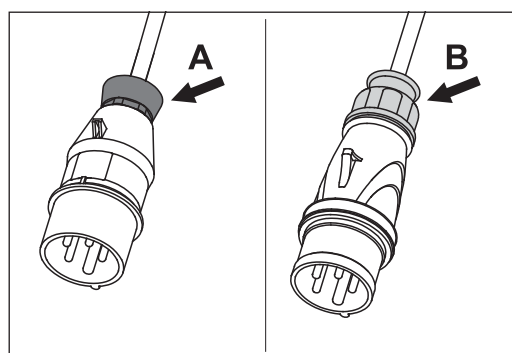

Fig. 28 Original LÄGLER® plug with red nut (A) or yellow nut (B).

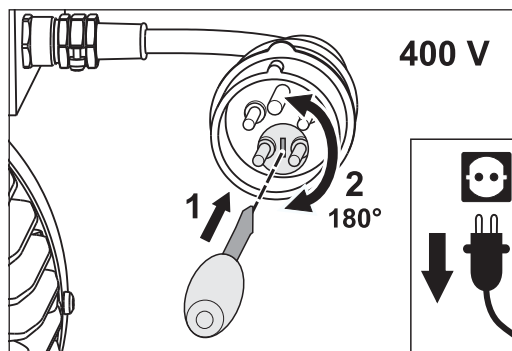

Fig. 29 Change the rotation direction of the motor by turning the phase changing switch 180°.

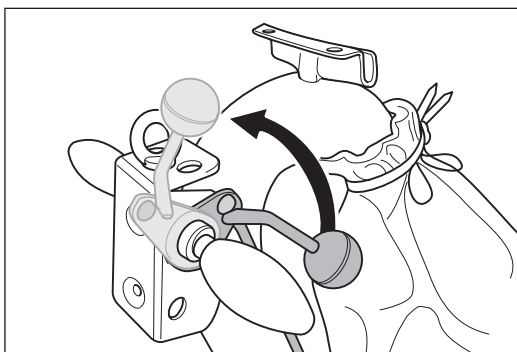

Fig. 30 Lift the sanding drum off the floor by turning the lowering lever at the handle upwards.

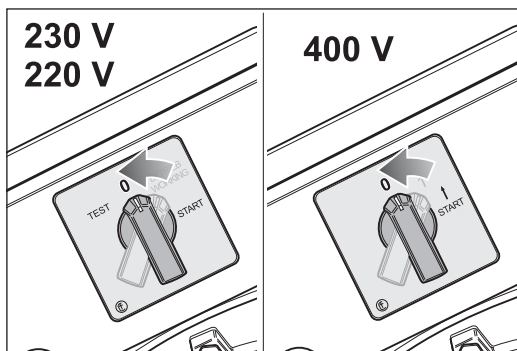

Fig. 31 To switch off the machine turn the switch button to position -0-.

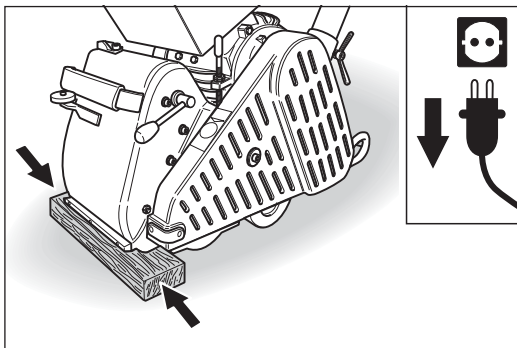

Fig. 32 Secure the machine against sliding!

4.4 SWITCHING OFF THE MACHINE

- 1 Before switch off the machine lift the sanding drum off the floor by turning the lowering lever at the handle upwards (fig. 30).
- 2 Turn the switch button to position -0- (fig. 31).
- 3 **Wait until the sanding drum comes to a standstill!**



CAUTION!

RISK OF INJURY and RISK OF PROPERTY DAMAGE:

- **Always** remove the power plug from the socket after you have switched off the machine!
- **Secure** the machine against sliding! For example, place a flat piece of wood between the floor surface and machine housing (fig. 32).

ATTENTION!

Do not store the unused machine on the sanding drum! Otherwise the sanding media can cause scratches on the ground or the sanding drum can be damaged!

Working with the HUMMEL®

5.1 APPLICATION TIPS

ATTENTION!

- **Always sand from left to right!** This ensures that the left-hand lateral wheel always runs over the newly sanded surface, making the surface more even with each sanding pass and preventing waviness!
- **One sanding track comprises a forward and reverse movement over the same lane without offset!**
- **We advise a sanding track offset of 50%!**

- Deep sanding marks due to the selection of a too coarse grit grade can be prevented by starting the first sanding operation with the finest grit grade possible.
- Carry out a test sanding process using a 50 or 60 grit grade (a few test sanding tracks). If this test is satisfactory and you envisage a good sanding result within a reasonable period, it is more efficient to start the sanding work with these finer grit grade.
- Prevent sanding marks made by previously used grit grade by adhering to the order of the sandpaper grit grade and never skip more than one grit grade.
- Vacuum the floor thoroughly always directly **before each** workstep (every sanding step, gap filling or surface treatment).
- Clean the wheels of the machine before starting each new sanding operation.
- In order to avoid chatter marks, use sanding belts with bud joints and tape.
- After replacing the sanding belt, start working in poorly lit areas of the room in order to remove the initial aggressiveness of the sanding medium.



WARNING!

RISK OF DEATH from electrical shock:

The machine may never be used for wet processing operations of any kind!

NOTE:

For more information free of charge, please

contact: within Germany

- Telephone: 0800 / 52 34 537

- Fax: 0800 / 48 66 353

within the USA

- Telephone: 800-848-6635

or

- Telephone: 0049 - 7135 - 98 90 - 0

- Fax: 0049 - 7135 - 98 90 - 98

- E-mail: info@laegler.com

- Internet: <http://www.laegler.com>

You will also find important and interesting application tips in the LÄGLER® application technique guidelines "Sanding of wooden floors" (<http://www.laegler.com>)!

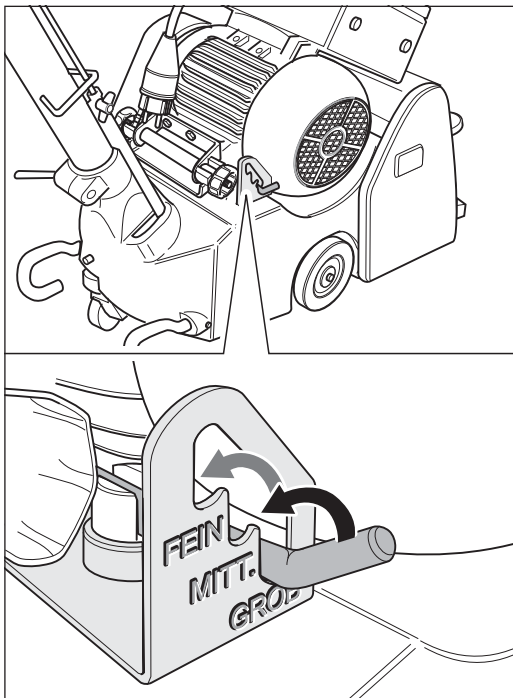

Fig. 33 Different sanding pressure stages can be selected using the setting lever.

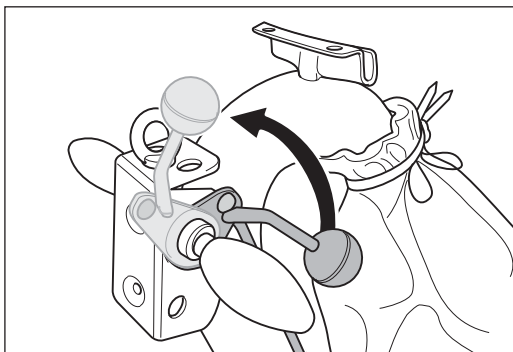

Fig. 34 Lift the sanding drum off the floor by turning the lowering lever at the handle upwards.

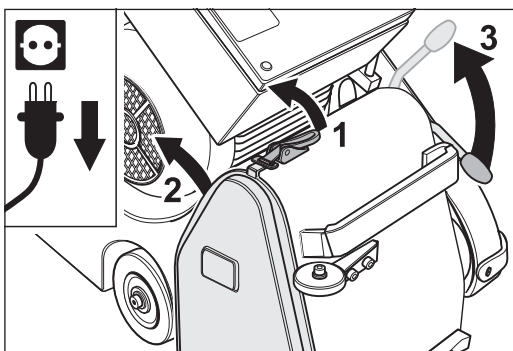

Fig. 35 Release the cover lock (1), remove the side cover (2) and lower the tensioning roller by pulling up the operating lever (3).

5.2 REGULATING THE SANDING DRUM PRESSURE

The lever can be used to set three different drum pressure stages. These three stages - COARSE / MEDIUM / FINE - are designated on the notch plate as -GROB / MITT. / FEIN- (fig. 33).

The pressure stage indications relate to the grit grade sequence. The sanding pressure should be adjusted inline with the grit grade sequence and reduced as the fineness of the grit grade increases. This setting facility permits you to adjust the drum pressure to the prevailing circumstances.

GROB (COARSE) = high sanding pressure for coarse grit grade

MITT. (MEDIUM) = middle sanding pressure for medium grit grade

FEIN (FINE) = low sanding pressure for fine grit grade

In order to avoid dish-outs when sanding soft wood floors, the sanding pressure should be reduced and the sanding speed increased.

5.3 CHANGING THE SANDING BELT

Depending on the type of sanding process you wish to perform, different abrasive grit grades can be selected. In order to change the abrasive, proceed as follows:

- 1 Lift the sanding drum off the floor by turning the lowering lever at the handle upwards (fig. 34).
- 2 **Switch off the machine and pull the power plug out of the socket!**
- 3 Release the cover lock (fig. 35, 1) and remove the side cover on the right of the machine housing (fig. 35, 2).
- 4 To release the tension of the sanding belt, pull the operating lever of the drive unit upwards (fig. 35, 3). This will lower the tensioning roller.

- 5 Remove the worn sanding belt from the tensioning roller and the sanding drum (fig. 36).
- 6 Position the new sanding belt on the tensioning roller of the drive unit (fig. 37) and push it over the tensioning roller and the sanding drum (fig. 38).
- 7 Position the sanding belt so that it evenly covers the sanding drum (fig. 39, A).

**WARNING!**

RISK OF FIRE from the formation of sparks while sanding:

Position B of the sanding belt in fig. 39 provoke sparking during sanding! Avoid this without fail!

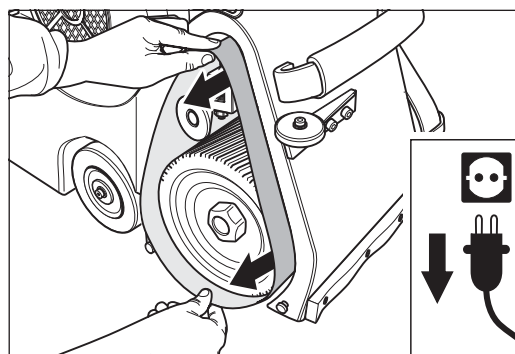

Fig. 36 Remove the sanding belt.

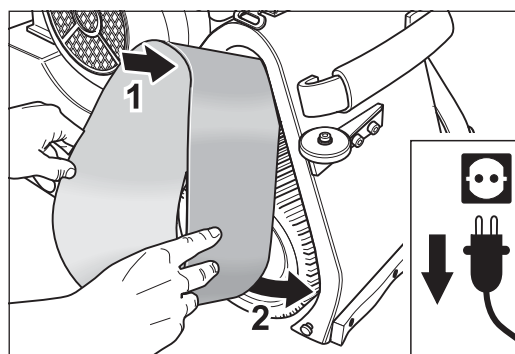

Fig. 37 Position the new sanding belt on the tensioning roller of the drive unit.

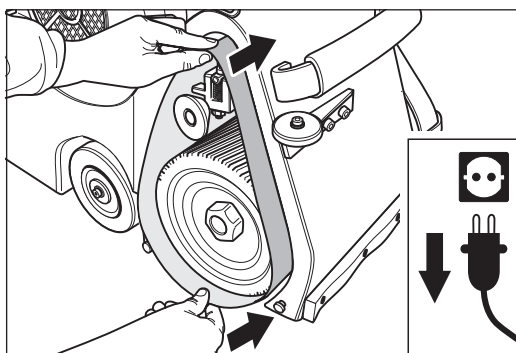

Fig. 38 Push the sanding belt far enough over the sanding drum and tensioning roller so that the sanding drum is fully covered by the sanding belt.

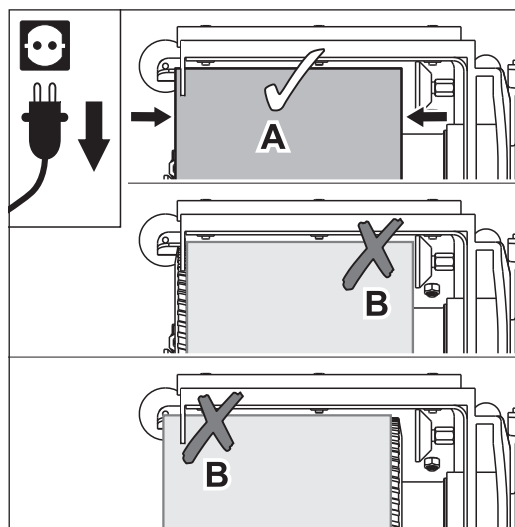

Fig. 39 Position the sanding belt so that it evenly covers the sanding drum (A). Avoid position B without fail (RISK OF FIRE)!

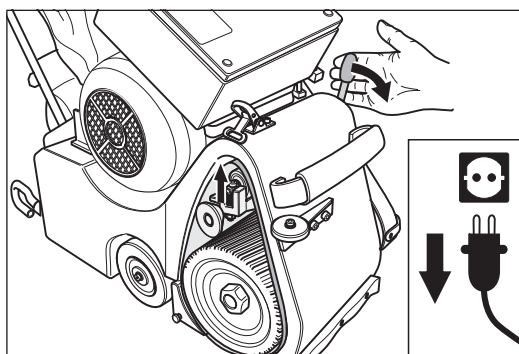

Fig. 40 Tension the sanding belt by lowering the operating lever. **Otherwise, damage or injury can occur!**

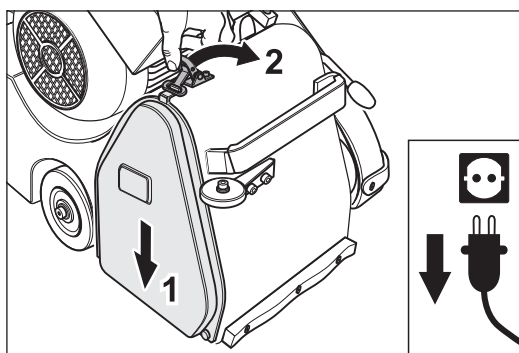

Fig. 41 Mount the side cover.

- 8 To tension the sanding belt, press the operating lever of the drive unit downwards (fig. 40). **Otherwise, damage or injury can occur!**
- 9 Connect the machine to the mains supply (→ *Section 4.2, Connecting the power cable*).
- 10 **Before sanding, the precise tracking of the sanding belt must be checked! Adjusted it if necessary (→ *Section 7.3, Checking and setting the sanding belt tracking*)!**



CAUTION!

RISK OF INJURY and RISK OF PROPERTY DAMAGE from rotating parts of the machine:

- **Always tension the sanding belt before switch on the machine (fig. 40)!**
- **Always lift the sanding drum off the floor before switch on the machine (fig. 34)!**
- **Never reach into the area of the sanding belt while it is running!**
- **During the test run, ensure that no objects randomly positioned in the vicinity can be picked up by the sanding belt and no other persons are in the danger area!**

- 11 After the checking and setting of the sanding belt tracking mount the side cover (fig. 41).
- 12 It is now possible to execute the next sanding process with the machine.

5.4 EMPTYING THE DUST BAG

**WARNING!****RISK OF FIRE from the formation of sparks while sanding:**

- The dust bag must always be removed from the machine directly after sanding and emptied into a non-combustible container outdoors!
Cover this container with a non-combustible cover and be certain to store it and the dust bag outdoors in non-combustible environment!
- Always transport and store used dust bags in closed and non-combustible containers!
- Note the warning on the guide tube (fig. 42)!

HEALTH RISK caused by dust:

In order to ensure that the dust values in the air do not exceed the prescribed threshold levels, please note:

- The dust bag must be emptied when it is one-third full at the very latest in order to prevent a deterioration of the suction performance due to the lack of filtering surface area!
- Do not work with an overfilled dust bag!
- The dust bag must be emptied outdoors!
- When emptying the dust bag, wear a respiratory protective mask (at least filter class P2)!
- Do not wash, patch or repair the dust bag in any other manner!
- Damaged dust bags must be replaced with new ones!

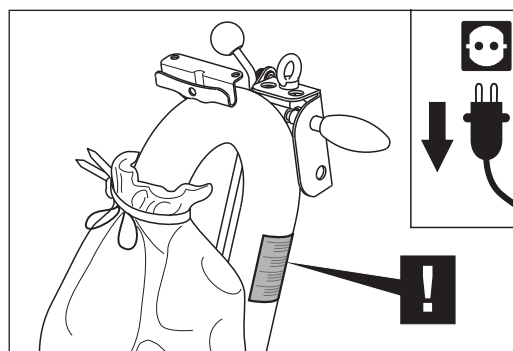

Fig. 42 Note the warning on the guide tube!

Use exclusively original LÄGLER® dust bags for the HUMMEL® (part number in *Section 11, Spare parts HUMMEL®*)!

- 1 Lift the sanding drum off the floor by turning the lowering lever at the handle upwards (fig. 34).
- 2 **Switch off the machine and pull the power plug out of the socket!**
- 3 **Wear the respiratory protective mask (at least filter class P2)!**

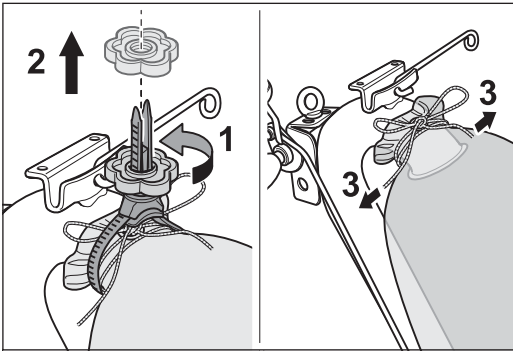

Fig. 43 Remove the MultiClip (1 and 2) and open the cord at the dust bag (3).

- 4 Remove the MultiClip (fig. 43, 1 and 2) and open the cord at the dust bag (fig. 43, 3).
- 5 Take the dust bag away and close it with the cord.
- 6 Empty the dust bag into a **non-combustible** container **outdoors!** Cover this container with a **non-combustible** cover and **be certain** to store it and the dust bag outdoors in **non-combustible** environment (**RISK OF FIRE!**)
- 7 Fasten the empty dust bag firmly using the cord and the MultiClip at the end of the guide tube. Ensuring when mounting that the opening of the guide tube is not closed. **Wear the respiratory protective mask!**

Transport and storage



WARNING!

RISK OF INJURY and RISK OF PROPERTY DAMAGE:

When transported in a car or the like, the machines and all parts must be secured against sliding!

RISK OF FIRE from spontaneous combustion or the formation of sparks while sanding:

- Oil or wax can lead to spontaneous combustion! Therefore, the machine must always be cleaned carefully before transport or storage!
- Always transport and store the machine without dust bag! Store the used dust bag in a closed non-combustible container!

ATTENTION!

- During transport or storage, place a flat piece of wood between the floor surface and machine housing (fig. 44)! This prevents the housing from slipping and stops the drum being in direct contact with the floor!
- During transport or storage, the machine can also be firmly lashed to the bottom part of the supplied transport crate using two belts (fig. 45)! This will prevent damage to the sanding drum and stop the wheels becoming out of round!

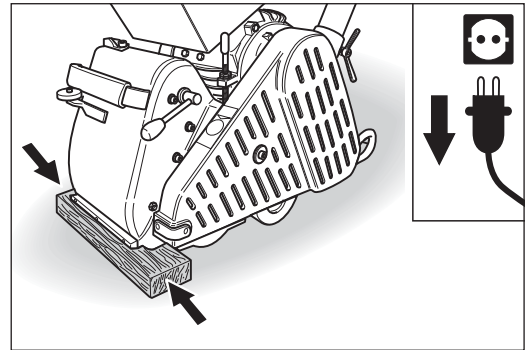

Fig. 44 Transport or storage of the machine on a flat piece of wood.

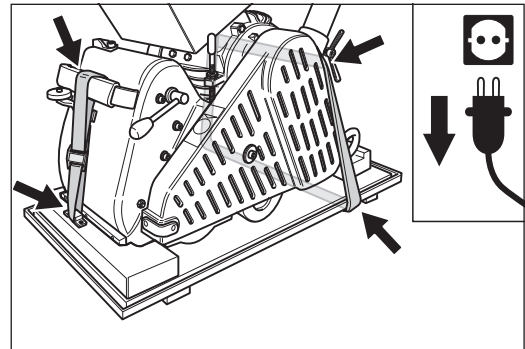

Fig. 45 Transport or storage of the machine on the bottom part of the transport crate.

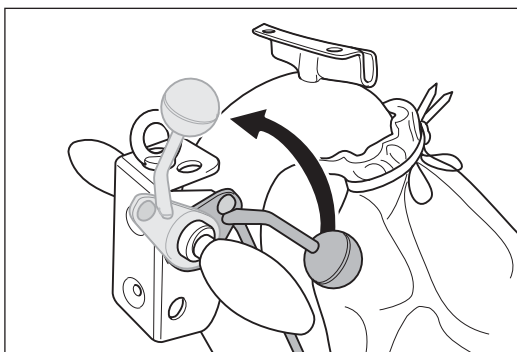

Fig. 46 Lift the sanding drum off the floor by turning the lowering lever at the handle upwards.

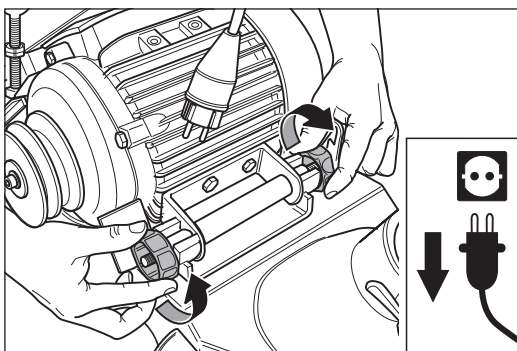

Fig. 47 Loosen the two motor nuts.

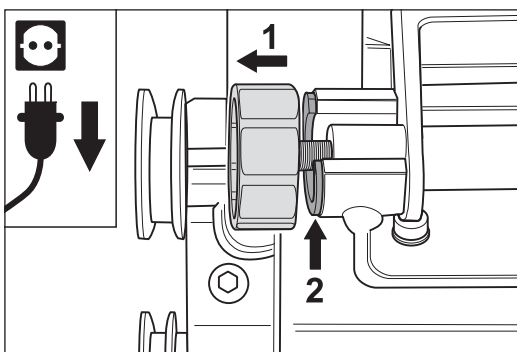

Fig. 48 Turn the two motor nuts out so far (1) until the two nuts used to fit into the motor bearing bracket are exposed (2).

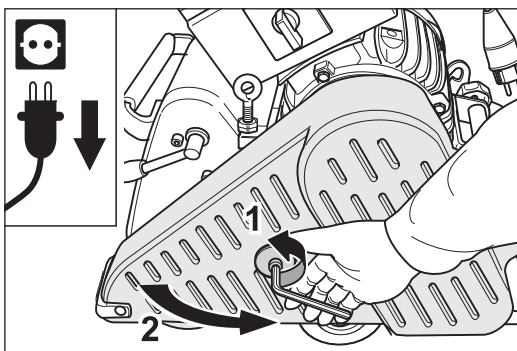

Fig. 49 Pull the power plug out of the socket and open the belt guard.

6.1 DISMANTLING THE MACHINE BEFORE TRANSPORTATION

For transportation, the machine can be dismantled into three parts: Guide tube, motor and machine housing. During manual transport over roads and pavements, to protect the wheels and sanding drum, use the TransCart (part number in *Section 11, Spare parts HUMMEL®*).

- 1 Lift the sanding drum off the floor by turning the lowering lever at the handle upwards (fig. 46).
- 2 **Switch off the machine and pull the power plug out of the socket!**
- 3 Empty the dust bag (→ *Section 5.4, Emptying the dust bag*).
- 4 Loosen the two motor nuts at the motor bearing bracket (fig. 47).
The motor nut must only be backed out from the fitting between the motor nut and motor bearing bracket, and not completely removed (fig. 48).
- 5 Open the belt guard (fig. 49).
- 6 Release the tension of the V-belts by turning the eye bolt at the motor counterclockwise (fig. 50).



CAUTION!

RISK OF INJURY:

During dismantling and mounting the V-belts, take care of your fingers → danger of crushing!

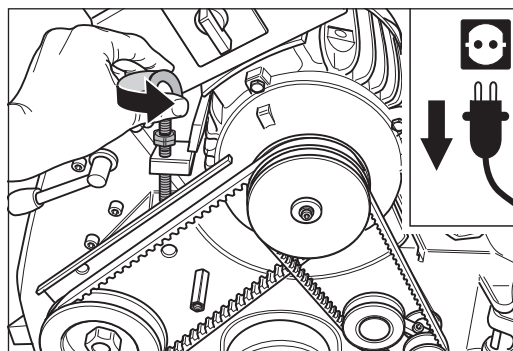

Fig. 50 Release the tension of the V-belts by turning the eye bolt at the motor counterclockwise.

- 7 Turn the motor pulley and allow the suction V-belt to run off the motor pulley (fig. 51).
- 8 Turn the lower pulley and allow the drive V-belt to run off the lower pulley (fig. 52).
If necessary, use the box wrench (see tool kit) to turn the lower pulley **exclusively clockwise!**

ATTENTION!

Only turn the nut with the box wrench at the lower pulley clockwise, as otherwise the nut will work loose (left-hand thread)!

- 9 Remove the motor from the machine housing (fig. 53) and secure it during transport against slipping and damage!
- 10 Press the lowering lever at the handle downwards (fig. 54) to lower the sanding drum onto the floor.

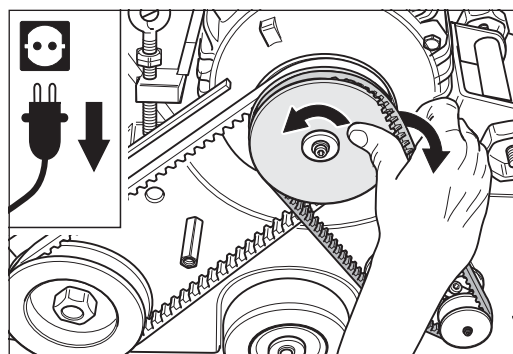

Fig. 51 Remove the suction V-belt.

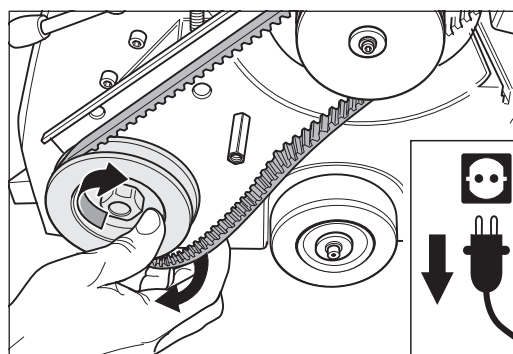

Fig. 52 Allow the drive V-belt to run off the lower pulley. If necessary, use the box wrench (see tool kit) to help you. Turn the pulley **exclusively clockwise** in order not to loosen the nut!

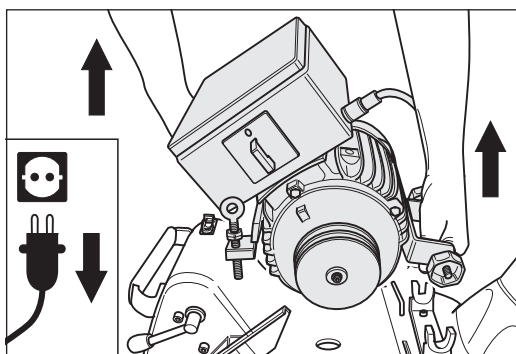

Fig. 53 Remove the motor from the machine housing.

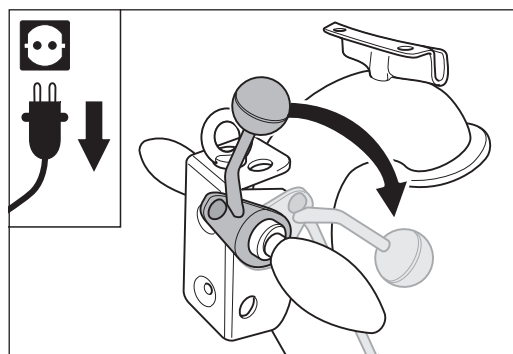

Fig. 54 Press the lowering lever at the handle downwards to lower the sanding drum onto the floor.

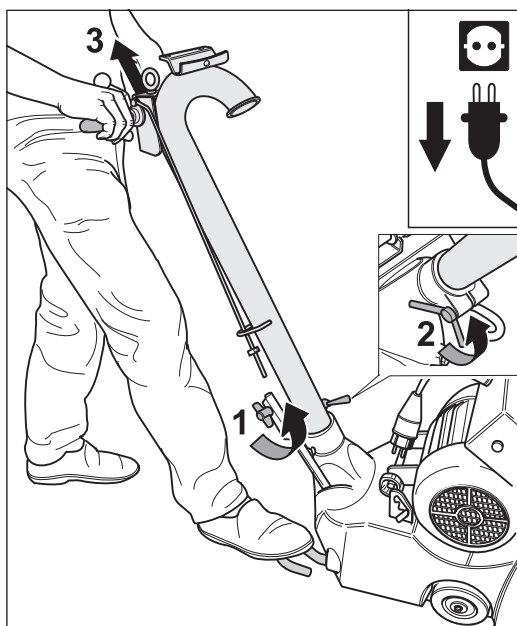

Fig. 55 After opening the wing screw (1) and wing nut (2) which fasten the rod linkage, the guide tube can be drawn out of the machine housing (3).

- 11 Open the wing screw at the lower rod (fig. 55, 1) and the wing nut at the machine housing (fig. 55, 2)
- 12 Pull the guide tube out of the machine housing (fig. 55, 3).

ATTENTION!

Do not tighten the wing nut at the machine housing while the guide tube is removed (fig. 56)! Otherwise the machine housing could break!

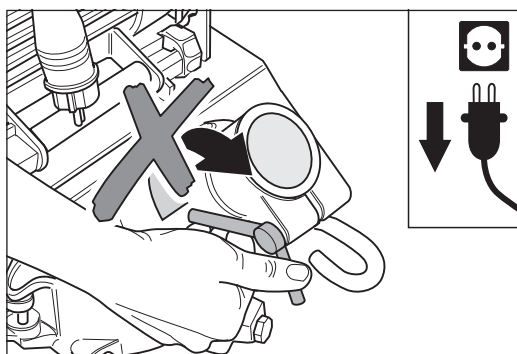

Fig. 56 While the guide tube is removed do **not** tighten the wing nut at the machine housing!

6.2 ASSEMBLY AFTER TRANSPORTATION

When assembling the HUMMEL® after transport, adhere to the following sequence of work steps:

- 1 Press the lowering lever at the handle downwards (fig. 57, 1).
- 2 Insert the guide tube into the opening in the machine housing and at the same time insert the upper rod into the lower rod (fig. 57, 2).
- 3 Carefully tighten the wing screw at the lower rod (fig. 58) and the wing nut at the machine housing (fig. 59).
- 4 Lift the sanding drum off the floor by turning the lowering lever at the handle upwards (fig. 60).
- 5 Place the motor in the motor bearing bracket (fig. 61) and tighten the two motor nuts **slightly** (fig. 62).

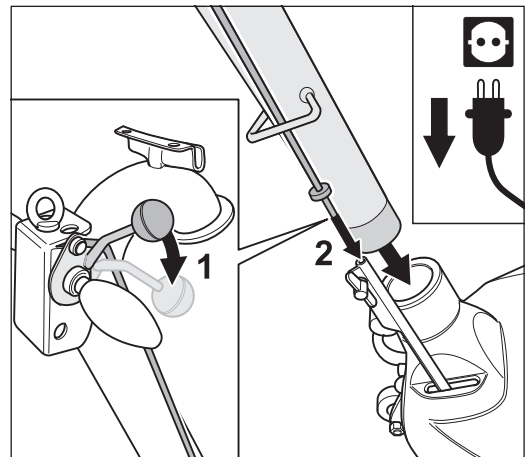

Fig. 57 When inserting the guide tube, make sure that the upper rod of the lowering mechanism feeds in correctly!

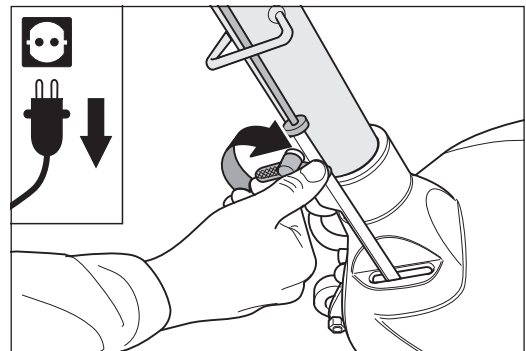

Fig. 58 After inserting the guide tube, carefully tighten the wing screw at the lower rod.

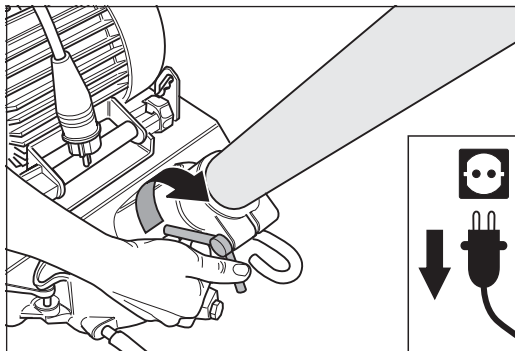

Fig. 59 After inserting the guide tube, carefully tighten the wing nut at the machine housing.

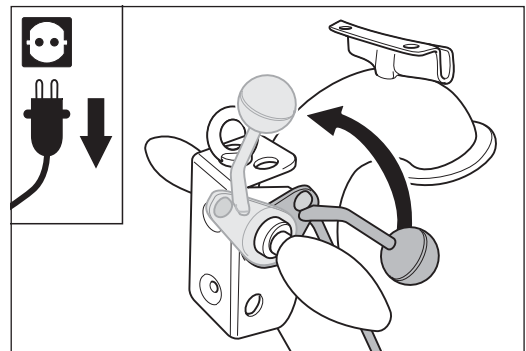

Fig. 60 Lift the sanding drum off the floor by turning the lowering lever at the handle upwards.

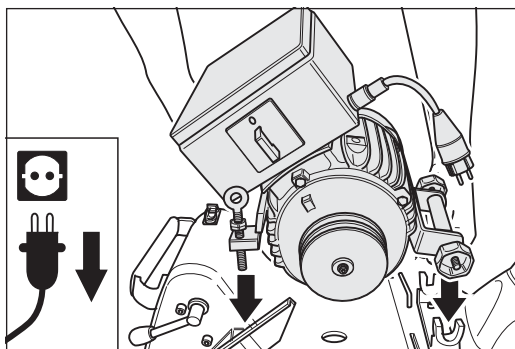

Fig. 61 Place the motor in the motor bearing bracket.

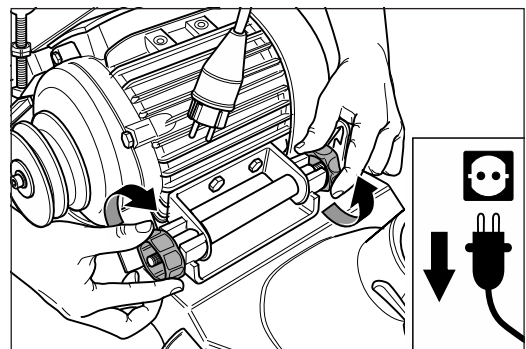

Fig. 62 Tighten the two motor nuts.

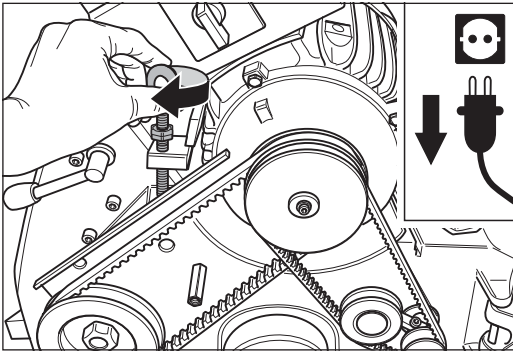

Fig. 63 Mount the V-belts and tension them by turning the eye bolt at the motor clockwise.

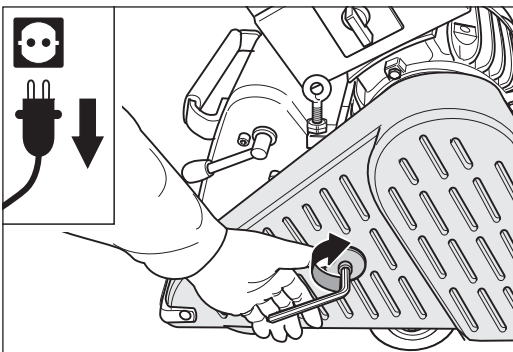

Fig. 64 Close the belt guard.

- 6 Mount the V-belts and tension them by turning the eye bolt at the motor clockwise (fig. 63).
- 7 Tighten the two motor nuts (fig. 62).
- 8 Close the belt guard (fig. 64).
- 9 Mount the dust bag at the guide tube (→ *Section 4.1, Preparing the machine for operation*).
- 10 Connect the machine to the mains supply (→ *Section 4.2, Connecting the power cable*).
- 11 The machine is now ready for use.

6.3 STORAGE



WARNING!

RISK OF FIRE from the formation of sparks while sanding:

- **Always transport and store the machine without dust bag!**
- **Store the emptied dust bag in a closed non-combustible container!**

If you wish to keep the machine in storage for a protracted period, ensure that it is kept dry and free of the influence of frost in a location without excessive temperature fluctuations.

Store your unused machine in a dry, closed location out of the reach of children!

ATTENTION!

When storing for long periods, place the machine on the bottom part of the supplied transport crate (fig. 45)! This will prevent damage to the sanding drum and stop the wheels becoming out of round!

Maintenance work and replacement of wearing parts



WARNING!

RISK OF DEATH from electrical shock and RISK OF INJURY from rotating parts of the machine:

- **All extensive maintenance work, especially on the electrical equipment, must be conducted by a qualified expert for safety reasons!**
- **All maintenance work must be conducted with the machine switched off and with the power plug removed from the socket!**

ATTENTION!

- **Only use original spare parts from LÄGLER®! This is the only way to ensure that your machine continues to perform! Warranty claims for foreign parts or damage caused thereby cannot be accepted!**
- **Never conduct a maintenance or a replacement of wearing parts on the newly sanded wooden floor! Thus, you will avoid scratches or other damage to the floor!**
- **Never use any cleaning products which contain solvents!**

Periodically but at the latest when you notice that damage has occurred, a variety of maintenance procedures have to be performed. For this work, use exclusively original spare parts from LÄGLER®.

Work in a clean, well lit location and proceed in accordance with these operating instructions. In the tool kit, you will find all the tools required to carry out the work described below.

It takes only a minimal amount of time to inspect the machine, but this precautionary measure can save subsequent complaints brought about by minor damage to the machine. Performing regular maintenance work will help to retain the value of the machine and is also in the interests of your own safety.

7.1 CLEANING AND CARE INSTRUCTIONS

**WARNING!****RISK OF FIRE from spontaneous combustion and the formation of sparks while sanding:**

- **There is a high risk of fire when sanding woods with a large amount of resin, oiled or waxed floors or metal! Therefore, the machine must always be cleaned carefully directly after sanding!**
- **Be certain to note the warning notices of the manufacturers of the paint, oil and wax!**

7.1.1 GENERAL

Before starting work, you should perform the following care procedure in order to ensure that the machine is in full working order and produces the customary high-quality sanding finish:

- Check the tensioning roller and the sanding drum for damage. Clean the parts carefully and ensure that the rubber coating on the rollers is not damaged!
- Check the sanding belt tracking and adjust it if necessary using a grit grade 120 sanding belt (➔ *Section 7.3, Checking and setting the sanding belt tracking*).
- Check if the guide rollers at the drive unit and inside the machine housing are rotatable easily!
Guide rollers which are not rotatable easily provoke sparking during sanding and must be replaced without fail (part number in *Section 11, Spare parts HUMMEL®*)!
- Clean the wheels of the machine.
- Check the tension of the V-belts and correct it if necessary with the aid of the eye bolt at the motor (➔ *Section 7.10, Replacement and tensioning of V-belts*).
- Check that the lowering rod linkage is easy running.
- Check the dust suction system and the dust bag for leaks and damages.

- Carry out a visual inspection of the electrical equipment (extension cable, plug, couplings).

7.1.2 DISMANTLING AND CLEANING OF DRIVE UNIT

The drive unit should be removed and cleaned at least once a week if the machine is used every day.

ATTENTION!

**A dirty drive unit avoids an ideal sanding belt adjustment!
This cause negative effects to the sanding result!**

The drive unit is removed using the following procedure:

- 1 Lift the sanding drum off the floor by turning the lowering lever at the handle upwards (fig. 65).
- 2 **Switch off the machine and pull the power plug out of the socket!**
- 3 Release the cover lock (fig. 66, 1) and remove the side cover on the right of the machine housing (fig. 66, 2).
- 4 Pull the operating lever of the drive unit upwards (fig. 66, 3). This will lower the tensioning roller.
- 5 Remove the sanding belt from the tensioning roller and the sanding drum (fig. 67).
- 6 If you wish to remove the tensioning roller of the drive unit (→ *Section 7.7, Replacement of tensioning roller*), press the operating lever of the drive unit downwards (fig. 68).
- 7 Remove the operating lever of the drive unit by unscrewing (fig. 69).

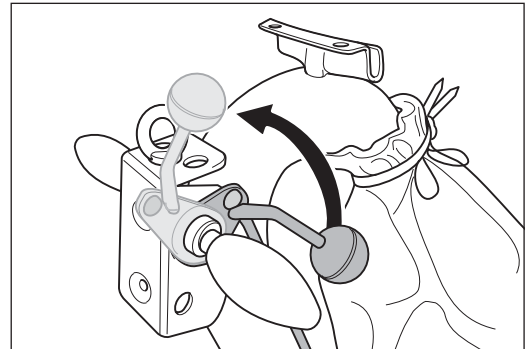

Fig. 65 Lift the sanding drum off the floor by turning the lowering lever at the handle upwards.

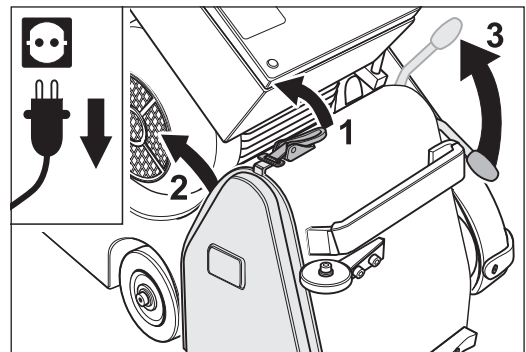

Fig. 66 Release the cover lock (1), remove the side cover (2) and lower the tensioning roller by pulling up the operating lever (3).

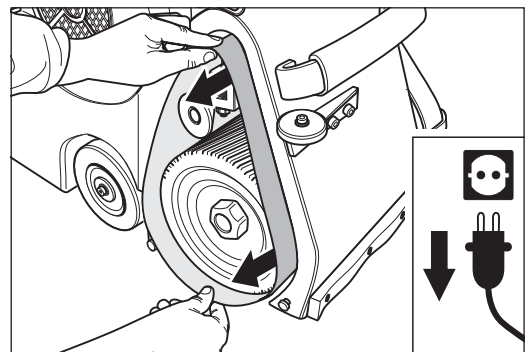

Fig. 67 Remove the sanding belt.

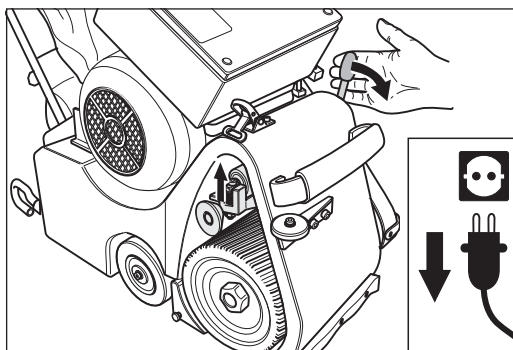

Fig. 68 Press the operating lever of the drive unit downwards.

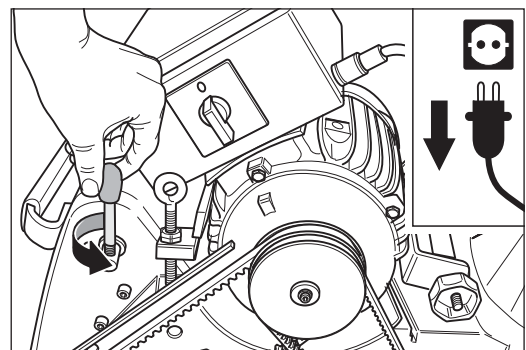

Fig. 69 Unscrew the operating lever of the drive unit.

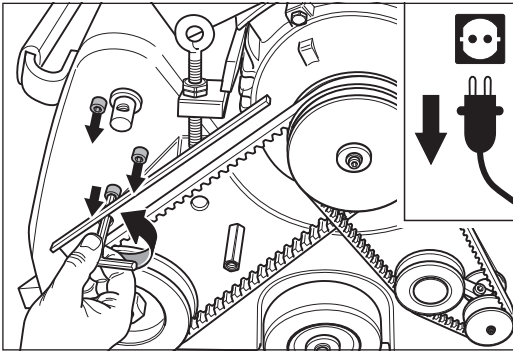

Fig. 70 Hold on the drive unit and remove the three screws **at the same time**.

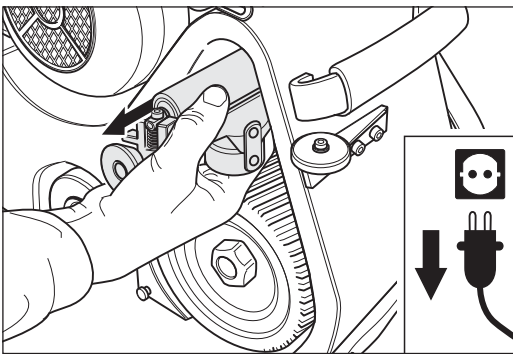

Fig. 71 Carefully remove the drive unit.

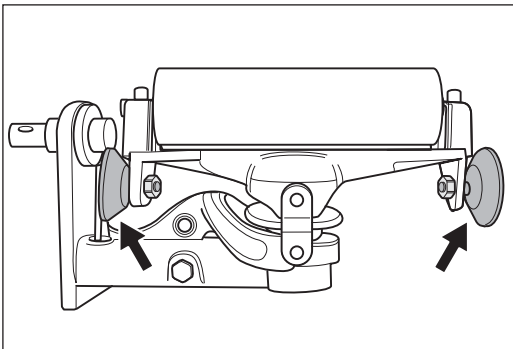

Fig. 72 The two guide rollers at the drive unit **must be rotatable easily!** Otherwise they **must be replaced (RISK OF FIRE)!**

8 Hold on the drive unit and remove the three screws **at the same time** (fig. 70)! Therefore the drive unit cannot fall on the sanding drum.

9 Carefully remove the drive unit (fig. 71) and clean it. **Never use any cleaning products which contain solvents!**



WARNING!

RISK OF FIRE from the formation of sparks while sanding:

- The two guide rollers at the drive unit **must** be rotatable easily (fig. 72)!
- Guide rollers which are not rotatable easily provoke sparking during sanding and **must** be replaced without fail (part number in *Section 11, Spare parts HUMMEL®!*)

10 Reassemble in reverse order.

11 **After mounting the drive unit, check the precise tracking of the sanding belt and adjust it if necessary (→ Section 7.3, Checking and setting the sanding belt tracking)!**

Regular exchange of the sanding drum and tensioning roller guarantees a constant degree of operating quality and performance. When working every day with the machine, they must be exchanged every 1 – 2 years, otherwise every 3 – 4 years (→ Section 7.6, Replacement of sanding drum and Section 7.7, Replacement of tensioning roller).

7.2 LUBRICATION

Machines up to year of manufacture 1997:

For general upkeep of the machine, after around 100 operating hours we recommend sparing lubrication of the two lubrication nipples at the wheel bearings using a manual grease gun (tool kit) using ball bearing grease.

ATTENTION!

In machines from year of manufacture 1998, the lubrication points at the wheel bearing has been replaced by a self-lubricating plastic bushing. This bushing does not require lubrication! Never use sprays such as WD 40 or similar!

In order to guarantee lasting easy running of the moving parts, lubricate at regular intervals at the following lubrication points (fig. 73):

A Top part of the rod linkage at the lever plate

B Lever plate on the handle shaft

To do this, tilt the machine slightly to one side and allow a small amount of oil to run into the lubrication points.

C Wing screw on the bottom part of the rod linkage

D Guide tube in the machine housing

E Wing nut at the machine housing

Use customary lubricating oil for these lubrication points - never use grease or sprays such as WD 40 or similar!

7.3 CHECKING AND SETTING THE SANDING BELT TRACKING

The sanding belt tracking must be checked every time the sanding belt is exchanged, but at least once a day!



CAUTION!

RISK OF INJURY and RISK OF PROPERTY DAMAGE:

During the test run, the sanding drum must be raised off the floor (fig. 74)!

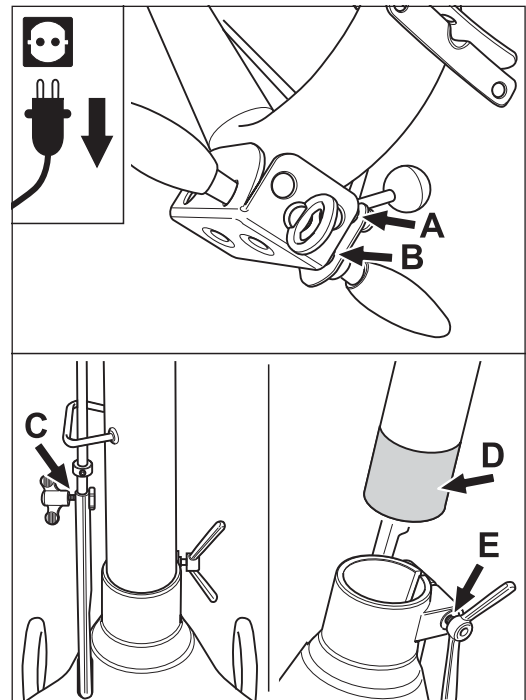

Fig. 73 Lubrication points which should be regularly oiled.

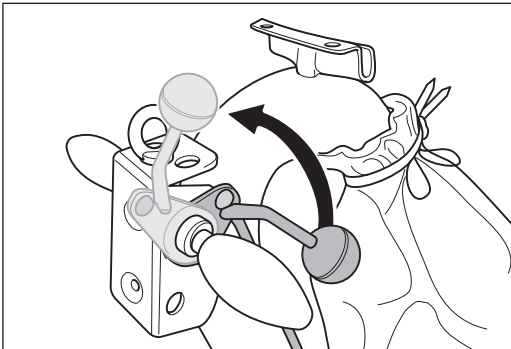

Fig. 74 Lift the sanding drum off the floor by turning the lowering lever at the handle upwards

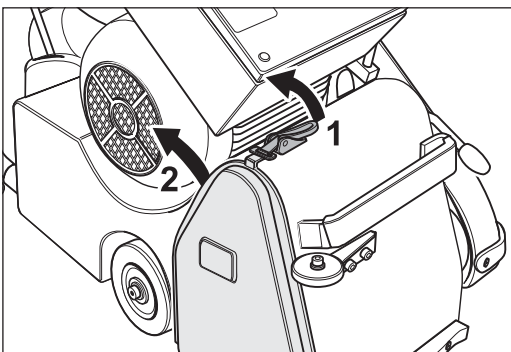

Fig. 75 Release the cover lock (1) and remove the side cover (2).

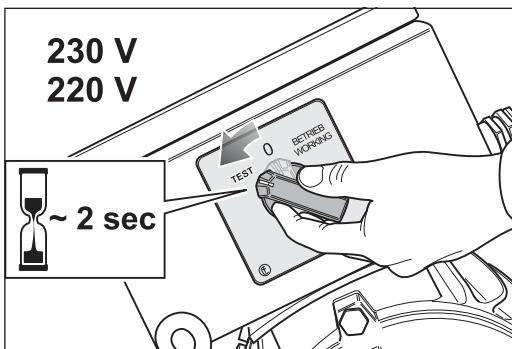

Fig. 76 **Single-phase AC motor:**
Hold the switch button for around 2 seconds in -TEST- position and control the sanding belt tracking **at the same time**. After this release the switch button.

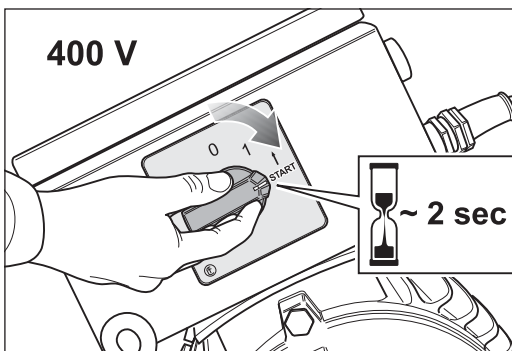

Fig. 77 **Three-phase AC motor:**
Hold the switch button for around 2 seconds in -START- position and control the sanding belt tracking **at the same time**. After this turn the switch button in position -0-.

7.3.1 CHECKING THE SANDING BELT TRACKING

- 1 **Lift the sanding drum off the floor by turning the lowering lever at the handle upwards (fig. 74)!**
- 2 **Switch off the machine!**
- 3 Release the cover lock (fig. 75, 1) and remove the side cover on the right of the machine housing (fig. 75, 2).



CAUTION!

RISK OF INJURY and RISK OF PROPERTY DAMAGE from rotating parts of the machine:

- **Never reach into the area of the sanding belt while it is running!**
- **During the test run, ensure that no objects randomly positioned in the vicinity can be picked up by the sanding belt and no other persons are in the danger area!**

- 4 Machines with **single-phase** AC motor (mains voltage **230 V** and **220 V**):
Turn the switch button in position -TEST- and hold the switch button for around 2 seconds in this position (fig. 76). **At the same time** control the sanding belt tracking. After this release the switch button.

Machines with **three-phase** AC motor (mains voltage **400 V**):

Turn the switch button in position -START- and hold the switch button for around 2 seconds in this position (fig. 77). **At the same time** control the sanding belt tracking. After this turn the switch button to position -0-.

- 5 If the sanding belt runs to the front (towards **A** in fig. 78) or to the back (towards **B** in fig. 78) the setting of the sanding belt regulation is necessary (→ *Section 7.3.2, Setting the sanding belt tracking*). If the sanding belt tracking is alright, mount the side cover (fig. 79).

7.3.2 SETTING THE SANDING BELT TRACKING

Should the setting of the sanding belt tracking be necessary, proceed as follows:

- 1 **Lift the sanding drum off the floor by turning the lowering lever at the handle upwards (fig. 74)!**
- 2 **Switch off the machine!**
- 3 Release the cover lock (fig. 75, 1) and remove the side cover on the right of the machine housing (fig. 75, 2).
- 4 Check whether any soiling at the tensioning roller calls for readjustment. If so, the tensioning roller must be cleaned (→ Section 7.1.2, *Dismantling and cleaning of drive unit*) and the sanding belt tracking must be checked again (→ Section 7.3.1, *Checking the sanding belt tracking*).
- 5 Always set the sanding belt tracking using a sanding belt with as fine a grit grade as possible (= flexible sanding belt). This is because the more flexible the sanding belt, the precisely it is possible to set the tensioning roller.

Mount the sanding belt (→ Section 5.3, *Changing the sanding belt*) and carry out a test run (→ Section 7.3.1, *Checking the sanding belt tracking*).

If the sanding belt is running out of true (in direction of **A** or **B** in fig. 78), it must be turned around and another test performed.

If the sanding belt runs to the front (in direction of **A** in fig. 78) and after turning over runs to the back (in direction of **B** in fig. 78) or vice versa, the sanding belt is of poor quality and is **not usable** (conical sleeve)!

If the sanding belt runs in the same direction both times, the tensioning roller requires readjustment.

- 6 If readjustment of the tensioning roller is necessary, release the lock nut at the drive unit (fig. 80, 1) and adjust the tensioning roller with the screw (fig. 80, 2):

A Rotation **clockwise**:
sanding belt runs **to the front**

B Rotation **counterclockwise**:
sanding belt runs **to the back**

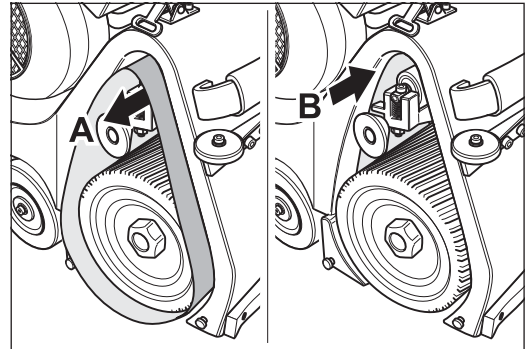

Fig. 78 If the sanding belt runs in direction of **A** or **B**, the setting of the sanding belt regulation is necessary.

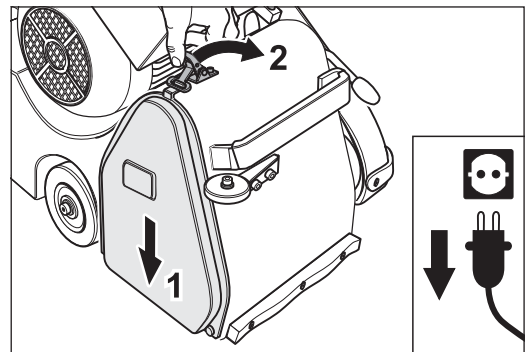

Fig. 79 Mount the side cover.

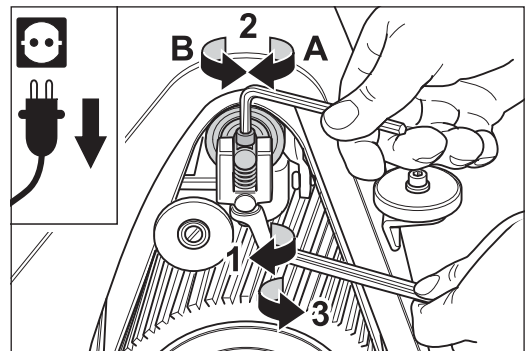

Fig. 80 Adjust the sanding belt tracking at the setting screw of the drive unit (see description on the right).

- 7 If the sanding belt tracking is seen to be correct after adjusting once, tighten the lock nut again (fig. 80, 3).

**CAUTION!**

RISK OF INJURY and RISK OF PROPERTY DAMAGE from rotating parts of the machine:

If the lock nut at the upper part of the drive unit is not tightened, it will loosen during operation of the machine and falls on rotating parts!

ATTENTION!

If the lock nut at the upper part of the drive unit is not tightened, the tensioning roller can move out of place! This cause negative effects to the sanding result!

- 8 If the sanding belt tracking is seen to be not correct after adjusting once, repeat the process.
- 9 After successful setting of the sanding belt tracking mount the side cover (fig. 79).

7.4 CHECKING THE MACHINE SETTING

ATTENTION!

The best working result is achieved when the sanding drum sands centrally! Only with this setting is it possible to avoid the belt from sanding too deep on one side, resulting in unwanted sanding marks!

From time to time, or as a result of incorrect transportation, it is possible for the machine to become incorrectly adjusted. Incorrect adjustment is indicated by one-sided sanding of the sanding drum, which can lead to sanding tracks and complaints. Correction of machine setting is performed as follows:

- 1 Lift the sanding drum off the floor by turning the lowering lever at the handle upwards (fig. 74).

- 2 **Switch off the machine and pull the power plug out of the socket!**
- 3 Tilt the machine backwards over the safety guards so that you can see the wheel bearings (fig. 81). **Ensure that the machine is standing securely!**
- 4 The wheel on the belt guard side can be adjusted by releasing the tension screw. The other wheel is firmly fixed using a screw.
- 5 For setting, first take the actual position of the adjustable wheel using the setting fixture (right-hand wheel seen from below). Position the fixture against the machine housing in such a way that it rests not only against the machine housing on both sides, but also at the adjustable wheel. If necessary, turn the threaded pin of the setting device. To do this, release the nut of the setting fixture (fig. 82).
- 6 If the machine is **sanding more heavily on the belt guard side (A in fig. 83)**, the **wheel must be adjusted away from the belt guard (direction of B in fig. 83)**.

If the machine is **sanding more heavily on the side cover side (C in fig. 83)**, the **wheel must be adjusted towards the belt guard (direction of D in fig. 83)**.

Now adjust the threaded pin of the setting device in the relevant direction by the required amount.

- 7 Release the clamping screw at the wheel clamp of the adjustable wheel (fig. 84) and place the setting fixture against the machine housing again.
- 8 Set the wheel in the required position by means of the setting fixture so that the wheel lining just still makes contact with the threaded pin when turning, and tighten the clamping screw again.
- 9 Carry out a sanding test to check whether the machine is now correctly adjusted. If not, the process will have to be repeated.

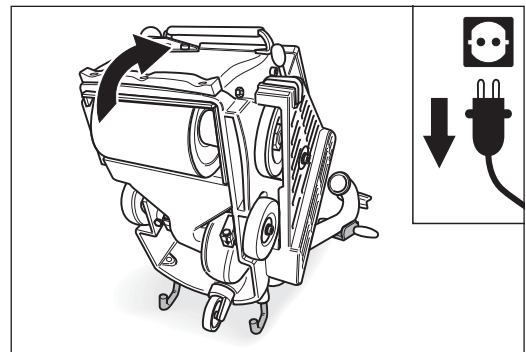

Fig. 81 **Pull the power plug out of the socket!** Tilt the machine backwards. **Ensure that the machine is standing securely!**

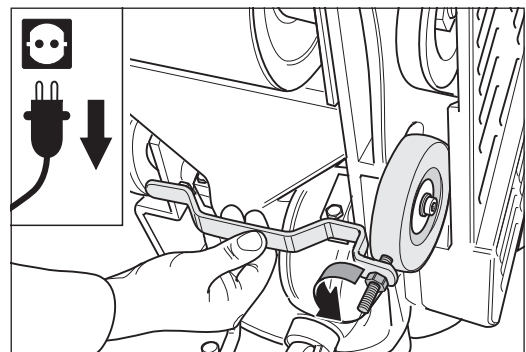

Fig. 82 Take the actual position of the adjustable wheel using the setting fixture (right-hand wheel seen from below).

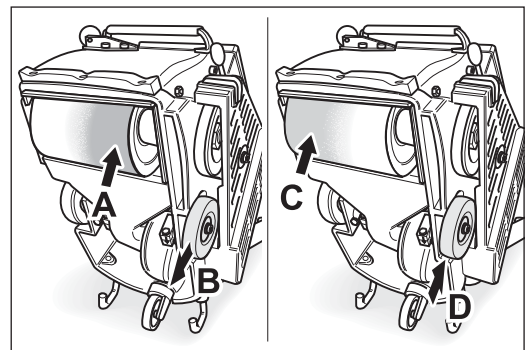

Fig. 83 If the machine is sanding more on side **A**, the wheel must be adjusted in the direction of **B**. If the machine is sanding more on side **C**, the wheel must be adjusted in the direction of **D**.

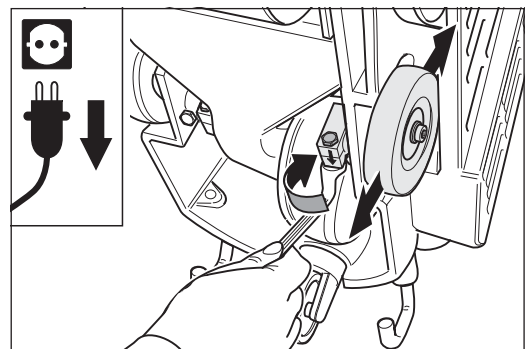

Fig. 84 Release the screw on the right-hand wheel clamp.

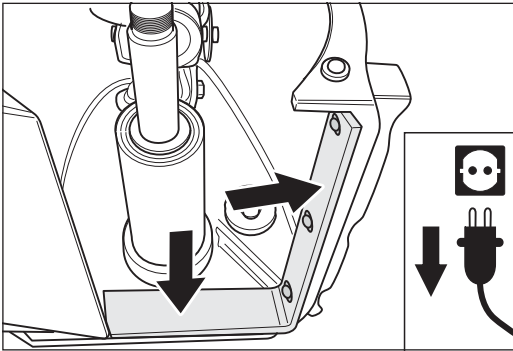

Fig. 85 The sealing felt must not demonstrate any signs of damage, otherwise replace!

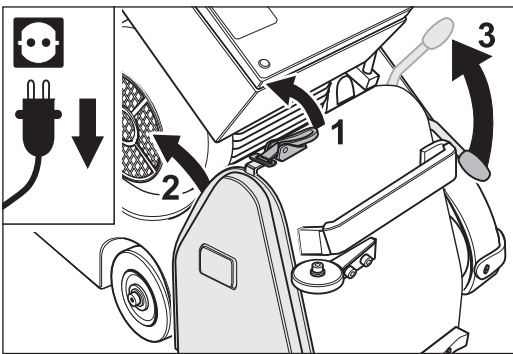

Fig. 86 Release the cover lock (1), remove the side cover (2) and lower the tensioning roller by pulling up the operating lever (3).

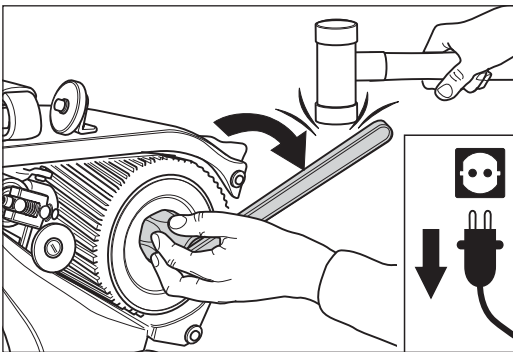

Fig. 87 Release the drum nut **clockwise (left-hand thread)**, if necessary by knocking gently with a soft hammer.
Never use a steel hammer!

7.5 CHECKING THE DUST PICK-UP

In order to guarantee optimum dust pick-up for your safety and that of others, the following points must be observed:

- Always used original LÄGLER® dust bags (part number in *Section 11, Spare parts HUMMEL®*)!
- Never use damaged, washed, patched or in any other way repaired dust bags!
- Ensure that the sealing felt is not worn or damaged (fig. 85)!
- Check the suction system for blockages or deposits!

7.6 REPLACEMENT OF SANDING DRUM

Use exclusively original LÄGLER® sanding drums (part number in *Section 11, Spare parts HUMMEL®*)!

- 1 Lift the sanding drum off the floor by turning the lowering lever at the handle upwards (fig. 74).
- 2 **Switch off the machine and pull the power plug out of the socket!**
- 3 Release the cover lock (fig. 86, 1) and remove the side cover on the right of the machine housing (fig. 86, 2).
- 4 Pull the operating lever of the drive unit upwards (fig. 86, 3). This will lower the tensioning roller.
- 5 Remove the sanding belt from the tensioning roller and the sanding drum.
- 6 Tilt the machine backwards over the safety guards (fig. 81).
Ensure that the machine is standing securely!
- 7 Open the drum nut by turning the box wrench (see tool kit) **clockwise (left-hand thread)** and unscrew the drum nut (fig. 87)!
If necessary, take a soft hammer to help you loosen the nut.
Never use a steel hammer!

- 8 Turn the sanding drum in such a way that the groove is pointing upwards to ensure that the parallel key is not lost (fig. 88). Now pull the sanding drum out sideways out of the housing.

If the sanding drum is too stiff to move, use a lath (fig. 89) to dislodge it, so as not to damage the machine! Never attempt to loosen the sanding drum by hitting with a hammer!

- 9 Clean the shaft stump and oil it slightly.
- 10 Push on the new sanding drum. **Pay attention to the parallel key!**
- 11 Perform the remaining assembly steps in reverse order.

7.7 REPLACEMENT OF TENSIONING ROLLER

Use exclusively original LÄGLER® tensioning rollers (part number in *Section 11, Spare parts HUMMEL®*)!

- 1 Remove the drive unit (→ *Section 7.1.2, Dismantling and cleaning of drive unit*).
- 2 Clamp the drive unit in a vise. If you are unable to reach the lock nuts with the closed-mouth wrench, screw the lever into the crank again and turn it downwards (fig. 90, 1) so that the top of the drive unit is lifted up.
- 3 Remove the two fixing screws in the tensioning roller while holding onto the locknuts with a closed-mouth wrench (fig. 90, 2).
- 4 Remove the tensioning roller and check the compression spring. Should this be deformed, the compression spring (part number in *Section 11, Spare parts HUMMEL®*) must be renewed.
- 5 Clean the drive unit. **Do not use any cleaning products which contain solvents!**
- 6 Insert the compression spring and the tensioning roller. Ensure that the surfaces on the shaft ends of the tensioning roller are pointing upwards (fig. 91)!

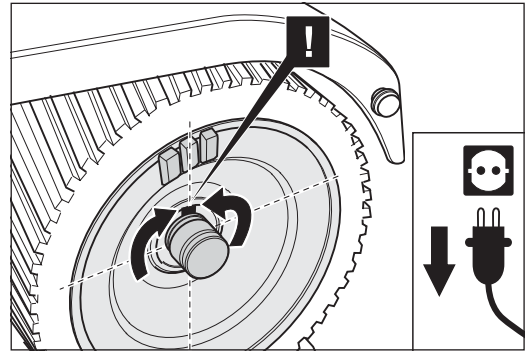

Fig. 88 Turn the sanding drum in such a way that the groove is pointing upwards to ensure that the parallel key is not lost.

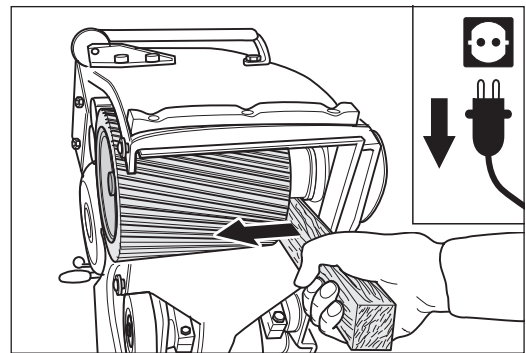

Fig. 89 If the sanding drum is too stiff to be removed, carefully lever it away with a lath. **Never use brute force!**

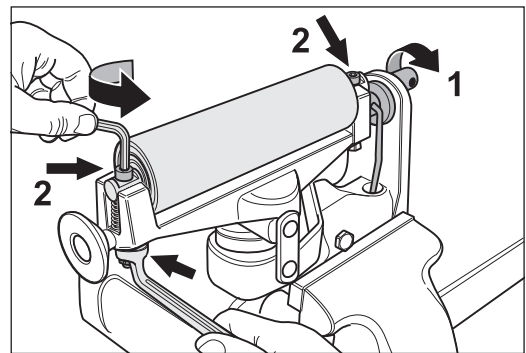

Fig. 90 Turn the crank in the indicated direction (1). Remove the two fixing screws in the tensioning roller while holding onto the locknuts with a closed mouth wrench (2).

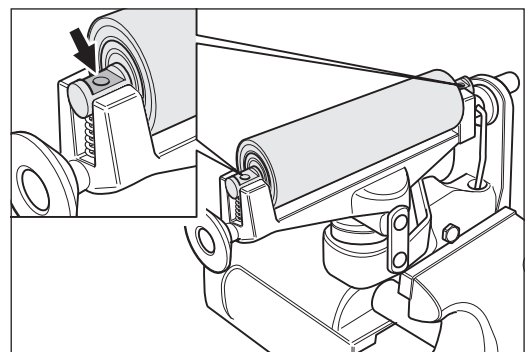

Fig. 91 Insert the new tensioning roller, ensuring that the surfaces on the shaft ends are pointing upwards!

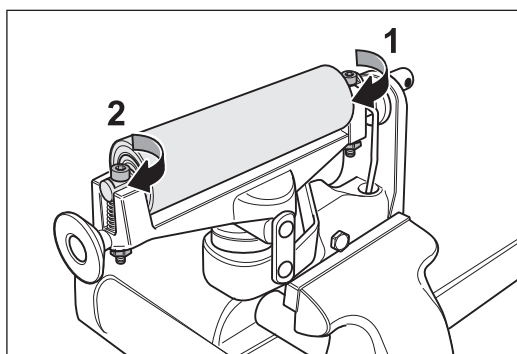

Fig. 92 Tighten the side without spring (1) and then the side with spring (2), so that ...

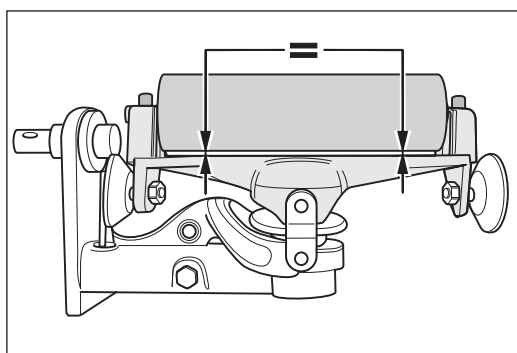

Fig. 93 ... the tensioning roller is positioned parallel to the top of the drive unit.

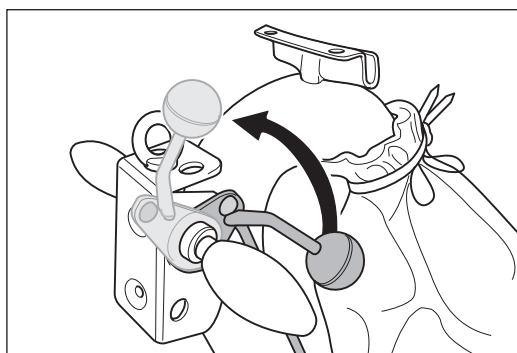

Fig. 94 Lift the sanding drum off the floor by turning the lowering lever at the handle upwards

- 7 Tighten the screw of the unsprung bearing pedestal side (fig. 92, 1).
- 8 Turn the screw on the sprung side of the tensioning roller (fig. 92, 2) far enough so that the tensioning roller is positioned parallel to the upper part of the drive unit (fig. 93).
- 9 **Tighten the lock nuts of the fixing screws!**



CAUTION!

RISK OF INJURY and RISK OF PROPERTY DAMAGE from rotating parts of the machine:

If the lock nuts of the fixing screws are not tightened, they will loosen during operation of the machine and fall on rotating parts!

ATTENTION!

If the lock nuts of the fixing screws are not tightened, the tensioning roller can move out of place! This cause negative effects to the sanding result!

- 10 Remount the drive unit (→ *Section 7.1.2, Dismantling and cleaning of drive unit*).
- 11 Check the sanding belt tracking (→ *Section 7.3.1, Checking the sanding belt tracking*).

7.8 REPLACEMENT OF REAR WHEEL

Use exclusively original LÄGLER® rear wheels (part number in *Section 11, Spare parts HUMMEL®!*)

7.8.1 REPLACEMENT OF REAR WHEEL ONLY

- 1 Lift the sanding drum off the floor by turning the lowering lever at the handle upwards (fig. 94).
- 2 **Switch off the machine and pull the power plug out of the socket!**

- 3 Tilt the machine forward over the bracket (fig. 95). **Ensure that the machine is standing securely (fig. 96)!**
- 4 Release the screw in the center of the wheel and remove the screw, washers and nut (fig. 97). Ensure that you do not lose the nut.
- 5 Pull the back wheel off the tail axle housing.
- 6 Push the new back wheel onto the tail axle housing.
- 7 Insert the nut in the hexagonal recess of the tail housing and hold onto the nut. Mount the washers and the screw.

7.8.2 REPLACEMENT OF COMPLETE REAR WHEEL ASSEMBLY

- 1 Lift the sanding drum off the floor by turning the lowering lever at the handle upwards (fig. 94).
- 2 **Switch off the machine and pull the power plug out of the socket!**
- 3 Tilt the machine forward over the bracket (fig. 95). **Ensure that the machine is standing securely (fig. 96)!**
- 4 Release the screw which fastens the tail axle of the rear wheel in the machine housing (fig. 98).
- 5 Pull the complete rear wheel assembly out of the machine housing (fig. 98).
- 6 Mount the complete new back wheel in reverse sequence and fasten it again in the machine housing, aligning the clamping surface of the tail axle towards the screw (fig. 98).

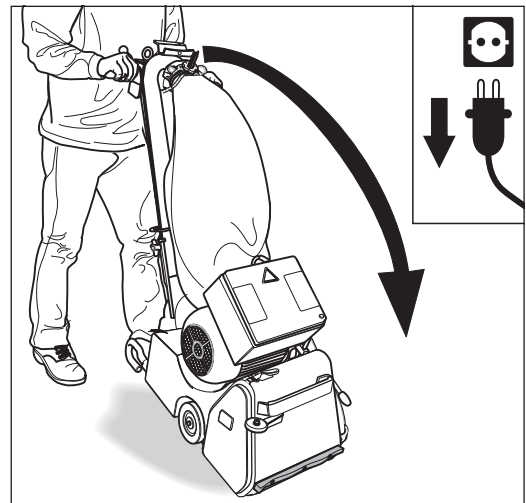

Fig. 95 **Pull the power plug out of the socket!** Tilt the machine forward over the bracket.

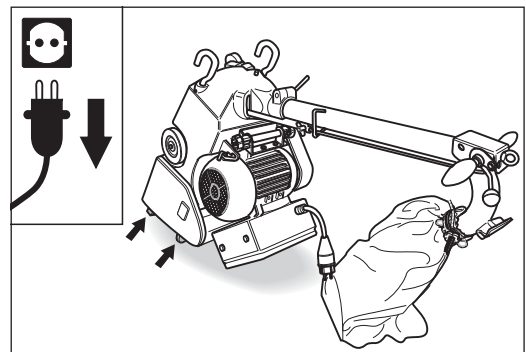

Fig. 96 **Ensure that the machine is standing securely!**

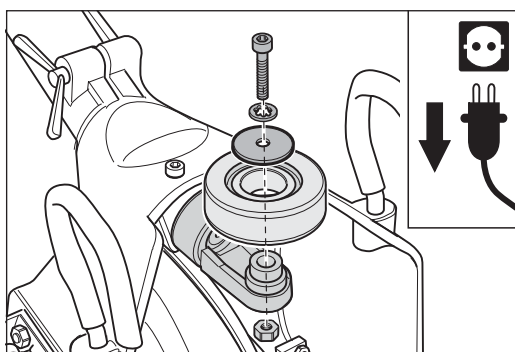

Fig. 97 Remove the screw with the washers and nut in the center of the wheel and take off the back wheel. Assemble in reverse sequence.

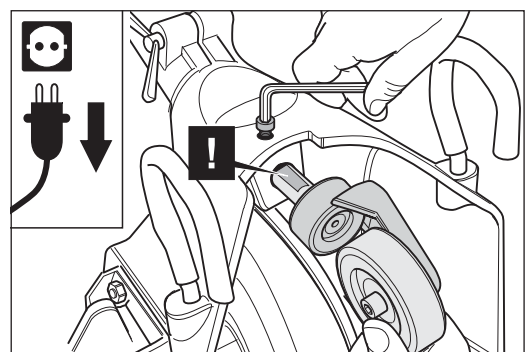

Fig. 98 Release the screw and pull the complete rear wheel assembly out of the machine housing. When mounting, align the clamping surface of the tail axle towards the screw.

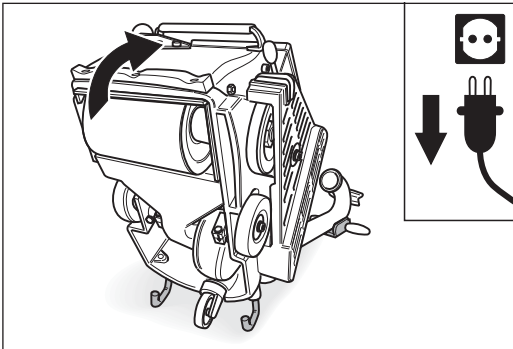

Fig. 99 **Pull the power plug out of the socket!** Tilt the machine backwards. **Ensure that the machine is standing securely!**

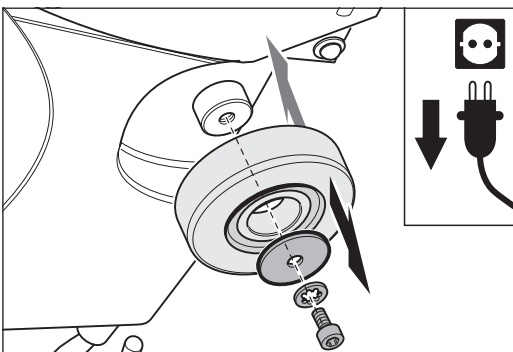

Fig. 100 Remove the screw and washers in the center of the wheel and remove the lateral wheel. Assemble the new wheel in reverse sequence.

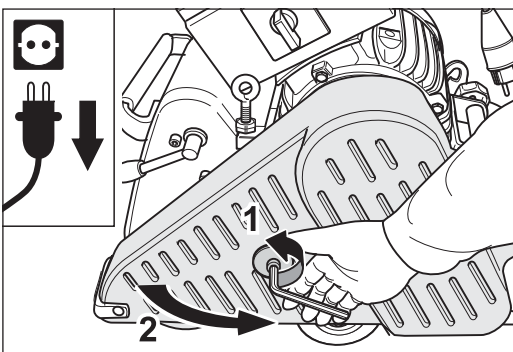

Fig. 101 **Pull the power plug out of the socket** and open the belt guard.

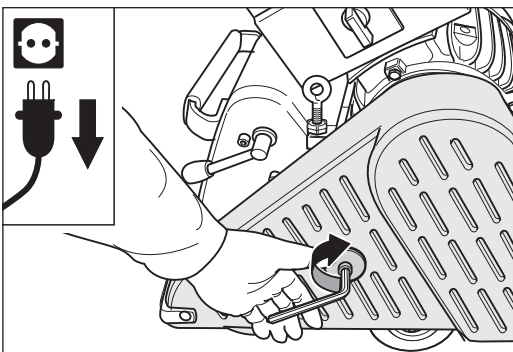

Fig. 102 Close the belt guard.

7.9 REPLACEMENT OF LATERAL WHEELS

Use exclusively original LÄGLER® lateral wheels (part number in *Section 11, Spare parts HUMMEL®!*)

ATTENTION!

For a good sanding result the lateral wheels must always be exchanged in pairs!

- 1 Lift the sanding drum off the floor by turning the lowering lever at the handle upwards (fig. 94).
- 2 **Switch off the machine and pull the power plug out of the socket!**
- 3 Tilt the machine backwards over the safety guards (fig. 99). **Ensure that the machine is standing securely!**
- 4 Release the screw in the center of the wheel and remove the screw and washers (fig. 100). Before removing the **left** lateral wheel open the belt guard (fig. 101).
- 5 Pull the wheel off the wheel lever.
- 6 Push the new wheel onto the wheel lever.
- 7 Mount the washers and the screw.
- 8 Tighten the screw again.
- 9 Close the belt guard (fig. 102).

NOTE:

As it is so easy and quick to exchange the lateral wheels and the back wheel, it is advisable to use a second set of wheels when performing rough work.

7.10 REPLACEMENT AND TENSIONING OF V-BELTS

7.10.1 REPLACEMENT OF V-BELTS

Use exclusively original LÄGLER® V-belts (part number in *Section 11, Spare parts HUMMEL®*)!

- 1 Lift the sanding drum off the floor by turning the lowering lever at the handle upwards (fig. 94).
- 2 **Switch off the machine and pull the power plug out of the socket!**
- 3 Open the belt guard (fig. 101).
- 4 Loosen the two motor nuts at the motor bearing bracket (fig. 103).
- 5 Release the tension of the V-belts by turning the eye bolt at the motor counterclockwise (fig. 104).
- 6 Open the clamping screw of the belt tensioner for the suction V-belt (fig. 105, 1).
- 7 Turn the belt tensioner clockwise to release the tension of the suction V-belt (fig. 105, 2).

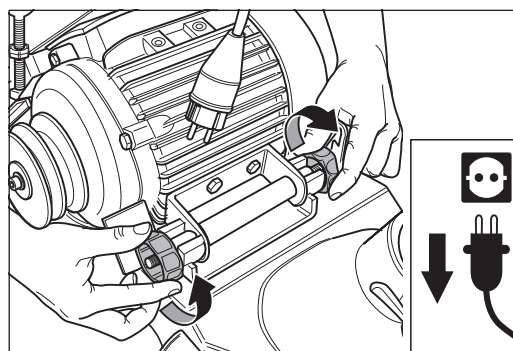

Fig. 103 Loosen the two motor nuts.

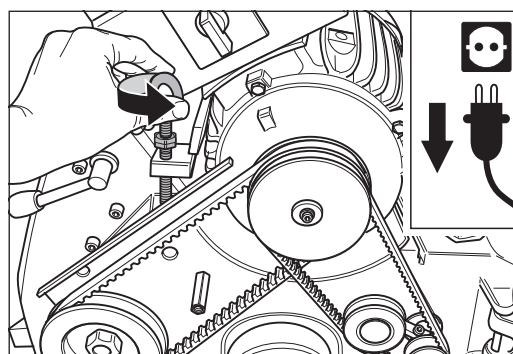

Fig. 104 Release the tension of the V-belts by turning the eye bolt at the motor counterclockwise.

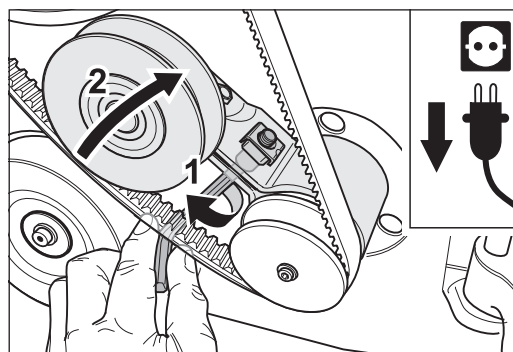

Fig. 105 Open the clamping screw of the belt tensioner (1) and release the tension of the suction V-belt (2).



CAUTION!

RISK OF INJURY:

During dismantling and mounting the V-belts, take care of your fingers → danger of crushing!

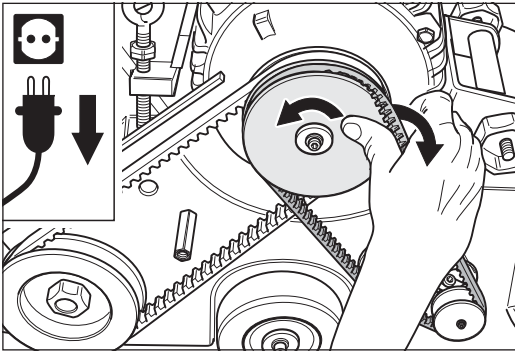

Fig. 106 Remove the suction V-belt.

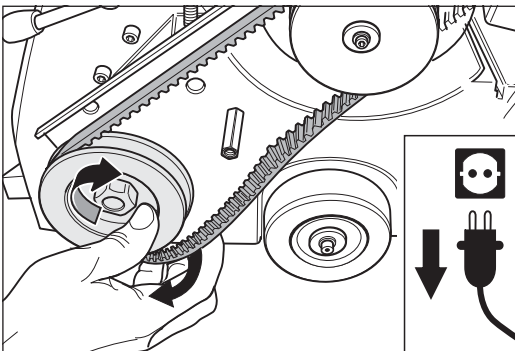

Fig. 107 Allow the drive V-belt to run off the lower pulley. If necessary, use the box wrench (see tool kit) to help you. Turn the pulley **exclusively clockwise** in order not to loosen the nut!

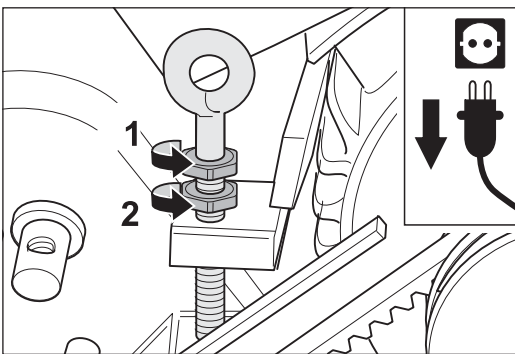

Fig. 108 Loosen the two nuts at the eye bolt at the motor.

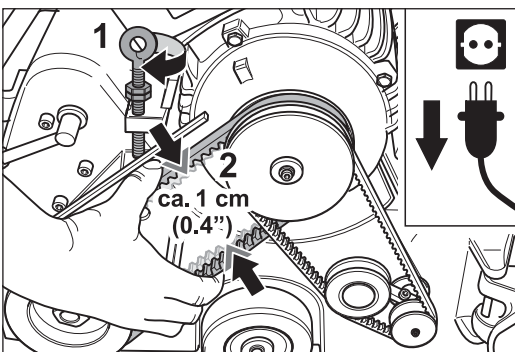

Fig. 109 Tension the drive V-belt by turning the eye bolt at the motor clockwise (1).

Correct tension of the drive V-belt:

The V-belt should be compressed approx. 1 cm (0.4") (2).

- 8 Turn the motor pulley and allow the suction V-belt to run off the motor pulley (fig. 106).
- 9 Turn the lower pulley and allow the drive V-belt to run off the lower pulley (fig. 107).
If necessary, use the box wrench (see tool kit) to turn the lower pulley **exclusively clockwise!**

ATTENTION!

Only turn the nut with the box wrench at the lower pulley clockwise, as otherwise the nut will work loose (left-hand thread)!

- 10 Mount the new V-belts and tension them (→ Section 7.10.2, Tensioning of V-belts).

7.10.2 TENSIONING OF V-BELTS

In case to retension the V-belts only, point 1 to 4 in Section 7.10.1, Replacement of V-belts must be done first. **Only then** proceed as follows.

- 1 Open the clamping screw of the belt tensioner for the suction V-belt (fig. 105, 1).
- 2 Turn the belt tensioner clockwise to release the tension of the suction V-belt (fig. 105, 2).
- 3 Loosen the two nuts at the eye bolt at the motor (fig. 108) and turn them upwards.
- 4 Tension the drive V-belt for the sanding drum by turning the eye bolt at the motor clockwise (fig. 109, 1).

Correct tension of the drive V-belt:

The slack on the V-belt should be approx. 1 cm (0.4") if compressed with normal effort (fig. 109, 2).

- 5 First tighten the lower nut (fig. 110, 1), then the upper nut (fig. 110, 2) at the eye bolt at the motor.

ATTENTION!

Orient the belt tensioner to the fan pulley! Move the belt tensioner accordingly (fig. 111)! A wrong orientation from belt tensioner to fan pulley (fig. 112, A or B) increase the wearing of fan axle, pulleys and V-belt extensive! Then these parts must be replaced significant more often!

- 6 Turn the belt tensioner counterclockwise to tension the suction V-belt (fig. 113, 1). Keep the belt tensioner in position and tighten the clamping screw at the belt tensioner carefully at the same time (fig. 113, 2).

Correct tension of the **suction V-belt:**

The slack on the V-belt should be approx. 1 cm (0.4") if compressed with normal effort (fig. 114).

- 7 Tighten the two motor nuts (fig. 115).

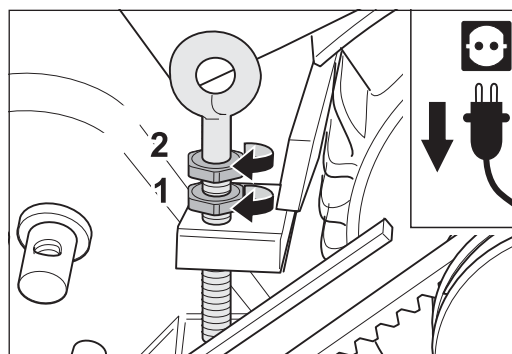

Fig. 110 First tighten the lower nut (1), then the upper nut (2) at the eye bolt at the motor.

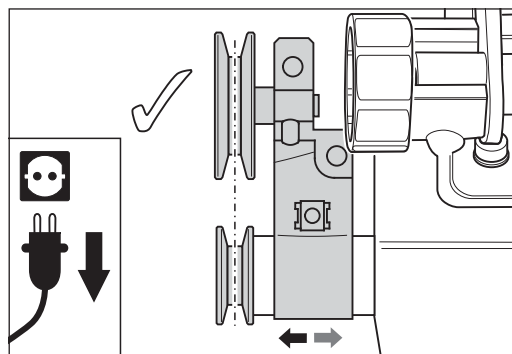

Fig. 111 **Orient the belt tensioner to the fan pulley!** Move the belt tensioner accordingly.

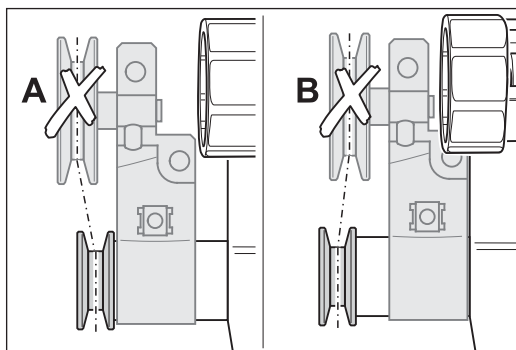

Fig. 112 Avoid position **A** and **B** of the belt tensioner! Otherwise the wearing of fan axle, pulleys and V-belt increase extensive!

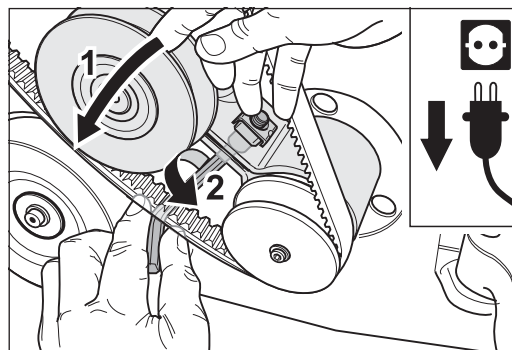

Fig. 113 Tension the suction V-belt by turning the belt tensioner counterclockwise (1 and 2).

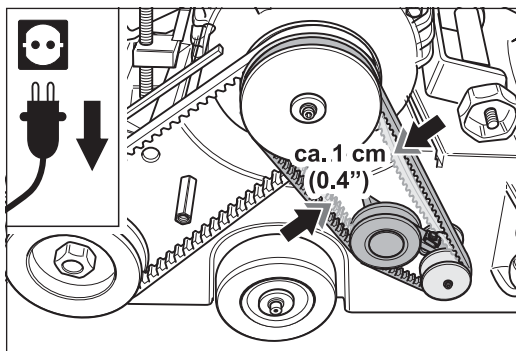

Fig. 114 **Correct tension of the suction V-belt:**
The V-belt should be compressed approx. 1 cm (0.4").

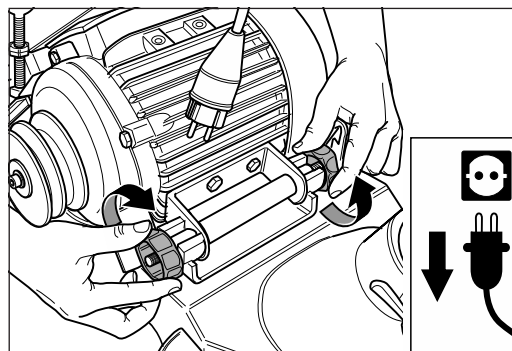

Fig. 115 Tighten the two motor nuts.

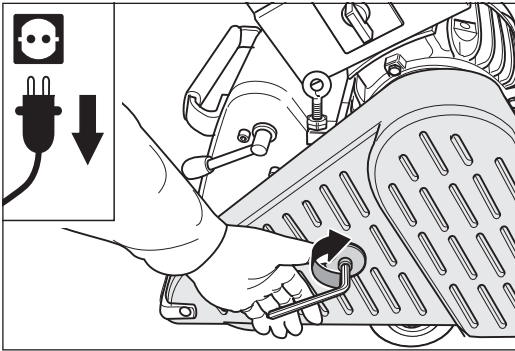

Fig. 116 Close the belt guard.

8 Close the belt guard (fig. 116).

ATTENTION!

- **Never tension the V-belts excessively! This can cause damage to the V-belts and ball bearings!**
- **Check the tension of the V-belts after a while! Retension the V-belts if necessary!**

Regular maintenance and testing in accordance with accident prevention regulations

The electrical operating equipment and machine parts must be inspected at least once a year by a qualified electrician with respect to electrical and mechanical safety, then be repaired as required. Afterwards, the operational safety must be confirmed by the attachment of an inspection label on the machine (fig. 117).

The elements required for the dust suction system must be checked at least once per year by a qualified expert and repaired as required. The functional efficiency must also be confirmed.

Ensure that only original LÄGLER® spare parts are used for maintenance work! You should only allow the customer service work to be conducted by LÄGLER® or an authorized LÄGLER® service center!

The service passport in these operating instructions (*Section 12*) documents when and where your machine was serviced.

Enter the serial number and the year of manufacture of your machine (please see the type plate) on the back cover of these operating instructions! If you do not do this, your service passport is invalid!

Make sure that the maintenance tasks in the service passport are confirmed by filling in a corresponding field with the date, stamp and signature.

REGULATIONS VALID IN GERMANY

The German Ordinance on Industrial Safety and Health (BetrSichV) requires every employer to define the testing intervals on the work equipment they provide according to a risk analysis and to document all of this.



WARNING!

Tests and testing intervals must comply with and be performed in accordance with the applicable regulations and legal requirements in your country!

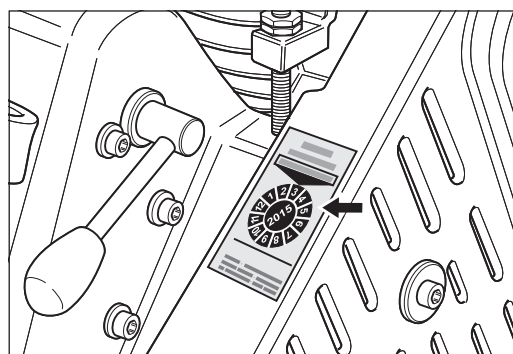

Fig. 117 The inspection label on the belt guard confirms the electrical and mechanical safety of the machine and indicates when the next maintenance check is due.



WARNING!

In order to ensure the safety of the machines and equipment (= working equipment), the German Ordinance on Industrial Safety and Health (BetrSichV) must be complied with in Germany!

NOTE:

- All LÄGLER® machines and electrical equipment are subjected to an electrical inspection as well as a thorough visual and functional test before they leave the factory.
- A recurring inspection of the machines and electrical equipment must be conducted in Germany at certain intervals.
- LÄGLER® recommends using the guidelines of the German accident prevention regulations “DGUV Vorschrift 3” for inspections and inspection intervals.
- You can, of course, arrange for repairs and recurring inspections of LÄGLER® machines to be conducted by the LÄGLER® service department.

EXCERPT FROM THE GERMAN ACCIDENT PREVENTION REGULATIONS “DGUV VORSCHRIFT 3” (November 2013)

§ 5 Inspections

- (1) The employer must ensure that the proper condition of the electrical systems and equipment is inspected
 1. before using the equipment for the first time and after an alteration or repair before being used again by an electrician or under the supervision of an electrician and
 2. at regular intervals.

The intervals are to be calculated in such a manner that defects which must be handled are detected in a timely manner.

- (2) The electrical engineering regulations relevant to the inspection are to be followed.
- (3) Upon request by the professional association, an inspection log with specific entries is to be maintained.
- (4) The inspection before the first commissioning as per paragraph 1 is not required if the employer receives confirmation from the manufacturer or installer that the electrical systems and equipment have been correspondingly procured in accordance with these accident prevention guidelines.

Table 1B: Recurring inspections of portable electrical equipment:

Systems/equipment (which are to be inspected)

- portable electrical equipment (insofar as is used)
- extension and device connection cables with plugs
- connection cables with plugs
- movable cables with plugs and fixed connections

Inspection interval

Every 6 months as a reference value, **3 months on construction sites***).

If an error rate of less than 2% is reached during the inspection, the inspection interval can be extended to a maximum of 1 year (valid for machines on construction sites, in production facilities and workshops).

*) See the BG information “Selection and Operation of Electrical Systems and Equipment on Construction Sites” (DGUV Information 203-006) for more details.

Type of inspection

The proper condition of the machines and equipment must be inspected.

Inspector

Electricians or persons trained in electrical engineering when using suitable measurement and inspection devices.

Causes of faults

This section shows you how to remedy possible malfunctions. If none of the measures listed here are successful, please contact our service department, your retailer or your importer.

9.1 THE MACHINE DOES NOT RUN OR HAS SWITCHED OFF AUTOMATICALLY

- The machine is not connected to the electrical network. Check the following items:
 - Is the motor cable connected to the extension cable?
 - Is the extension cable inserted into the power socket?
- The power socket is not properly connected. This error must be corrected by an expert.
- The electrical safety device of the electrical network interrupted the electrical circuit, e.g. because
 - too many electricity consumers are connected to the same electrical circuit,
 - improper electrical installation.
 The causes for the error must be repaired by an expert.
- The electrical network is not providing sufficient voltage (undervoltage). Use a transformer if necessary (e.g. LÄGLER® part number 708.00.00.100 for 230 V).
- The temperature switch in the motor has switched off the machine because
 - the power cables have a total length of more than 20 m (790"),
 - the power cables have wire cross-sections which are too small:
 - at mains voltage 220 V or 230 V are the wire cross-sections smaller than 2.5 mm² (0.0039 sq.in.),
 - at mains voltage 400 V are the wire cross-sections smaller than 1.5 mm² (0.0023 sq.in.),
 - or too much pressure was applied to the sanding drum while sanding.
 The motor must cool off and the causes for the problems named above must be remedied.
- An electrical component of the machine (e.g. capacitors, contactor, cable, switch) is defective and must be inspected by a qualified electrician and replaced if necessary.



WARNING!

RISK OF DEATH from electrical shock:

Work on the electrical equipment is to be conducted exclusively by a qualified electrician! The machine must be switched off and the power plug removed from the socket during this work!

The circuit diagram valid for your machine is located in the motor switch box!

RISK OF INJURY due to unsuitable parts:

Make sure that only original LÄGLER® spare parts and original LÄGLER® accessories are used!

- Machine for mains voltage 400 V:
The rotation direction of the motor is wrong. The phase changing switch in the plug of the motor cable must be turned 180°.
➔ *Section 4.3.2, Machines with three-phase AC motor*

9.2 THE MACHINE ATTEMPTS TO START UP BUT IS NOT ABLE TO DO SO

- At low temperatures: The machine is too cold and must be heated up to room temperature in a warm room.
- Cables which are too long or too thin are used for the electrical connection:
 - The power cables have a total length of more than 20 m (790").
 - The power cables have wire cross-sections which are too small:
 - at mains voltage 220 V or 230 V are the wire cross-sections smaller than 2.5 mm² (0.0039 sq.in.),
 - at mains voltage 400 V are the wire cross-sections smaller than 1.5 mm² (0.0023 sq.in.).
 This causes of faults lead to a loss of power and are not allowed for safety reasons!
- The electrical network is not providing sufficient voltage (undervoltage). Use a transformer if necessary (e.g. LÄGLER® part number 708.00.00.100 for 230 V).
- The V-belts are too tight and must be loosened.
➔ *Section 7.10, Replacement and tensioning of V-belts*

9.3 THE MACHINE RUNS BUT HAS NO OR VERY LITTLE SANDING POWER CAPACITY

- The sanding medium is incorrect or dull and must be replaced.
➔ *Section 5.3, Changing the sanding belt*
- At low temperatures: The machine is too cold and must be heated up to room temperature in a warm room.
- Cables which are too long or too thin are used for the electrical connection:
 - The power cables have a total length of more than 20 m (790").
 - The power cables have wire cross-sections which are too small:
 - at mains voltage 220 V or 230 V are the wire cross-sections smaller than 2.5 mm² (0.0039 sq.in.),
 - at mains voltage 400 V are the wire cross-sections smaller than 1.5 mm² (0.0023 sq.in.).

This causes of faults lead to a loss of power and are not allowed for safety reasons!
- The electrical network is not providing sufficient voltage (undervoltage). Use a transformer if necessary (e.g. LÄGLER® part number 708.00.00.100 for 230 V).
- The V-belts are not tight enough and must be tightened a bit.
➔ *Section 7.10, Replacement and tensioning of V-belts*
- The sanding pressure do not suit to the grit grade of the sanding belt and must be corrected.
➔ *Section 5.2, Regulating the sanding drum pressure*

9.4 THE MACHINE VIBRATES INTENSELY AND RUNS NOISILY

- The sanding medium does not have the proper tension. The tension must be corrected.
➔ *Section 5.3, Changing the sanding belt*
- The sanding medium is damaged or incorrect and must be replaced.
➔ *Section 5.3, Changing the sanding belt*
- The sanding belt tracking is incorrect and must be adjusted.
➔ *Section 7.3, Checking and setting the sanding belt tracking*
- The sanding drum is dirty or damaged and must be replaced.
➔ *Section 7.6, Replacement of sanding drum*
- The tensioning roller of the drive unit is dirty, damaged or worn-out and must be replaced.
➔ *Section 7.7, Replacement of tensioning roller*
- A V-belt is dirty, damaged or worn-out and must be replaced.
➔ *Section 7.10, Replacement and tensioning of V-belts*
- A pulley is dirty, damaged or worn-out and must be cleaned or replaced.
- There are clogged materials and deposits in the machine that must be removed.

9.5 THE MACHINE RUNS BUT CREATES A GREAT DEAL OF DUST

- The dust bag is more than one third full and must be emptied.
➔ *Section 5.4, Emptying the dust bag*
- The dust bag is not correctly attached or is damaged and must be replaced.
➔ *Section 4.1, Preparing the machine for operation*
- The sealing felt at the machine housing is damaged and must be replaced.
➔ *Section 7.5, Checking the dust pick-up*
- There are clogged materials and deposits in the machine that must be removed.
- The suction V-belt is not tight enough and must be tightened or damaged and must be replaced.
➔ *Section 7.10, Replacement and tensioning of V-belts*
- The side cover is not mounted at the machine and must be mounted (➔ fig. 20).

9.6 SANDING PROBLEMS (WAVES, STRIPS, GROOVES)

- The floor was not vacuumed before sanding. The floor must be vacuumed thoroughly always directly before each sanding step.
- The sanding drum was not lifted from the floor while the machine was switched on or off. Always lift the sanding drum off the floor before switching on or off the machine.
 - ➔ *Section 4.3, Switching on the machine*
 - ➔ *Section 4.4, Switching off the machine*
- The sanding medium does not have the proper tension. The tension must be corrected.
 - ➔ *Section 5.3, Changing the sanding belt*
- The sanding medium is damaged or incorrect and must be replaced.
 - ➔ *Section 5.3, Changing the sanding belt*
- The sanding pressure do not suit to the grit grade of the sanding belt and must be corrected.
 - ➔ *Section 5.2, Regulating the sanding drum pressure*
- The machine setting is incorrect and must be adjusted. The sanding drum must sands centrally.
 - ➔ *Section 7.4, Checking the machine setting*
- The sanding drum is dirty, damaged or worn-out and must be replaced.
 - ➔ *Section 7.6, Replacement of sanding drum*
- The tensioning roller of the drive unit is dirty, damaged or worn-out and must be replaced.
 - ➔ *Section 7.7, Replacement of tensioning roller*
- The wheels are dirty or damaged and must be cleaned or replaced.
 - ➔ *Section 7.8, Replacement of rear wheel*
 - ➔ *Section 7.9, Replacement of lateral wheels*
- A V-belt is dirty, damaged or worn-out and must be replaced.
 - ➔ *Section 7.10, Replacement and tensioning of V-belts*
- A pulley is dirty, damaged or worn-out and must be cleaned or replaced.
- The lowering rod linkage is running poorly, catching on something or getting stuck. Free movement is necessary.
- The machine is being moved too slowly and must be sped up.

CAUSES OF FAULTS

- Too much pressure is placed on the sanding drum while sanding.

The following causes must be eliminated:

- additional weight is on the machine,
- the rear part of the machine is lifted on with the handle while sanding,
- the lowering lever at the handle is pressed downwards while sanding.

CIRCUIT DIAGRAMS

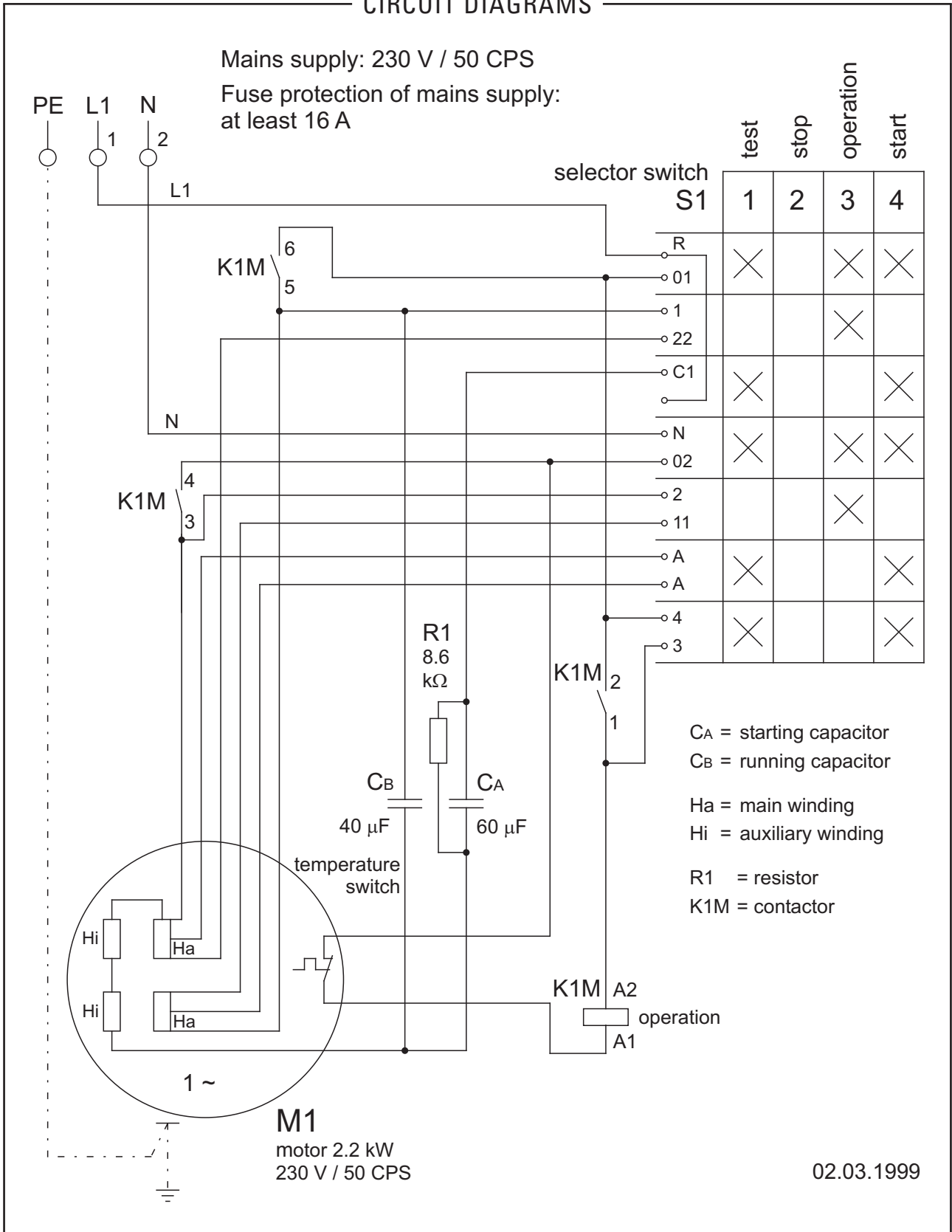

HUMMEL® + ELF: single-phase AC motor		2.2 kW / 230 V / 50 CPS
EUGEN LÄGLER GMBH Kappelrain 2 D-74363 Güglingen-Frauenzimmern	Phone: 0049 - 7135 - 98 90 - 0 Fax: 0049 - 7135 - 98 90 - 98	e-mail: info@laegler.com Internet: http://www.laegler.com

The circuit diagram valid for your machine is located in the motor switch box.

CIRCUIT DIAGRAMS

Mains supply: 220 + 230 V / 60 CPS
 Fuse protection of mains supply:
 at least 20 A

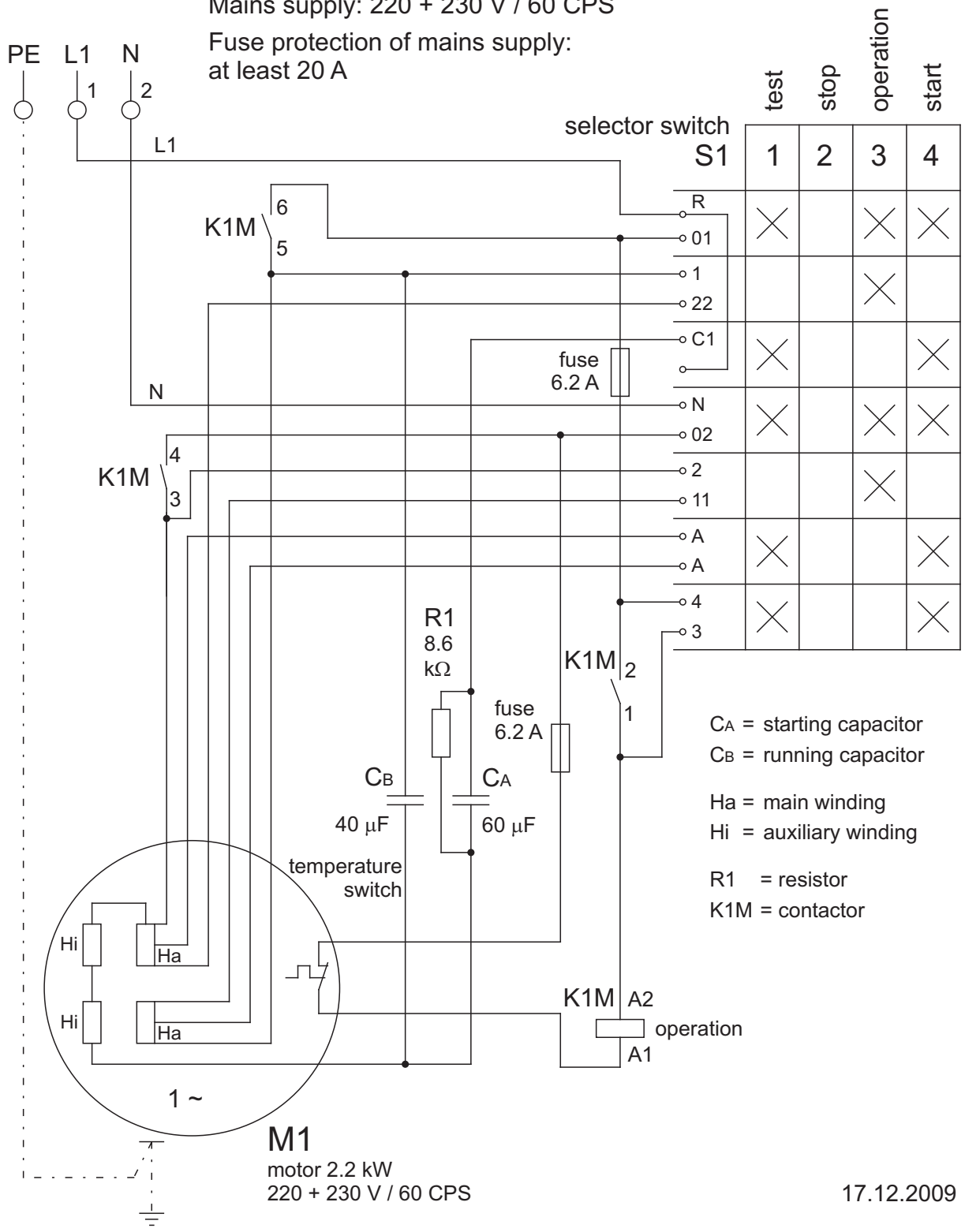

	test	stop	operation	start
selector switch S1	1	2	3	4
R	×		×	×
01			×	
1			×	
22			×	
C1	×			×
N	×		×	×
02	×		×	×
2			×	
11			×	
A	×			×
A	×			×
4	×			×
3	×			×

CA = starting capacitor
 CB = running capacitor
 Ha = main winding
 Hi = auxiliary winding
 R1 = resistor
 K1M = contactor

M1
 motor 2.2 kW
 220 + 230 V / 60 CPS

17.12.2009

HUMMEL® + ELF: single-phase AC motor		2.2 kW / 220 V / 60 CPS 2.2 kW / 230 V / 60 CPS
EUGEN LÄGLER GMBH Kappelrain 2 D-74363 Güglingen-Frauenzimmern	Phone: 0049 - 7135 - 98 90 - 0 Fax: 0049 - 7135 - 98 90 - 98	e-mail: info@laegler.com Internet: http://www.laegler.com

The circuit diagram valid for your machine is located in the motor switch box.

CIRCUIT DIAGRAMS

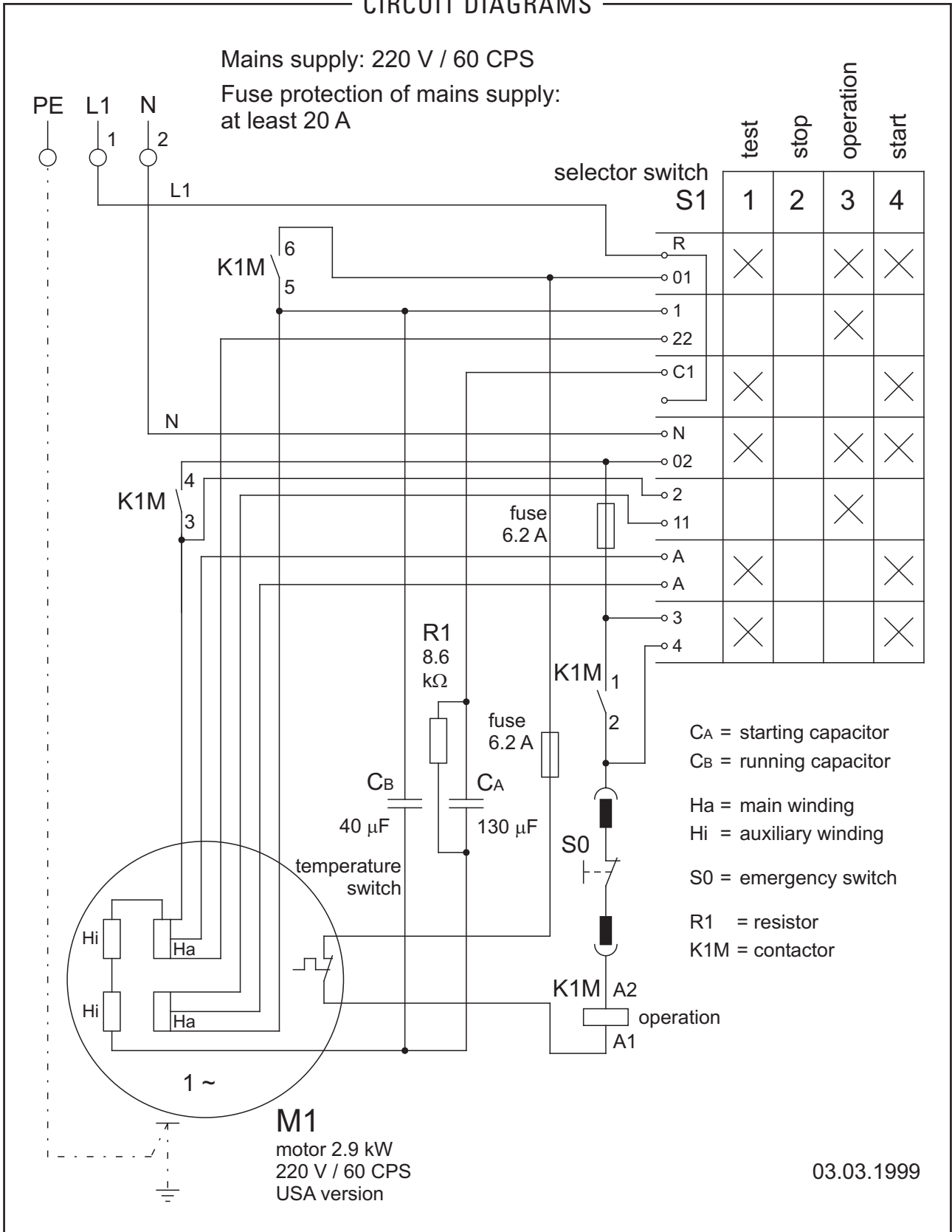

HUMMEL® + ELF: single-phase AC motor		2.9 kW / 220 V / 60 CPS USA version
EUGEN LÄGLER GMBH Kappelrain 2 D-74363 Güglingen-Frauenzimmern	Phone: 0049 - 7135 - 98 90 - 0 Fax: 0049 - 7135 - 98 90 - 98	e-mail: info@laegler.com Internet: http://www.laegler.com

The circuit diagram valid for your machine is located in the motor switch box.

SPARE PARTS HUMMEL®

ATTENTION: Please specify in inquiries and spare part orders always the serial numbers of your machines (→ Section 3.1)!

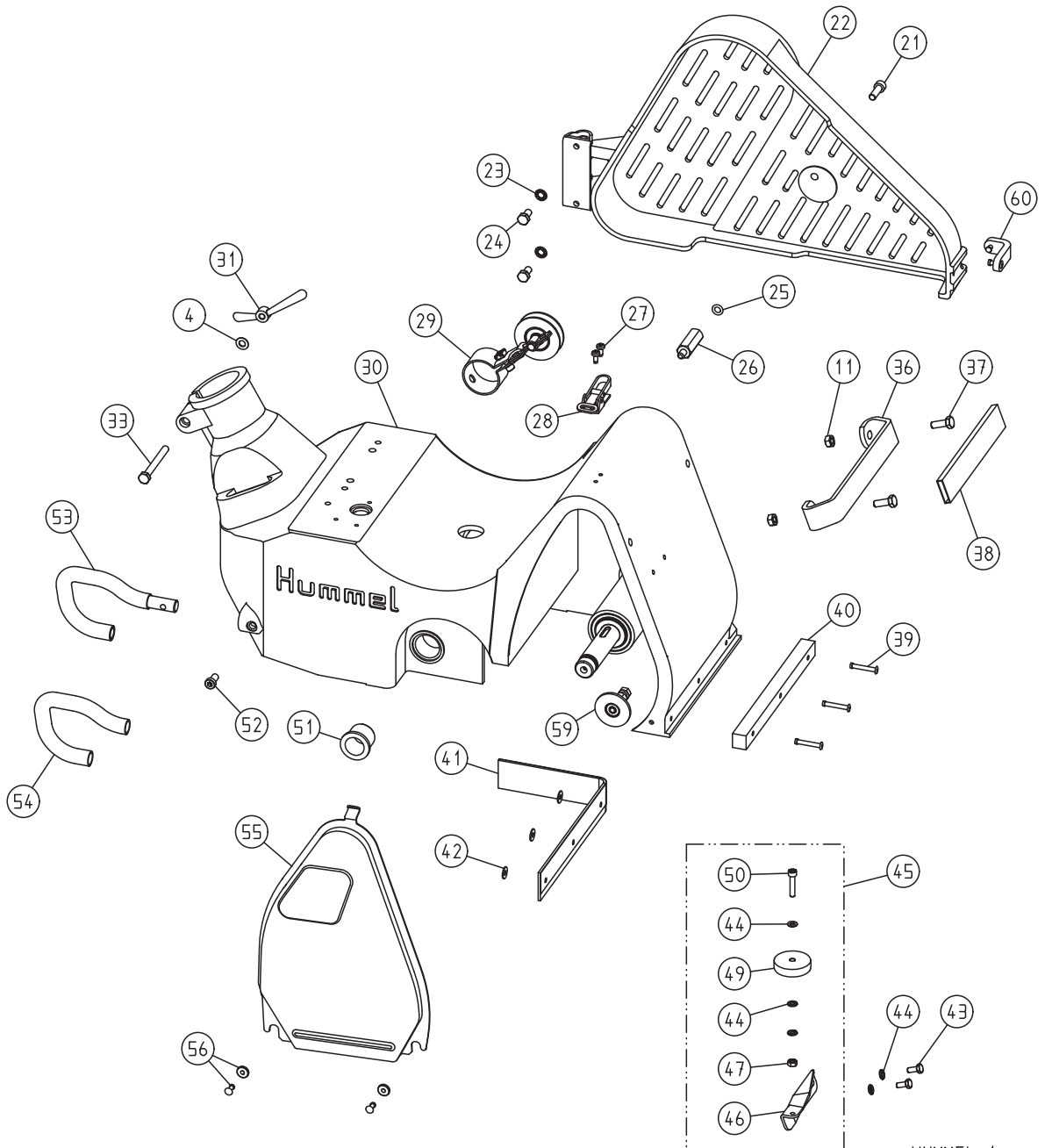

HUMMEL 1
01.11.2014

Item	Part number	Description
4	0125.1008.000	Washer
11	0980.1008.000	Nut
21	0912.1008.025	Screw
22	100.50.00.100	Belt guard, complete
23	6797.1008.000	Washer
24	0933.1008.016	Screw
25	000.01.40.001	O-ring
26	100.50.04.105	Screw stud
27	7500.1005.012	Screw
28	100.01.05.105	Cover fastener
29	100.58.00.200	Belt tensioner, complete
30	100.01.00.100	Machine housing
31	000.20.45.083	Wing nut
33	0931.1008.075	Screw
36	100.33.01.100	Bracket
37	0933.1008.022	Screw
38	100.33.02.100	Grip
39	7337.1005.033	Rivet
40	100.01.01.100	Bumper felt
41	100.01.02.100	Sealing felt
42	9021.1005.000	Washer
43	0933.1006.014	Screw
44	0125.1006.000	Washer
45	100.60.00.200	Wall-protecting roller with holder
46	100.60.01.100	Holder for wall-protecting roller
47	0934.1006.000	Nut
49	100.60.02.200	Wall-protecting roller
50	0912.1006.030	Screw
51	000.43.10.252	Plastic bushing
52	7984.1008.016	Screw
53	100.44.00.100	Safety guard, complete
54	100.44.01.100	PVC tube
55	100.01.03.100	Side cover
56	100.01.08.200	Collar nut, complete
59	100.01.30.100	Guide roller, complete
60	100.50.05.100	Bumper guard with rivets

ATTENTION: Please specify in inquiries and spare part orders always the serial numbers of your machines (→ Section 3.1)!

SPARE PARTS HUMMEL®

ATTENTION: Please specify in inquiries and spare part orders always the serial numbers of your machines (→ Section 3.1)!

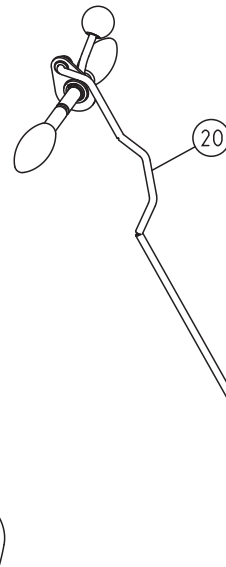
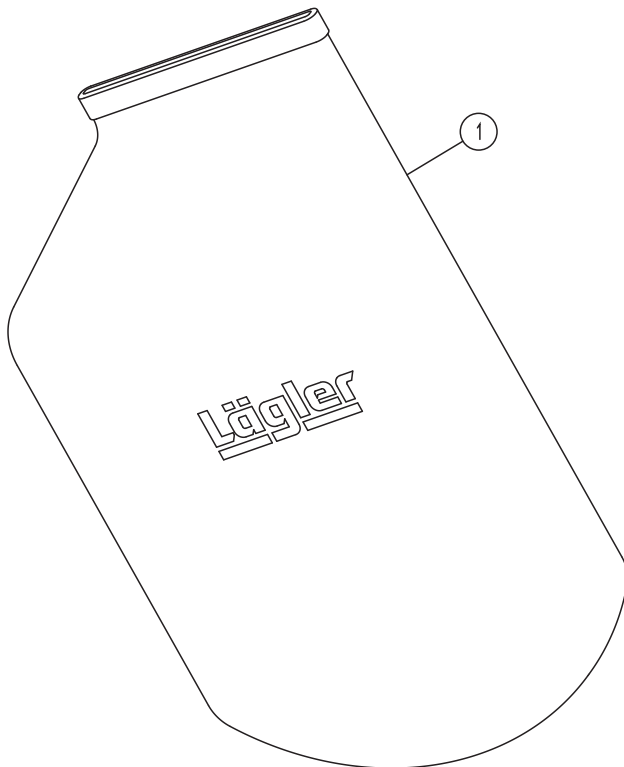
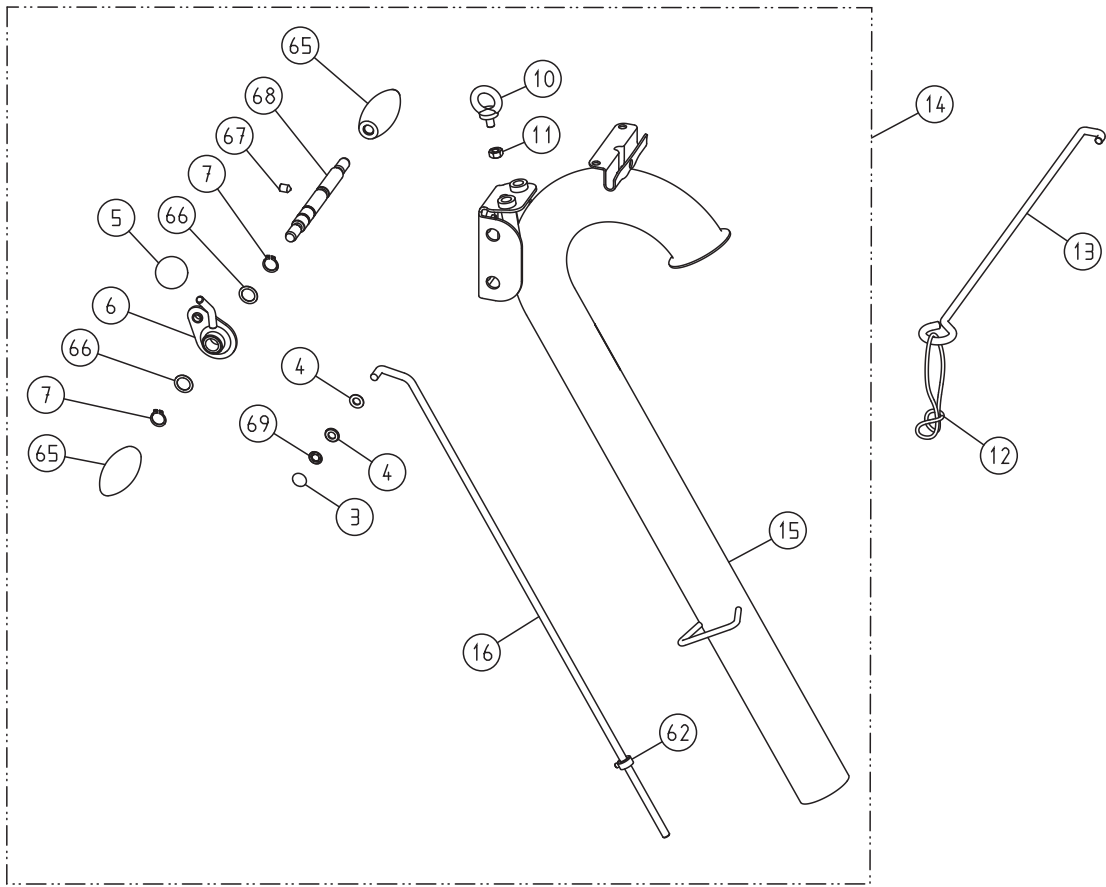

HUMMEL 2
01.02.2015

Item	Part number	Description
1	100.00.80.105	Dust bag HUMMEL®
3	000.17.21.081	Fixing cap
4	0125.1008.000	Washer
5	000.20.56.351	Ball knob
6	100.20.18.200	Lever
7	0471.0015.000	Circlip
10	0580.1008.000	Thread eye
11	0980.1008.000	Nut
12	00.000.41.002	Strain relief ring
13	100.20.26.100	Cable support, complete
14	100.20.00.200	Guide tube, complete
	102.20.00.200	Guide tube USA, complete
	100.21.00.200	Guide tube long, complete
15	100.20.01.200	Guide tube
	102.20.01.200	Guide tube USA
16	100.20.24.100	Upper rod, complete
20	100.20.90.200	Upper rod HUMMEL®/ELF for sinistrals, complete (conversion set)
62	100.20.23.200	Adjusting ring, complete
65	000.20.31.351	Handle
66	0988.0015.005	Washer
67	0914.0008.012	Grub screw
68	100.20.17.200	Axle for handle
69	000.17.20.081	Quick-fixing-fastener

ATTENTION: Please specify in inquiries and spare part orders always the serial numbers of your machines (→ Section 3.1)!

SPARE PARTS HUMMEL®

ATTENTION: Please specify in inquiries and spare part orders always the serial numbers of your machines (→ Section 3.1)!

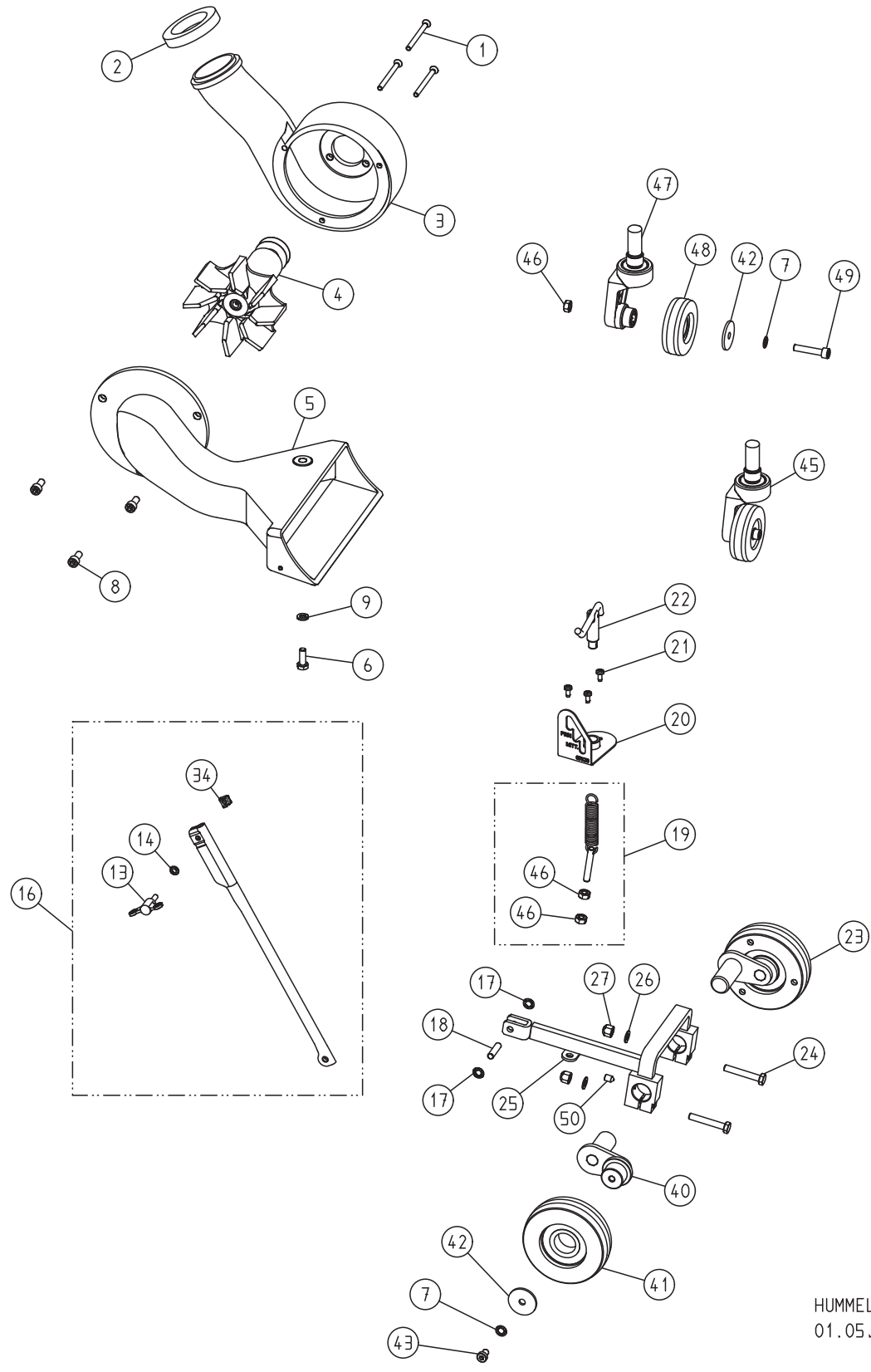

HUMMEL 3
01.05.2015

Item	Part number	Description
1	0965.1006.870	Screw
2	100.08.01.200	Sealing ring
3	100.08.00.100	Fan housing
4	100.10.00.200	Fan insert, complete
5	100.14.00.100	Intake duct
6	0933.1008.022	Screw
7	6797.1008.000	Washer
8	0912.1008.018	Screw
9	0127.1008.000	Spring washer
13	000.20.46.062	Wing screw
14	0125.1006.000	Washer
16	100.04.09.100	Lower rod, complete
17	000.17.20.081	Quick-fixing-fastener
18	100.04.01.200	Pivot pin
19	100.04.25.100	Spring with screw, complete
20	100.04.06.200	Notch plate
21	7500.1005.012	Screw
22	100.04.02.100	Spring tensioner, complete
23	100.05.00.200	Lateral wheel, complete
24	0931.1008.050	Screw
25	100.04.00.100	Lifting fixture
26	0125.1008.000	Washer
27	6330.1008.000	Nut
34	000.50.12.061	Nut
40	100.05.04.200	Wheel arm
41	100.05.29.100	Lateral wheel
42	000.10.10.085	Washer
43	7984.1008.012	Screw
45	100.18.00.300	Rear wheel, complete
46	0934.1008.000	Nut
47	100.18.18.300	Tail axle housing, complete
48	100.18.29.105	Rear wheel (from year of manufacture 2002)
	100.18.09.200	Rear wheel (up to year of manufacture 2001)
49	0912.1008.040	Screw
50	0914.0008.012	Grub screw

ATTENTION: Please specify in inquiries and spare part orders always the serial numbers of your machines (→ Section 3.1)!

SPARE PARTS HUMMEL®

ATTENTION: Please specify in inquiries and spare part orders always the serial numbers of your machines (→ Section 3.1)!

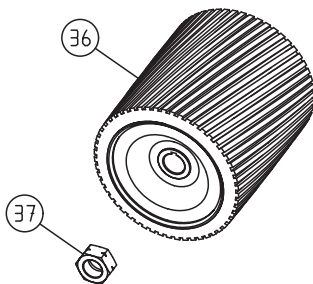
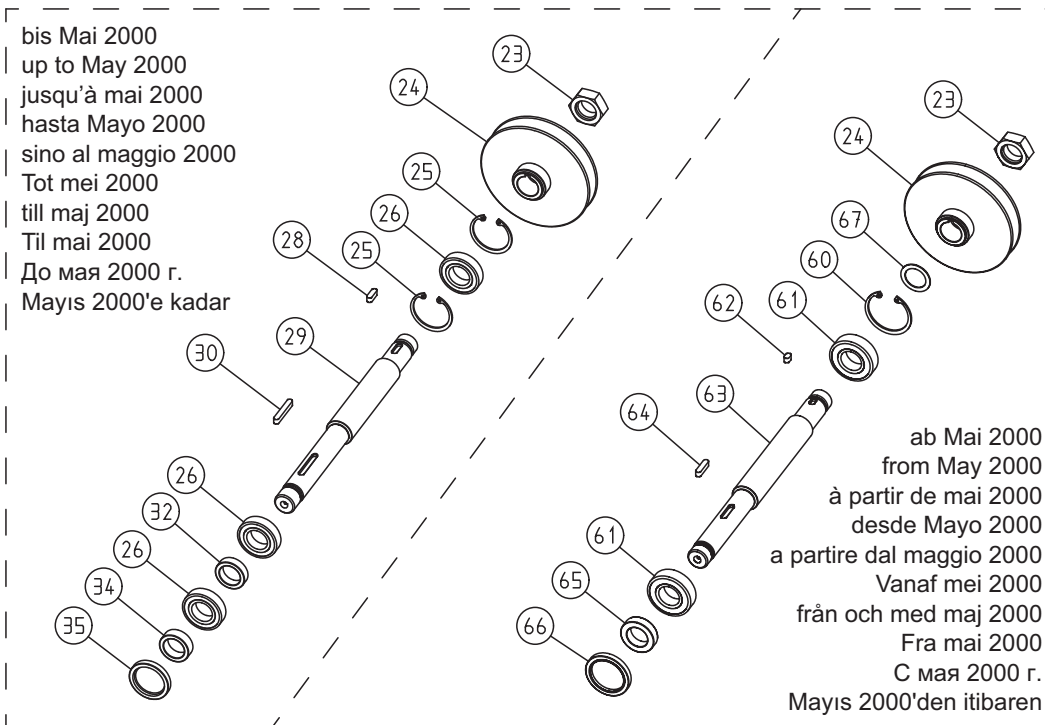
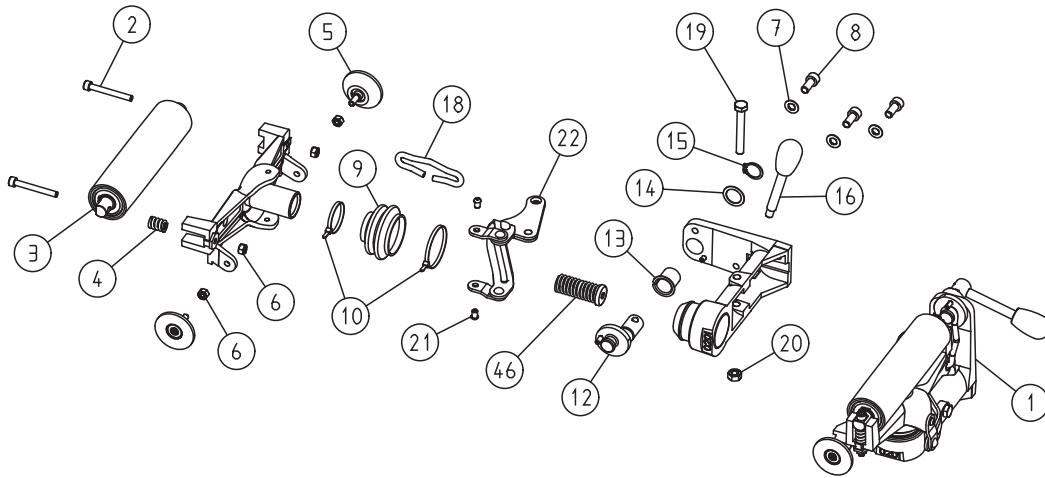

HUMMEL 4
01.06.2013

Item	Part number	Description
1	100.45.00.100	Drive unit, complete
2	0912.1006.050	Screw
3	100.45.12.105	Tensioning roller
4	000.31.13.021	Pressure spring
5	100.45.01.105	Guide roller
6	0980.1006.000	Nut
7	0125.1008.000	Washer
8	0912.1008.018	Screw
9	100.45.81.105	Collar
10	000.61.10.363	Cable tie
12	100.45.20.100	Crank
13	100.45.24.105	Bearing bush
14	0988.0018.005	Washer
15	0471.0018.000	Circlip
16	000.20.32.104	Operating lever
18	100.45.17.100	Clip
19	0931.1008.060	Screw
20	0980.1008.000	Nut
21	100.45.61.205	Screw
22	100.45.37.100	Double arm, complete
23	100.02.05.100	Nut, right-hand thread
24	100.36.00.100	V-belt pulley
25	0472.0047.000	Circlip
26	6005.0025.205	Ball bearing
28	6885.0606.018	Parallel key
29	100.02.01.100	Sanding shaft
30	6885.0606.040	Parallel key
32	100.02.04.105	Spacer ring
34	100.02.03.105	Slide ring
35	000.11.35.102	Shaft seal
36	120.40.00.100	Sanding drum HUMMEL®
	120.41.00.100	Sanding drum HUMMEL®, hard rubber cover
37	100.02.06.100	Nut, left-hand thread
46	100.45.45.100	Pressure spring
60	0472.0052.000	Circlip
61	6205.0025.205	Ball bearing
62	6885.0606.010	Parallel key
63	100.02.01.200	Sanding shaft
64	6885.0606.025	Parallel key
65	100.02.03.200	Spacer ring
66	000.11.40.102	Shaft seal
67	0988.0025.010	Washer

ATTENTION: Please specify in inquiries and spare part orders always the serial numbers of your machines (→ Section 3.1)!

Item	Part number	Description
1	100.65.00.100	Motor, 230 V / 50 CPS / 2.2 kW
	101.65.00.100	Motor, 230 V / 60 CPS / 2.2 kW
	102.65.00.100	Motor, 220 V / 60 CPS / 2.9 kW, USA
	105.65.00.100	Motor, 400 V / 50 CPS / 4.0 kW, three-phase current
2	000.70.17.092	V-belt
3	000.70.10.067	V-belt
4	0912.1008.020	Screw
5	0127.1008.000	Spring washer
6	100.65.29.200	Motor bearing bracket
7	0933.1008.020	Screw
9	100.65.30.100	Motor nut
10	100.65.25.100	Motor mounting
11	100.65.09.100	Fan cover
12	7500.1005.006	Screw
13	0471.0030.000	Circlip
14	100.65.08.105	Fan wheel
16	6885.0807.020	Parallel key
17	6885.0606.025	Parallel key
18	100.65.06.100	Motor pulley
19	000.10.10.061	Washer
20	0912.1006.014	Screw
21	100.65.80.205	Eye bolt
22	100.65.35.100	Motor tensioner
23	0933.1008.022	Screw
26	100.65.75.100	Motor cable 3 x 2.5 mm ² (from year of manufacture 2008)
	000.65.43.251	Motor cable 3 x 2.5 mm ² (up to year of manufacture 2007)
	102.65.75.100	Motor cable 3 x 2.5 mm ² , USA (from year of manufacture 2008)
	000.65.43.257	Motor cable 3 x 2.5 mm ² , USA (up to year of manufacture 2007)
	105.65.75.100	Motor cable 5 x 1.5 mm ² for three-phase AC motor (from year of manufacture 2008)
	000.65.45.151	Motor cable 5 x 1.5 mm ² for three-phase AC motor (up to year of manufacture 2007)
27	100.65.40.200	Switch box for 230 V / 50 CPS
	102.65.40.200	Switch box for 220-230 V / 60 CPS + three-phase current
28	000.65.10.041	Running capacitor 40 µF
29	000.65.62.211	Switch button
30	000.65.60.253	Switch
	000.65.60.401	Switch for three-phase AC motor
31	000.65.10.061	Starting capacitor 60 µF
	000.65.10.131	Starting capacitor 130 µF, USA
32	000.65.20.035	Contacto
	000.65.20.032	Contacto complete for three-phase AC motor
33	102.65.60.200	Emergency switch USA, complete
34	000.65.62.221	Red button for emergency switch USA
35	000.65.25.020	Lamp red for three-phase AC motor
36	000.65.20.220	Relay for three-phase AC motor
37	100.65.14.105	Sealing plate
38	000.65.12.091	Discharging resistor
39	000.68.60.207	Nut (from year of manufacture 2008)
	000.68.60.163	Nut (up to year of manufacture 2007)
40	100.65.47.100	Cover with seal

ATTENTION: Please specify in inquiries and spare part orders always the serial numbers of your machines (→ Section 3.1)!

SPARE PARTS HUMMEL®

ATTENTION: Please specify in inquiries and spare part orders always the serial numbers of your machines (→ Section 3.1)!

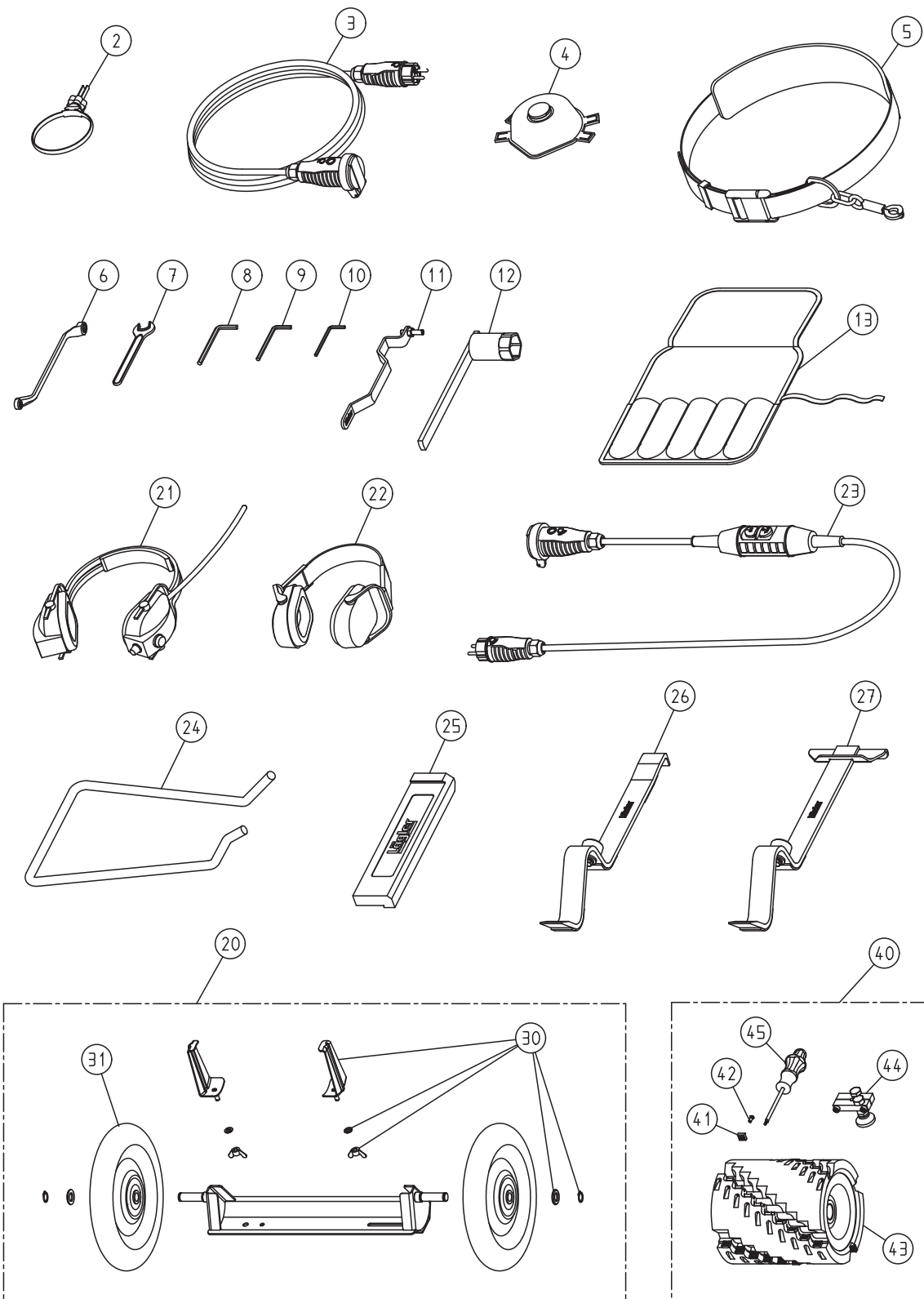

HUMMEL 6
01.05.2015

Item	Part number	Description
2	000.01.40.110	MultiClip
3	000.65.53.251	Extension cable 3 x 2.5 mm ² , 10 m long
	000.65.53.252	Extension cable 3 x 2.5 mm ² , 20 m long
	000.65.55.151	Extension cable 5 x 1.5 mm ² , 10 m long, for three-phase AC motor
4	000.01.20.010	Respiratory protection mask P3
5	000.01.50.010	Safety belt
6	000.95.21.103	Closed mouth wrench 10/13 mm
7	000.95.11.171	Open mouth wrench 17 mm
8	000.93.11.061	Hexagonal socket screw wrench 6 mm
9	000.93.11.051	Hexagonal socket screw wrench 5 mm
10	000.93.11.041	Hexagonal socket screw wrench 4 mm
11	100.00.50.100	Setting fixture
12	100.00.45.105	Box wrench
13	000.01.30.011	Tool bag, empty
	100.98.00.100	Tool bag, complete
20	720.00.00.200	Trolley TRANSCART, complete
21	000.01.10.011	Foldable earmuff type MUSIMUFF with FM radio
22	000.01.10.021	Foldable earmuff type POCKET
23	000.01.65.020	Safety switch PRCD-S (for German mains supply)
24	100.00.55.100	Carrying handle HUMMEL®
25	701.10.00.100	Impact tool
26	702.00.00.200	Parquet layer tool ZUGEISEN, small
27	703.00.00.200	Parquet layer tool ZUGEISEN, broad
30	720.10.00.200	Accessories TRANSCART
31	720.05.00.205	Wheel TRANSCART
40	000.10.42.240	Milling drum 200 mm width, complete with accessories
41	900.02.45.105	Carbide indexable insert (10 pieces per box)
42	900.02.47.105	Screw for indexable insert
43	000.10.42.241	Milling drum with indexable inserts
44	000.10.42.243	Cutting depth adjustment, complete
45	000.91.30.151	Torx screwdriver T15

ATTENTION: Please specify in inquiries and spare part orders always the serial numbers of your machines (→ Section 3.1)!

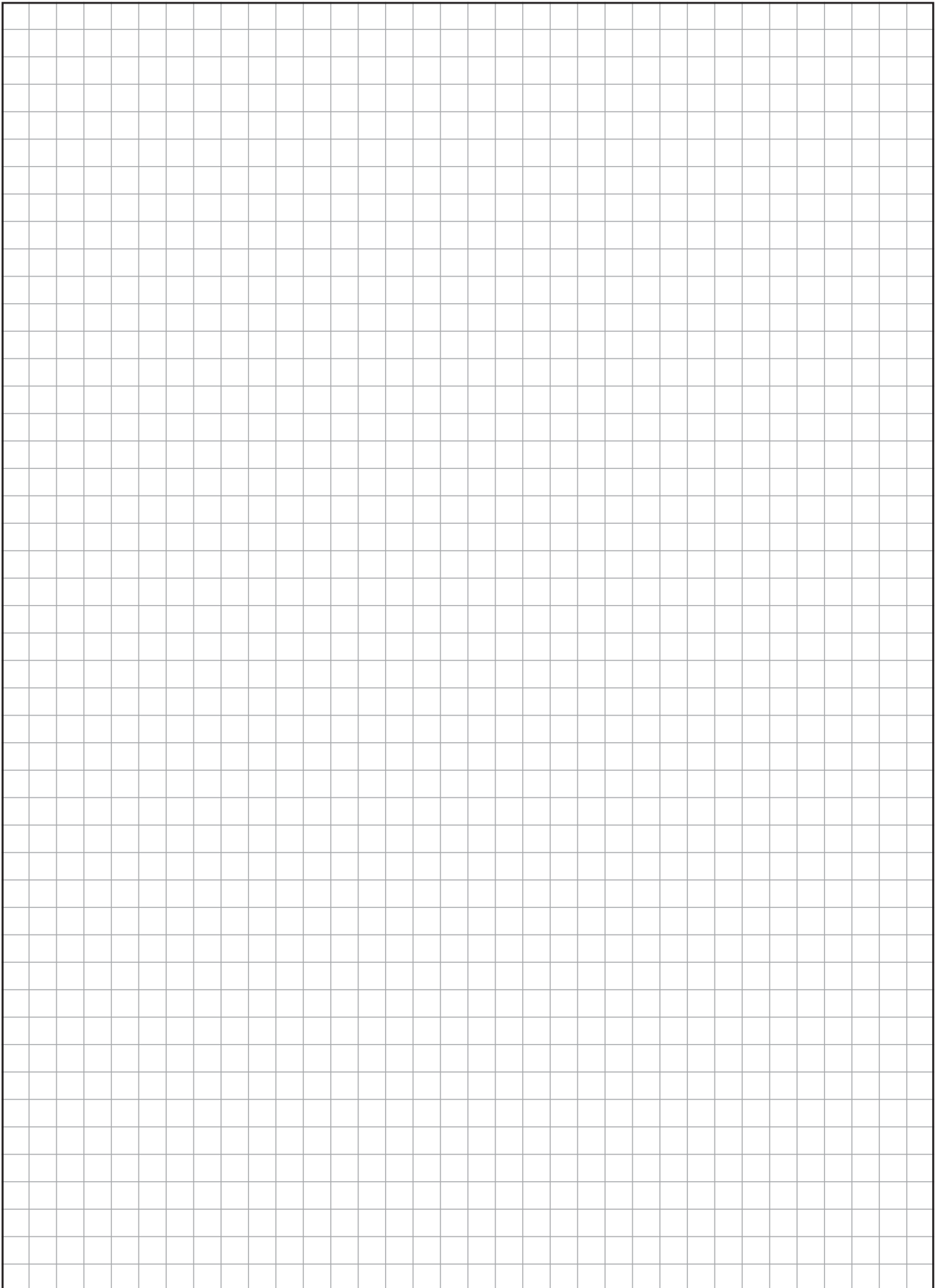

Service passport

Please enter the serial number and the year of manufacture of your machine (see type plate) on the rear side of these operating instructions! Otherwise the service passport will not be valid!

This service passport is a document. Make sure that all the tests and maintenance work carried out on the machine are confirmed by the servicing company here.

<p>Date of test and maintenance work: _____</p> <p>Signature and company stamp</p>	<p>Date of test and maintenance work: _____</p> <p>Signature and company stamp</p>	<p>Date of test and maintenance work: _____</p> <p>Signature and company stamp</p>
<p>Date of test and maintenance work: _____</p> <p>Signature and company stamp</p>	<p>Date of test and maintenance work: _____</p> <p>Signature and company stamp</p>	<p>Date of test and maintenance work: _____</p> <p>Signature and company stamp</p>
<p>Date of test and maintenance work: _____</p> <p>Signature and company stamp</p>	<p>Date of test and maintenance work: _____</p> <p>Signature and company stamp</p>	<p>Date of test and maintenance work: _____</p> <p>Signature and company stamp</p>
<p>Date of test and maintenance work: _____</p> <p>Signature and company stamp</p>	<p>Date of test and maintenance work: _____</p> <p>Signature and company stamp</p>	<p>Date of test and maintenance work: _____</p> <p>Signature and company stamp</p>
<p>Date of test and maintenance work: _____</p> <p>Signature and company stamp</p>	<p>Date of test and maintenance work: _____</p> <p>Signature and company stamp</p>	<p>Date of test and maintenance work: _____</p> <p>Signature and company stamp</p>

EU Declaration of conformity for machines (EU Directive 2006/42/EC)

The manufacturer **Eugen Lägler GmbH, Kappelrain 2, D-74363 Güglingen-Frauenzimmern, Germany**
 Tel.: 0049 - 7135 - 98 90-0 · Fax: 0049 - 7135 - 98 90-98
 E-Mail: info@laegler.com · http://www.laegler.com

certified herewith, that the machine Generic denomination: **Floor sanding machine**
 Function: **Dry sanding of wooden floors**
 Model: **HUMMEL®**
 Serial number: **See type plate**
 Commercial name: **Belt sanding machine**

fulfils all the relevant provisions of the specified above European Directive.

The machine also fulfils all the relevant provisions of the European Directive
Electromagnetic Compatibility (2014/30/EU).

The following harmonized standards have been applied:

DIN EN ISO 12100: Safety of machinery - General principles for design - Risk assessment and risk reduction

DIN EN 60204-1: Safety of machinery - Electrical equipment of machines - Part 1

DIN EN 55014-1: Electromagnetic compatibility - Requirements for household appliances, electric tools and similar apparatus - Part 1

DIN EN 55014-2: Electromagnetic compatibility - Requirements for household appliances, electric tools and similar apparatus - Part 2

DIN EN 61000-3-2: Electromagnetic compatibility (EMC) - Part 3-2: Limits

DIN EN 61000-3-3: Electromagnetic compatibility (EMC) - Part 3-3: Limits

Güglingen-Frauenzimmern, January 1, 2017

Volker Wörner

Volker Wörner, Development Department
 Person Responsible for Documents
 Eugen Lägler GmbH, Kappelrain 2
 D-74363 Güglingen-Frauenzimmern
 Germany

HUMMEL®

Serial number:

Year of manufacture:
